



for a greener tomorrow



**MITSUBISHI
ELECTRIC**

Changes for the Better

FACTORY AUTOMATION

MITSUBISHI ELECTRIC INDUSTRIAL ROBOT MELFA RV-8CRL

e-Factory



MELFA

Slim & Compact Robot Offering a High Level of Utility and Design

Compact and functional design

Slim & compact

A smooth, curved design complements the slim arm and compact joints. The external design is marked by minimalist, functional design.

*Installation pitch: □160 mm (same as RV-4FR and 20% less than RV-7FR)

Protrusionless structure

In addition to a slim, compact exterior and small robot base, its structure features minimal protrusions to the front, back, and sides, resulting in reduced interference with surroundings when the robot operates. This makes it suited to integration with automation cells and manufacturing equipment.



Longest-in-class arm length

Highest-in-class load capacity

Featuring a highest-in-class maximum load capacity of 8 kg, these robots boast a lighter-weight structure and reduced unit weight thanks to their simplified drive system and optimized arm structure, resulting in enhanced load capacity.

Largest-in-class effective working area

Offers highest-in-class maximum reach radius of 931 mm. The use of a no-offset lower arm structure eliminating the J2-axis joint offset minimizes the interference region in the minimum turning radius and provides the largest-in-class effective working area.

Featuring a new motor

Pursuing practical performance

Uses an HK motor, the latest servomotor from Mitsubishi Electric. This allows improved torque characteristics, accuracy, and responsiveness while substantially reducing the size and weight. This adds up to much better robot performance and greater compactness.

Continuous operation performance

Lighter weight and improved heat release translate to improved continuous operation performance.

HK Series



User wiring/piping built into arm

A signal wire and air piping that can be used for gripper control, etc., are built in from the base to the forearm. Both ends of the signal wire have universal D-sub connectors for use in various applications.

Simple structure improves ease of maintenance

Beltless coaxial drive mechanism

A coaxial drive mechanism without belts is used for transmission to each axis (excluding the J4 and J5 axes).

Simplification of the structure has improved transmission efficiency and reliability while also improving the ease of maintenance.

No backup battery

The use of the new HK motor eliminates the need for a battery to back up the robot's internal encoder.

This eliminates the cost and effort of regular replacement as well as the risk of losing origin coordinates due to battery failure.

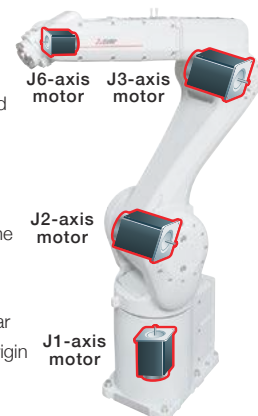

Can be used in oil mist environments

Standard IP65 support

Comes standard with environmental resistance features allowing installation in plants and equipment where dust or oil mist is present.

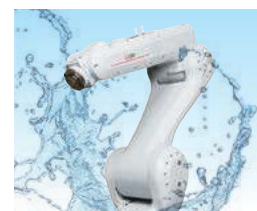

High-performance Controller Makes MELFA More Intelligent

MELFA Smart Plus

Also supports optional MELFA SmartPlus functional enhancement*1

Robot mechanism thermal compensation function

Measures the temperature of the robot arm and automatically corrects errors arising from thermal expansion of the arm.

Calibration assistance function

Automated calibration translates to simplification of installation of two-dimensional vision sensor and improvement of operational accuracy.

Coordinated control of additional axes

Links robot and travel base for high-accuracy processing and assembly at specific speed.

Intelligent technology

Force sensor

- Checks pressing force and force conditions at time of insertion, improving operational quality
- Assembly of difficult-to-fit workpieces
- Teaching support via force information
- Improved force controllability via faster control cycle

Example use of intelligent technology

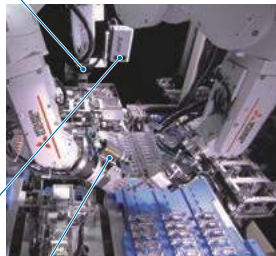

3D vision sensor

- Kitting and separation of scattered or stacked workpieces
- Simplification of installation via support functions

2D vision sensor

- Vision sensor configuration tool allows easy calibration of robot and camera
- Easy connection of robot and camera via Ethernet
- Easy control via robot program vision control command

Software supporting program creation and total engineering: RT ToolBox3

PC software supporting everything from robot system design to installation, debugging, operation, and maintenance

- Program editing and debugging
- Simulation function
- 3D viewer



- Monitoring function
- Melfa RXM.ocx communication middleware

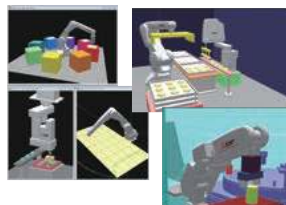

Safety functions

Safety monitoring function

We will prepare a safety function compliant with international standards that simplifies risk assessments.

Safety I/O

Extends redundant safety I/O to 8 inputs and 4 outputs. Enables development of various safety systems.

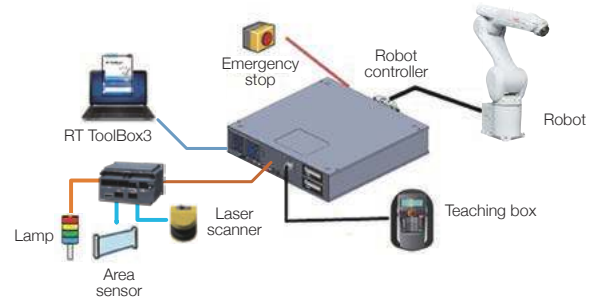

Safety logic editing

Simplifies development and operation of safety systems with safety logic editing.

Tracking and additional axis control

Comes standard with tracking and additional axis control

Tracking

Robot tracks workpiece on conveyor, allowing transfer, alignment, and assembly without stopping conveyor.

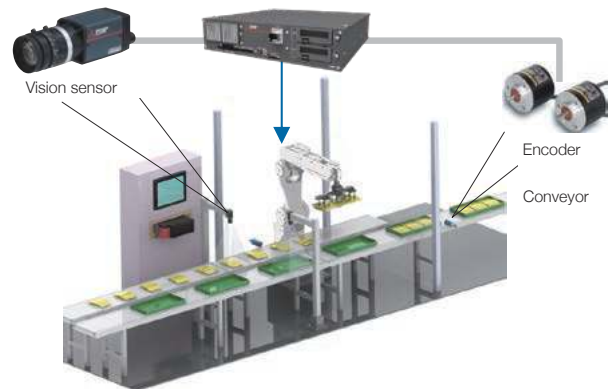

Supports multiple conveyors simultaneously (up to 8)

Additional axis control

Build user mechanism controlling additional axes simultaneously with robot such as robot drive axis or turntable or separate from robot such as loader or positioning device. Control up to 8 axes. Our MELSERVO (MR-J4-B) servomotor can be used with additional axes.

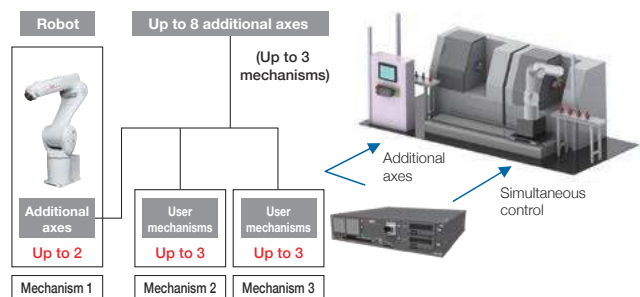

*1: Coming soon

Main Specifications

MELFA

RV-8CRL

Vertical 8kg Type

RV-8CRL



Specifications

Type	Unit	RV-8CRL
Environmental specifications		Oil mist
Protection level		IP65
Installation position		On floor, suspended (wall mounted*)
Structure		Vertical articulated
Freedom of motion		6
Drive system		AC servomotor
Position detection system		Absolute encoder
Load capacity	Rating	kg
	Maximum	kg
Arm length	mm	450+470
Maximum reach radius	mm	931
Installation pitch	mm	□160
Operating range	J1	Degrees
	J2	±170
	J3	±110
	J4	+0 to +165
	J5	±200
	J6	±120
Maximum speed	J1	Degrees/s
	J2	288
	J3	321
	J4	360
	J5	337
	J6	450
Maximum composite speed	mm/sec	10,500
Positional repeat accuracy	mm	±0.02
Ambient temperature	°C	0 to 40
Mass	kg	41
Tolerable moment	J4	Nm
	J5	16.2
	J6	16.2
Tolerable amount of inertia	J4	Kgm2
	J5	0.45
	J6	0.45
Tool wiring		15-pin D-SUB
Tool pneumatic pipes		φ6×2
Machine cable		5 m
Connected controller		CR800-D

External dimensions/operating range

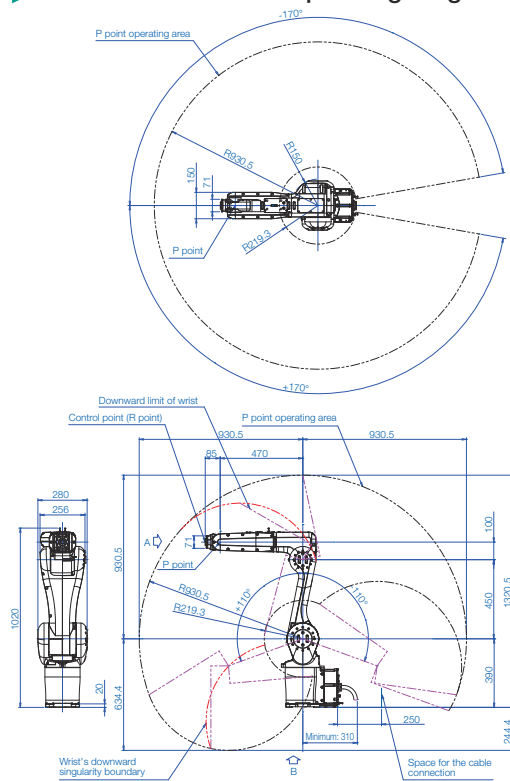

Mechanical interface

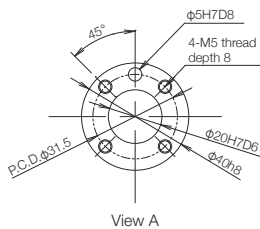

Internal wiring/piping

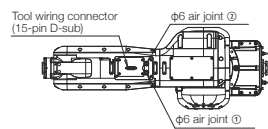

Installation dimensions

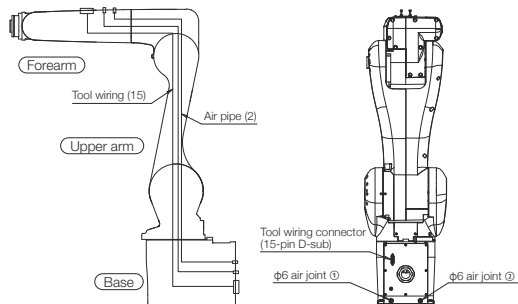
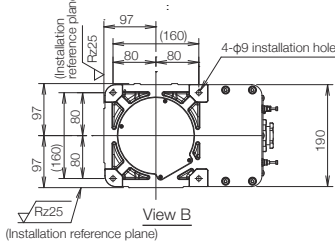

Wiring/piping

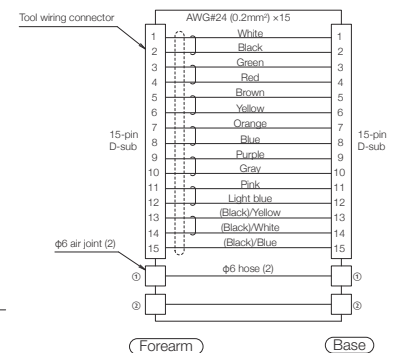

*1: The wall mounting specifications are special specifications that restrict the operating range of the J1 axis.

*2: "Maximum load capacity" is the maximum weight that can be loaded under the limitation of a mechanical interface having a downward attitude (within ±10° of the vertical position).

Controller specifications

MELFA

Controller CR800-D

Stand-alone robot controller
Robot controller can be used for centralized control.



CR800-D

External dimensions

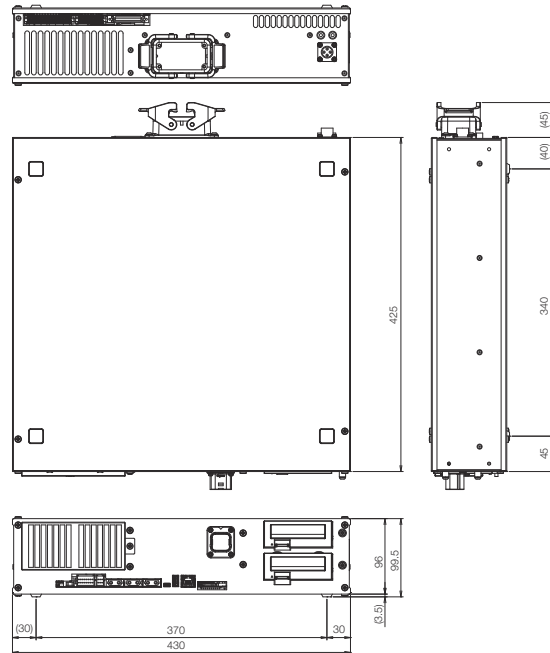

Specifications

Type	Unit	CR800-CVD
Robot CPU		Built into controller
Path control method		PTP control, CP control
Number of axes controlled		Up to 6+8 additional axes
Robot language		MELFA-BASIC V, VI
Position teaching method		Teaching, MDI
Memory capacity	Number of teaching points	points 39000
	Number of steps	step 78000
	Number of programs	unit 512
External input/output	General-purpose I/O	points 32 input/32 output (Up to 256/256 with option) *Shipped with parallel input-output interface (Sink type) installed. Comes with special connectors.
	Dedicated I/O	points Assigned to general-purpose I/O
	Emergency stop input	points 1 (redundant)
	Door switch input	points 1 (redundant)
	Enabling device input *6	points 1 (redundant)
	Emergency stop output	points 1 (redundant)
	Mode output	points 1 (redundant)
	Robot error output	points 1 (redundant)
Synchronization of additional axes	points 1 (redundant)	
Encoder input	channels 2	
Interface	Ethernet	ports 1
	USB *5	ports 1 (10BASE-T/100BASE-TX/1000BASE-T for customer) /Also supports CC-Link IE Field Basic 1 (Ver. 2.0 device function only, miniB terminal)
	Additional-axis interface	channels 1 (SSCNET III/H)
	Extension slot *1	slots 2 *For installing optional interface. Slot 1 equipped with parallel input-output interface (Sink).
Memory extension slot	slots 1	
Ambient temperature	°C	0 to 40
Relative humidity	%RH	45 to 85
Power supply	Input voltage range *2	V Single phase AC200 to 230
	Power capacity *3	KVA 2.0
External dimensions (including legs)	mm	430 (W)×425 (D)×99.5 (H)
Weight	kg	Approx. 12.5
Structure [protective specification]		Self-contained floor type/open structure(Vertical and horizontal position can be placed) [IP20]
Grounding *4	Ω	100 or less (Class D grounding)

*1: For installing optional interface.

*2: Power supply voltage variability is within 10%.

*3: Power capacity is recommended value.

Note that power capacity does not include making current when turning on. Power capacity is an estimate.

*4: Grounding work is to be performed by the customer.

*5: Recommended USB cable (USB Type A, USB Mini-B Type): MR-J3USBCBL3M (Mitsubishi Electric), GT09-C30USB-5P (Mitsubishi Electric System & Service)

*6: Mode select switch is to be provided by the customer.

System configuration

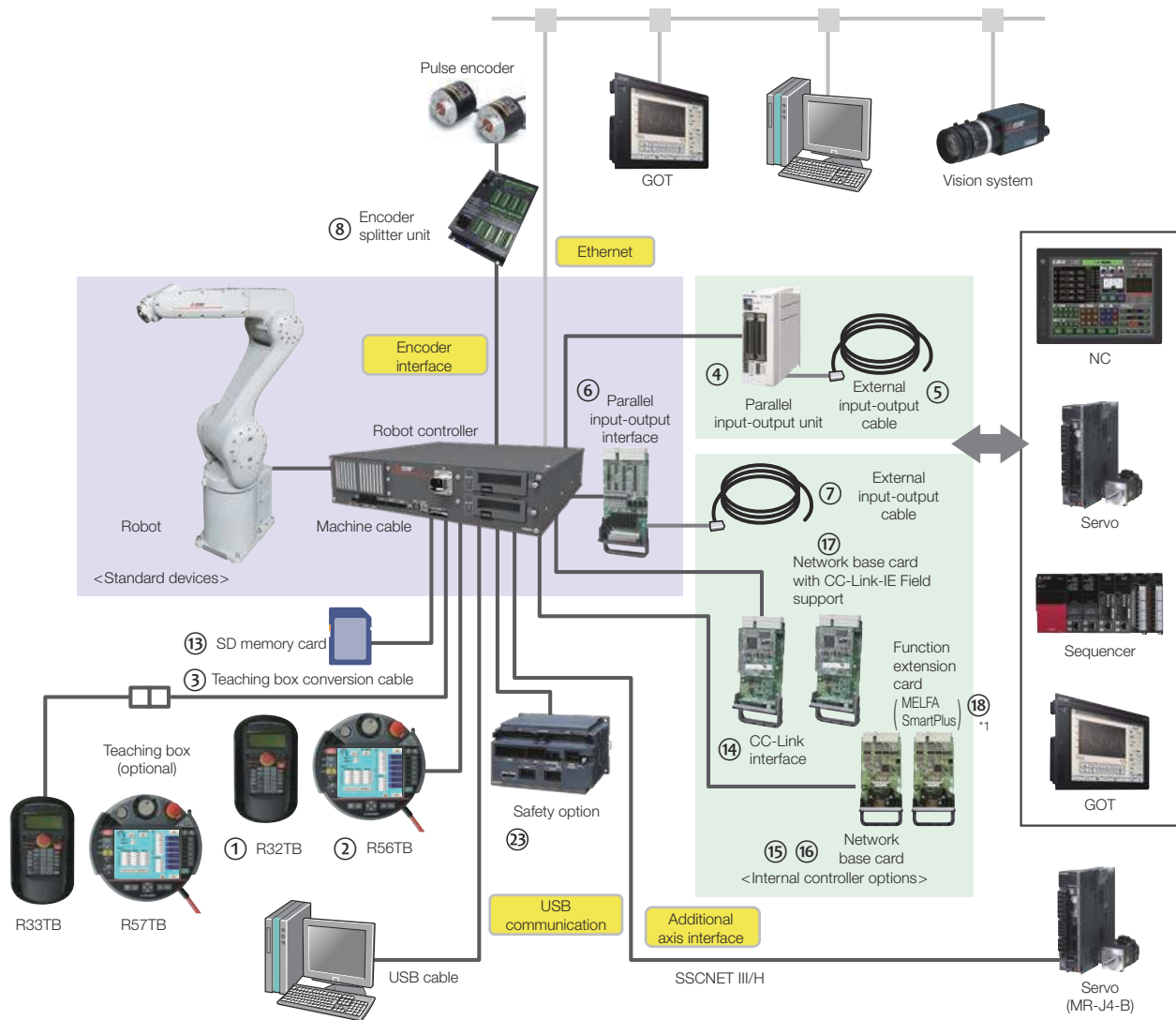

<Software options>

- RT ToolBox3 mini (10)
- RT ToolBox3 (11)
- RT ToolBox3 Pro (12)

<Functional options>

- Force sensor set (21)
- MELFA-3D Vision (22)

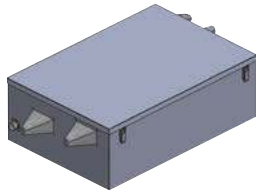

9 Controller protection box

*1: Coming soon

Options

Mechanical options

Name	Model	Specifications
Machine cable (replacement) (Fixed)	1F-□□UCBL-43	Replacement types: 10 m, 15 m, 20 m □□ is cable length (10 m, 15 m, or 20 m)
Machine cable (replacement) (Bending)	1F-□□LUCBL-43	Replacement types: 10 m, 15 m, 20 m □□ is cable length (10 m, 15 m, or 20 m)

Controller options

Number	Name	Model	Specifications
①	Simple teaching box (7 m, 15 m)	R32TB(-□□)	7 m: Standard 15 m: Special (-15 is added to model)
②	High-performance teaching box (7 m, 15 m)	R56TB(-□□)	7 m: Standard 15 m: Special (-15 is added to model)
③	Teaching box conversion cable (33⇒32)	2F-33CON03M	Conversion cable for connecting R32TB/R57TB to CR800 controller. Cable length: 3 m
④	Parallel input-output unit	(Sink type)	2A-RZ361
		(Source type)	2A-RZ371
⑤	External input-output cable (5 m, 15 m)	2A-CBL□□	CBL05: 5 m CBL15: 15 m one end unterminated. For 2A-RZ361/371
⑥	Parallel input-output interface	(Sink type)	2D-TZ368
		(Source type)	2D-TZ378
⑦	External input-output cable (5 m, 15 m)	2D-CBL□□	CBL05: 5 m CBL15: 15 m one end unterminated. For 2D-TZ368/378
⑧	Encoder splitter unit	2F-YZ581	Unit for connecting single rotary encoder to multiple connectors when using tracking function (supports 4 robots)
⑨	Controller protection box	CR800-MB	Built-in controller. Protects against dust and water. (IP54)
⑩	Computer support software mini version	3F-15C-WINJ	Simple (DVD-ROM) (RT ToolBox3 mini)
⑪	Computer support software	3F-14C-WINJ	With simulation function (DVD-ROM) (RT ToolBox3)
⑫	Computer support software Pro version	3F-16D-WINJ	Professional (DVD-ROM) (RT ToolBox3 Pro)
⑬	SD memory card	2F-2GBSD	2GB logging
⑭	CC-Link interface	2D-TZ576	CC-Link intelligent device station Ver2.0 support, 1-4 stations
⑮	Network base card (EtherNet/IP interface)	2D-TZ535	Communication interface for HMS Anybus-CompactCom module. HMS EtherNet/IP module (AB6314) is to be provided by the customer.
⑯	Network base card (PROFINET interface)	2D-TZ535-PN	Communication interface for HMS Anybus-CompactCom module. HMS PROFINETIO module (AB6489-B) is to be provided by the customer.
⑰	Network base card (CC-Link-IE Field interface)	2F-DQ535	Communication interface for HMS Anybus-CompactCom module. HMS CC-Link IE Field module (AB6709) is to be provided by the customer.

Functional options

Number	Name	Model	Specifications	
⑳	Force sensor set	4F-FS002H-W200	Set of equipment required for force control function, including force sensor, interface unit, and support software	
		4F-FS002H-W1000		
㉑	MELFA-3D Vision 2.0	4F-3DVS2-PKG3	Set of equipment required for 3D vision sensor function, including 3D camera unit and control software	
		Additional camera head	4F-3DVS2-OPT3	For enlarged view option
		Enlarged view option	2F-3DVS2-OPT2	Enlarges view about 20-28x
㉒	Safety option	4F-SF002-01	Equipment necessary for safety function	

Expanded software functions

Number	Name	Model	Specifications
㉓	MELFA Smart Plus card pack*1	2F-DQ510	Enables all Type A functions
		2F-DQ520	Enables all Type A and B functions
	MELFA Smart Plus card*1	2F-DQ511	Enables one Type A function of your choice
		2F-DQ521	Enables one Type B function of your choice

Classification	Name	Type	Function outline
Intelligent functions	Calibration assistance function	A	Supports calibration of position with other equipment using 2D vision sensor
	Automatic calibration		Automatically corrects vision sensor coordinates to improve positional accuracy
	Work coordinate calibration		Corrects robot and workpiece coordinates using vision sensor to improve positional accuracy
	Relative position calibration		Correct positions between multiple robots using vision sensor Improve positional accuracy of coordinated actions
Intelligent functions	Robot mechanism thermal compensation function	A	Compensate for thermal expansion of robot arm to improve positional accuracy
	Coordinated control of additional axes	A	Perform high-accuracy coordinated (interpolation) work with additional axes (direct coaxial)
	Preventive maintenance function (Maintenance simulation, wear calculation function)	A	Manage robot condition by tracking operational status
AI functions	MELFA-3D Vision enhancement function	B	Utilizes AI technology to automate 3D vision sensor adjustments and improve measurement and recognition performance
	Enhancement function for force sense control	B	Utilizes AI technology for repeated learning in short time periods and to calculate optimal insertion patterns

*1: Coming soon

Global Partner. Local Friend.

Mitsubishi Electric Corporation Nagoya Works is a factory certified for ISO 14001 (standards for environmental management systems) and ISO 9001 (standards for quality assurance management systems)



MITSUBISHI ELECTRIC CORPORATION

HEAD OFFICE: TOKYO BLDG., 2-7-3 MARUNOUCHI,
CHIYODA-KU, TOKYO 100-8310, JAPAN