



**Mitsubishi Electric Industrial Robot**

**CR800 Series Controller**

**RV-FR Series**

**Standard Specifications Manual**

---

RV-2FR series  
RV-4FR series  
RV-7FR series  
RV-13FR series  
RV-20FR series



## Safety Precautions

Always read the following precautions and the separate "Safety Manual" before starting use of the robot to learn the required measures to be taken.

-  **CAUTION** All teaching work must be carried out by an operator who has received special training. (This also applies to maintenance work with the power source turned ON.)  
Enforcement of safety training
-  **CAUTION** For teaching work, prepare a work plan related to the methods and procedures of operating the robot, and to the measures to be taken when an error occurs or when restarting. Carry out work following this plan. (This also applies to maintenance work with the power source turned ON.)  
Preparation of work plan
-  **WARNING** Prepare a device that allows operation to be stopped immediately during teaching work. (This also applies to maintenance work with the power source turned ON.)  
Setting of emergency stop switch
-  **CAUTION** During teaching work, place a sign indicating that teaching work is in progress on the start switch, etc. (This also applies to maintenance work with the power source turned ON.)  
Indication of teaching work in progress
-  **DANGER** Provide a fence or enclosure during operation to prevent contact of the operator and robot.  
Installation of safety fence
-  **CAUTION** Establish a set signaling method to the related operators for starting work, and follow this method.  
Signaling of operation start
-  **CAUTION** As a principle turn the power OFF during maintenance work. Place a sign indicating that maintenance work is in progress on the start switch, etc.  
Indication of maintenance work in progress
-  **CAUTION** Before starting work, inspect the robot, emergency stop switch and other related devices, etc., and confirm that there are no errors.  
Inspection before starting work

The points of the precautions given in the separate "Safety Manual" are given below. Refer to the actual "Safety Manual" for details.

- ⚠ DANGER** When automatic operation of the robot is performed using multiple control devices (GOT, programmable controller, push-button switch), the interlocking of operation rights of the devices, etc. must be designed by the customer.
- ⚠ CAUTION** Use the robot within the environment given in the specifications. Failure to do so could lead to a drop or reliability or faults. (Temperature, humidity, atmosphere, noise environment, etc.)
- ⚠ CAUTION** Transport the robot with the designated transportation posture. Transporting the robot in a non-designated posture could lead to personal injuries or faults from dropping.
- ⚠ CAUTION** Always use the robot installed on a secure table. Use in an instable posture could lead to positional deviation and vibration.
- ⚠ CAUTION** Wire the cable as far away from noise sources as possible. If placed near a noise source, positional deviation or malfunction could occur.
- ⚠ CAUTION** Do not apply excessive force on the connector or excessively bend the cable. Failure to observe this could lead to contact defects or wire breakage.
- ⚠ CAUTION** Make sure that the workpiece weight, including the hand, does not exceed the rated load or tolerable torque. Exceeding these values could lead to alarms or faults.
- ⚠ WARNING** Securely install the hand and tool, and securely grasp the workpiece. Failure to observe this could lead to personal injuries or damage if the object comes off or flies off during operation.
- ⚠ WARNING** Securely ground the robot and controller. Failure to observe this could lead to malfunctioning by noise or to electric shock accidents.
- ⚠ CAUTION** Indicate the operation state during robot operation. Failure to indicate the state could lead to operators approaching the robot or to incorrect operation.
- ⚠ WARNING** When carrying out teaching work in the robot's movement range, always secure the priority right for the robot control. Failure to observe this could lead to personal injuries or damage if the robot is started with external commands.
- ⚠ CAUTION** Keep the jog speed as low as possible, and always watch the robot. Failure to do so could lead to interference with the workpiece or peripheral devices.
- ⚠ CAUTION** After editing the program, always confirm the operation with step operation before starting automatic operation. Failure to do so could lead to interference with peripheral devices because of programming mistakes, etc.
- ⚠ CAUTION** Make sure that if the safety fence entrance door is opened during automatic operation, the door is locked or that the robot will automatically stop. Failure to do so could lead to personal injuries.
- ⚠ CAUTION** Never carry out modifications based on personal judgments, or use non-designated maintenance parts. Failure to observe this could lead to faults or failures.



 **WARNING**

When the robot arm has to be moved by hand from an external area, do not place hands or fingers in the openings. Failure to observe this could lead to hands or fingers catching depending on the posture.

 **CAUTION**

Do not stop the robot or apply emergency stop by turning the robot controller's main power OFF. If the robot controller main power is turned OFF during automatic operation, the robot accuracy could be adversely affected. Moreover, it may interfere with the peripheral device by drop or move by inertia of the arm.

 **CAUTION**

Do not turn off the main power to the robot controller while rewriting the internal information of the robot controller such as the program or parameters. If the main power to the robot controller is turned off while in automatic operation or rewriting the program or parameters, the internal information of the robot controller may be damaged.

 **DANGER**

Do not connect the Handy GOT when using the GOT direct connection function of this product. Failure to observe this may result in property damage or bodily injury because the Handy GOT can automatically operate the robot regardless of whether the operation rights are enabled or not.

 **DANGER**

Do not connect the Handy GOT to a programmable controller when using an iQ Platform compatible product with the CR800-R/CR800-Q controller. Failure to observe this may result in property damage or bodily injury because the Handy GOT can automatically operate the robot regardless of whether the operation rights are enabled or not.

 **DANGER**

Do not remove the SSCNET III cable while power is supplied to the multiple CPU system or the servo amplifier. Do not look directly at light emitted from the tip of SSCNET III connectors or SSCNET III cables of the Motion CPU or the servo amplifier. Eye discomfort may be felt if exposed to the light. (Reference: SSCNET III employs a Class 1 or equivalent light source as specified in JIS C 6802 and IEC60825-1 (domestic standards in Japan).)

 **DANGER**

Do not remove the SSCNET III cable while power is supplied to the controller. Do not look directly at light emitted from the tip of SSCNET III connectors or SSCNET III cables. Eye discomfort may be felt if exposed to the light. (Reference: SSCNET III employs a Class 1 or equivalent light source as specified in JIS C 6802 and IEC60825-1 (domestic standards in Japan).)

 **DANGER**

Attach the cap to the SSCNET III connector after disconnecting the SSCNET III cable. If the cap is not attached, dirt or dust may adhere to the connector pins, resulting in deterioration connector properties, and leading to malfunction.

 **CAUTION**

Make sure there are no mistakes in the wiring. Connecting differently to the way specified in the manual can result in errors, such as the emergency stop not being released. In order to prevent errors occurring, please be sure to check that all functions (such as the teaching box emergency stop, customer emergency stop, and door switch) are working properly after the wiring setup is completed.

 CAUTION

Use the network equipments (personal computer, USB hub, LAN hub, etc) confirmed by manufacturer. The thing unsuitable for the FA environment (related with conformity, temperature or noise) exists in the equipments connected to USB. When using network equipment, measures against the noise, such as measures against EMI and the addition of the ferrite core, may be necessary. Please fully confirm the operation by customer. Guarantee and maintenance of the equipment on the market (usual office automation equipment) cannot be performed.

 CAUTION

To maintain the safety of the robot system against unauthorized access from external devices via the network, take appropriate measures.  
To maintain the safety against unauthorized access via the Internet, take measures such as installing a firewall.

\*CR800 controller

Notes of the basic component are shown.

**⚠ CAUTION** Please install the earth leakage breaker in the primary side power supply of the controller because of leakage protection.

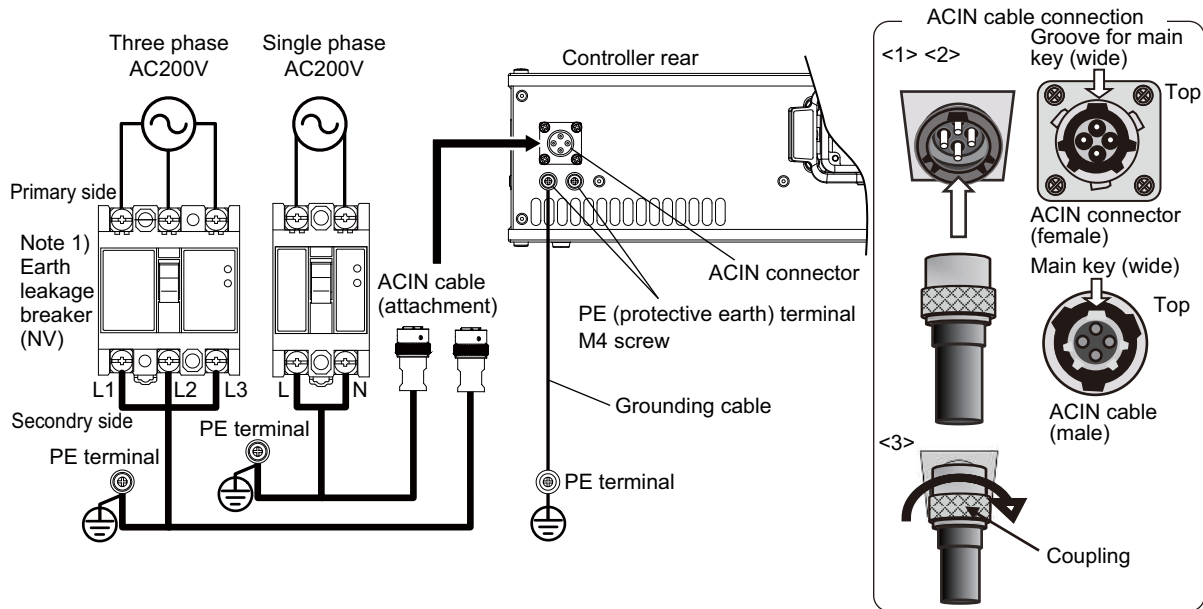

Note 1) Always use the terminal cover for the earth leakage breaker.

1) Prepare the following items.

Part name	Specifications	Remarks
Earth leakage breaker	The following is recommended product. Single phase: NV30FAU-2P-10A-AC100-240V-30mA (Terminal cover: TCS-05FA2) Three phase: NV30FAU-3P-10A-AC100-240V-30mA (Terminal cover: TCS-05FA3)	Prepared by customer.
Cable for primary power supply	AWG14 (2mm <sup>2</sup> ) or above	Prepared by customer. Tightening torque for terminal fixing screw is 2 ~ 3Nm.
Grounding cable	AWG14 (2mm <sup>2</sup> ) or above	Prepared by customer. Tightening torque for terminal fixing screw is 2 ~ 3Nm.
ACIN cable	Terminal: M5, cable length: 3m	Supplied with the product.

- 2) Confirm that the primary power matches the specifications.
- 3) Confirm that the primary power is OFF and that the earth leakage breaker power switch is OFF.
- 4) Connect the ACIN cable to the breaker.  
Connect the power terminals of the ACIN cable to the secondary side terminals of the earth leakage breaker. Also, ground the FG terminal of the cable.
- 5) Connect the ACIN cable to the ACIN connector on the rear of the controller.  
<1> Face the main key on the ACIN cable plug upwards. (Refer to the "ACIN cable connection" illustration.)  
<2> Align the main key of the ACIN cable plug with the grooves on the ACIN connector. Push the plug into the connector as far as it will go.  
The plug may be damaged if it is not correctly aligned with the connector.  
<3> Tighten the coupling on the ACIN cable, turning it to the right until it locks.
- 6) Connect one end of the grounding cable to the PE (protective earth) terminal on the controller and ground the other end (2-point grounding) in order to comply with the requirements of EN 61800-5-1 for the touch current of 3.5 mA AC or more.
- 7) Connect the primary power cable to the primary side terminal of the earth leakage breaker.

■ Revision history

Date of print	Specifications No.	Details of revisions
2017-04-06	BFP-A3470	<ul style="list-style-type: none"> <li>• First print.</li> </ul>
2017-06-29	BFP-A3470-A	<ul style="list-style-type: none"> <li>• The distance to a minimum bendable radius of the machine cable was corrected. (Fig. 2-19, Fig. 2-21)</li> </ul>
2017-11-01	BFP-A3470-B	<ul style="list-style-type: none"> <li>• Description of countermeasures against unauthorized access was added.</li> <li>• Descriptions of CR800-R controller were supplemented.</li> <li>• Correction of errors. GOT1000 was deleted.</li> <li>• Description of optional SD memory card was moved to "3.9.2 CR800-D controller".</li> </ul>
2018-03-01	BFP-A3470-C	<ul style="list-style-type: none"> <li>• Descriptions of CR800-Q controller were added.</li> <li>• Correction of figures. (Fig. 2-25 to 38, 49, and 50)</li> <li>• Correction of errors. (Table 2-4: Secondary piping of RV-7FRL)</li> <li>• Notes were added to section 3.6.</li> <li>• Environmental conditions of electromagnetic noise was modified.</li> </ul>
2018-06-01	BFP-A3470-D	<ul style="list-style-type: none"> <li>• Revised the cycle time of RV-7FRL-SH (0.35 was incorrect)</li> <li>• Listed the representative models for the cycle time (Tables 2-2 to 2-5)</li> </ul>
2018-09-03	BFP-A3470-E	<ul style="list-style-type: none"> <li>• Function extension card (2F-DQ520, 2F-DQ521) were added.</li> <li>• MELFA-3D Vision (4F-3DVS2-PKG3) was added.</li> <li>• MELFA-3D Vision (4F-3DVS2-PKG1) was deleted.</li> </ul>
2018-12-25	BFP-A3470-F	<ul style="list-style-type: none"> <li>• Added further explanation of the ACIN cable.</li> <li>• Added a network base card for EtherCAT (2F-DQ535-EC).</li> <li>• "3.8 Magnet contactor control connector output (AXMC) for addition axes" was modified.</li> </ul>

## ■ Introduction

This series provides compact vertical multi-joint robots for use in machine processes and assemblies. However, to comply with the target application, a work system having a well-balanced robot arm, peripheral devices or robot and hand section must be structured.

When creating these standard specifications, we have edited them so that the Mitsubishi robot's characteristics and specifications can be easily understood by users considering the implementation of robots. However, if there are any unclear points, please contact your nearest Mitsubishi branch or dealer. Mitsubishi hopes that you will consider these standard specifications and use our robots.

Note that in this specification document the specifications related to the robot arm is described [Page 21, "2 Robot arm"](#), the specifications related to the controller [Page 107, "3 Controller"](#), and software functions and a command list [Page 181, "4 Software"](#) separately.

This document has indicated the specification of the following types robot.

Robot type	Series (generic name used in this document for robots listed in each row)
RV-2FR-D/R/Q, RV-2FRL-D/R/Q, RV-2FRB-D/R/Q, RV-2FRBL-D/R/Q	RV-2FR series
RV-4FR-D/R/Q, RV-4FRL-D/R/Q, RV-4FRJL-D/R/Q	RV-4FR series
RV-7FR-D/R/Q, RV-7FRL-D/R/Q	RV-7FR series
RV-7FRLL-D/R/Q, RV-13FR-D/R/Q, RV-13FRL-D/R/Q, RV-20FR-D/R/Q	RV-13FR series

- No part of this manual may be reproduced by any means or in any form, without prior consent from Mitsubishi.
- The contents of this manual are subject to change without notice.
- The specifications values are based on Mitsubishi standard testing methods.
- The information contained in this document has been written to be accurate as much as possible. Please interpret that items not described in this document "cannot be performed." or "alarm may occur".  
Please contact your nearest dealer if you find any doubtful, wrong or skipped point.
- This specifications is original.
- Microsoft, Windows, Windows XP, Windows Vista, Windows 7, Windows 8, Windows 8.1, Windows 10 are either registered trademarks or trademarks of Microsoft Corporation in the United States and/or other countries.
- The official name of Windows® is Microsoft®Windows®Operating System.
- Windows®XP, Windows Vista®, Windows® 7, Windows® 8, Windows® 8.1, Windows® 10 are either product names of Microsoft Corporation in the United States.
- Ethernet is registered trademarks or trademarks of Xerox Corporation in the United States.
- All other company names and production names in this document are the trademarks or registered trademarks of their respective owners.
- Referenced Standard (Requirement of Chinese standardized law): This Product is designed and manufactured accordance with GB 11291.1.

# Contents

	Page
1 General configuration .....	1-1
1.1 Structural equipment .....	1-1
1.1.1 Standard structural equipment .....	1-1
1.1.2 Special specifications .....	1-1
1.1.3 Options .....	1-1
1.1.4 Maintenance parts .....	1-1
1.2 Model type name of robot .....	1-2
1.2.1 How to identify the robot model .....	1-2
(1) RV-2FR series .....	1-2
(2) RV-4FR/7FR/13FR series .....	1-3
1.2.2 Combination of the robot arm and the controller .....	1-4
(1) Stand alone type .....	1-4
(2) MELSEC iQ-R compatible type .....	1-5
(3) MELSEC-Q compatible type .....	1-6
1.2.3 Internal wiring and piping specification types .....	1-7
1.3 Indirect export .....	1-7
1.4 Instruction manuals .....	1-7
1.5 Contents of the structural equipment .....	1-8
1.5.1 Robot arm .....	1-8
(1) RV-2FR series .....	1-8
(2) RV-4FR/7FR/13FR series .....	1-9
1.5.2 Controller .....	1-10
(1) CR800-D controller .....	1-10
(2) CR800-R controller .....	1-11
(3) CR800-Q controller .....	1-13
1.5.3 Function extension device .....	1-15
1.6 Contents of the Option equipment and special specification .....	1-16
1.6.1 List of the robot arm option equipment and special specification .....	1-16
(1) RV-2FR series .....	1-16
(2) RV-4FR/7FR/13FR series .....	1-16
1.6.2 List of the controller option equipment and special specification .....	1-18
1.6.3 Function extension device .....	1-19
2 Robot arm .....	2-21
2.1 Standard specifications .....	2-21
2.1.1 Basic specifications .....	2-21
(1) RV-2FR series .....	2-21
(2) RV-4FR/7FR series .....	2-23
(3) RV-13FR series .....	2-27
2.1.2 The counter-force applied to the installation surface .....	2-30
2.2 Definition of specifications .....	2-31
2.2.1 Pose repeatability .....	2-31
2.2.2 Rated load (mass capacity) .....	2-32
2.2.3 Relationships Among Mass Capacity, Speed, and Acceleration/Deceleration Speed .....	2-35
(1) Setting Load Capacity and Size (Hand Conditions) .....	2-35
2.2.4 Vibrations at the Tip of the Arm during Low-Speed Operation of the Robot .....	2-36
2.2.5 Collision detection .....	2-36
2.2.6 Protection specifications .....	2-37
(1) Types of protection specifications .....	2-37
(2) About the use with the bad environment .....	2-38
2.2.7 Clean specifications .....	2-39
2.3 Names of each part of the robot .....	2-40
2.4 Outside dimensions • Operating range diagram .....	2-41
(1) RV-2FR/2FRB .....	2-41
(2) RV-2FRL/2FRLB .....	2-43
(3) RV-4FR .....	2-45

# Contents

	Page
(4) RV-4FRL/4FRJL .....	2-47
(5) RV-7FR .....	2-49
(6) RV-7FRL .....	2-51
(7) RV-7FRLL .....	2-53
(8) RV-13FR/20FR .....	2-55
(9) RV-13FRL .....	2-57
2.4.1 Outside dimensions of machine cables .....	2-59
2.5 Tooling .....	2-60
2.5.1 Wiring and piping for hand .....	2-60
(1) RV-2FR series .....	2-60
(2) RV-4FR/7FR/13FR series standard specification (with no internal wiring and piping) .....	2-61
(3) RV-4F/7F/13F series internal wiring and piping specification (SH01) .....	2-62
(4) RV-4FR/7FR/13FR series internal wiring and piping specification (SH02) .....	2-63
(5) RV-4FR/7FR/13FR series internal wiring and piping specification (SH03) .....	2-64
(6) RV-4FR/7FR/13FR series internal wiring and piping specification (SH04) .....	2-65
(7) RV-4FR/7FR/13FR series internal wiring and piping specification (SH05) .....	2-66
2.5.2 Internal air piping .....	2-67
(1) RV-2FR series .....	2-67
(2) RV-4FR/7FR/13FR series .....	2-67
2.5.3 Internal wiring for the hand output cable .....	2-67
(1) RV-2FR series .....	2-67
(2) RV-4FR/7FR/13FR series .....	2-67
2.5.4 Internal wiring for the hand input cable .....	2-68
(1) RV-2FR series .....	2-68
(2) RV-4FR/7FR/13FR series .....	2-68
2.5.5 Ethernet cable, option wiring cable .....	2-68
(1) RV-4FR/7FR/13FR series .....	2-68
2.5.6 Wiring and piping system diagram for hand .....	2-69
(1) RV-2FR series .....	2-69
(2) RV-4FR/7FR/13FR series standard specification (with no internal wiring and piping) .....	2-70
(3) RV-4FR/7FR/13FR series internal wiring and piping specification (SH01) .....	2-71
(4) RV-4FR/7FR/13FR series internal wiring and piping specification (SH02) .....	2-72
(5) RV-4FR/7FR/13FR series internal wiring and piping specification (SH03) .....	2-73
(6) RV-4FR/7FR/13FR series internal wiring and piping specification (SH04) .....	2-74
(7) RV-4FR/7FR/13FR series internal wiring and piping specification (SH05) .....	2-75
2.5.7 Electrical specifications of hand input/output .....	2-76
2.5.8 Air supply circuit example for the hand .....	2-77
2.5.9 About the Installation of Tooling Wiring and Piping .....	2-77
2.6 Options .....	2-78
(1) Machine cable (replacement) .....	2-79
(2) Stopper for changing the operating range (RV-2FR series) .....	2-82
(3) J1 axis operating range change (RV-4FR/7FR/13FR series) .....	2-83
(4) Solenoid valve set (RV-2FR series) .....	2-89
(5) Solenoid valve set (RV-4FR/7FR/13FR series) .....	2-91
(6) Hand input cable (RV-2FR series) .....	2-95
(7) Hand input cable (RV-4FR/7FR/13FR series) .....	2-96
(8) Hand output cable (RV-2FR series) .....	2-97
(9) Hand output cable (RV-4FR/7FR/13FR series) .....	2-98
(10) Hand curl tube .....	2-99
(11) Forearm external wiring set/ Base external wiring set (RV-4FR/7FR/13FR series) .....	2-101
2.7 About Overhaul .....	2-105
2.8 Maintenance parts .....	2-106
3 Controller .....	3-107
3.1 Standard specifications .....	3-107
3.1.1 Basic specifications .....	3-107
(1) CR800-D controller .....	3-107

# Contents

	Page
(2) CR800-R controller .....	3-110
(3) CR800-Q controller .....	3-113
3.1.2 Protection specifications and operating supply .....	3-115
(1) Protection specifications .....	3-115
(2) Operating supply .....	3-115
3.2 Names of each part .....	3-116
3.2.1 Controller .....	3-116
3.2.2 Robot CPU unit .....	3-118
(1) CR800-R controller .....	3-118
(2) CR800-Q controller .....	3-119
3.3 Outside dimensions/Installation dimensions .....	3-120
3.3.1 Outside dimensions .....	3-120
(1) Controller .....	3-120
(2) Robot CPU unit .....	3-121
3.3.2 Installation dimensions .....	3-123
(1) Controller .....	3-123
(2) Robot CPU unit .....	3-125
3.4 External input/output .....	3-126
3.4.1 Types .....	3-126
3.5 Dedicated input/output .....	3-127
3.6 Emergency stop input and output etc. ....	3-130
3.6.1 Connection of the external emergency stop and mode selector switch .....	3-130
3.6.2 Special stop input (SKIP) .....	3-134
3.6.3 Door switch function .....	3-135
3.6.4 Mode selector switch function .....	3-135
(1) Automatic Operation/Jog Operation/Brake Release and Necessary Switch Settings .....	3-136
3.7 Additional Axis Function .....	3-137
3.7.1 Wiring of the Additional Axis Interface .....	3-137
3.7.2 Example of the installation of the noise filter .....	3-138
(1) Line noise filter .....	3-140
3.8 Magnet contactor control connector output (AXMC) for addition axes .....	3-141
(1) Example circuit .....	3-141
(2) Image of how to connect the controller connector .....	3-142
3.9 Options .....	3-143
3.9.1 CR800-D/R/Q controller common .....	3-144
(1) Teaching pendant (T/B) .....	3-144
(2) High efficient teaching pendant (T/B) .....	3-147
(3) Function extension card .....	3-149
(4) Controller protection box .....	3-150
(5) MELSOFT RT ToolBox3/MELSOFT RT ToolBox3 mini/MELSOFT RT ToolBox3 Pro .....	3-155
(6) Instruction Manual (bookbinding) .....	3-157
3.9.2 CR800-D controller .....	3-158
(1) Parallel I/O interface .....	3-158
(2) External I/O cable .....	3-163
(3) Parallel I/O unit .....	3-165
(4) External I/O cable .....	3-174
(5) CC-Link interface .....	3-176
(6) SD memory card .....	3-179
3.10 Maintenance parts .....	3-180
4 Software .....	4-181
4.1 List of commands .....	4-181
4.2 List of parameters .....	4-184
5 Instruction Manual .....	5-186
5.1 The details of each instruction manuals .....	5-186



# Contents

	Page
6 Safety .....	6-187
6.1 Safety .....	6-187
6.1.1 Self-diagnosis stop functions .....	6-187
6.1.2 External input/output signals that can be used for safety protection measures .....	6-188
6.1.3 Precautions for using robot .....	6-188
6.1.4 Safety measures for automatic operation .....	6-189
6.1.5 Safety measures for teaching .....	6-189
6.1.6 Safety measures for maintenance and inspections, etc. ....	6-189
6.1.7 Examples of safety measures .....	6-190
(1) External emergency stop connection [supplementary explanation] .....	6-194
6.2 Working environment .....	6-195
6.3 Precautions for handling .....	6-195
7 Appendix .....	Appendix-197
Appendix 1 : Inertia calculation method .....	Appendix-197
Appendix 2 : Safety block diagram .....	Appendix-198
Appendix 3 : Specifications discussion material (RV-2FR series) .....	Appendix-199
Appendix 4 : Specifications discussion material (RV-4FR/7FR series) .....	Appendix-200
Appendix 5 : Specifications discussion material (RV-7FRLL) .....	Appendix-201
Appendix 6 : Specifications discussion material (RV-13FR/13FRL) .....	Appendix-202
Appendix 7 : Specifications discussion material (RV-20FR) .....	Appendix-203

## 1 General configuration

### 1.1 Structural equipment

Structural equipment consists of the following types.

#### 1.1.1 Standard structural equipment

The following items are enclosed as a standard.

No.	Item	Stand alone type	MELSEC iQ-R compatible type	MELSEC-Q compatible type
1	Robot arm	○	○	○
2	Controller	○	○	○
3	Robot CPU unit (MELSEC iQ-R compatible) <sup>Note1)</sup>	-	○	-
	Robot CPU unit (MELSEC-Q compatible) <sup>Note1)</sup>	-	-	○
4	Machine cable	○	○	○
5	Robot arm installation bolts	○	○	○
6	CD-ROM (Instruction manual)	○	○	○

Note1) Including robot CPU unit connecting cable

#### 1.1.2 Special specifications

For the special specifications, some standard configuration equipment and specifications have to be changed before factory shipping. Confirm the delivery date and specify the special specifications at the order.

#### 1.1.3 Options

User can install options after their delivery. The customer needs to arrange for the installation.

#### 1.1.4 Maintenance parts

Materials and parts for the maintenance use.

## 1.2 Model type name of robot

This robot has arranged the type name corresponding to load mass, arm length, and environment specification. Details are shown below, please select the robot suitable for the customer's use.

### 1.2.1 How to identify the robot model

#### (1) RV-2FR series

**RV - 2FR L ▲ - ● -Sxx**

(a) (b) (c) (d) (e)

- (a) RV-2FR .....Indicates the RV-2FR series
- (b) L .....Indicates long arm type.  
Ex)  
Omitted: Standard type  
L: Long arm type
- (c) ▲ .....Indicates the existence of the brake.  
Ex)  
Omitted: J2, J3, and J5 axse have a brake.  
B: All axes have a brake.
- (d) ● .....Indicates the controller type.  
D: Stand alone type  
R: MELSEC iQ-R compatible type  
Q: MELSEC-Q compatible type
- (e) -Sxx .....Indicates a special model. In order, limit special specification.

(2) RV-4FR/7FR/13FR series

**RV** - **◇** **FR** **J** **L** **○** - **●** - **Sxx**  
 (a) (b) (c) (d) (e) (f) (g) (h)

- (a) RV ..... Indicates the vertical multiple-joint robot.
- (b) ◇ ..... Indicates the maximum load.  
 Ex)  
     4 : 4kg  
     7 : 7kg  
    13 : 13kg  
    20 : 20kg
- (c) FR ..... Indicates the FR series.
- (d) J ..... Indicates axis configuration.  
 Ex)  
     Omitted: 6-axis type  
     J: 5-axis type (RV-4FRJL only)
- (e) L ..... Indicates long arm type.  
 Ex)  
     Omitted: Standard type  
     L or LL: Long arm type
- (f) ○ ..... Indicates environment specification.  
 Ex)  
     Omitted: General specifications (IP40)  
     M: Oil mist specifications (IP67)  
     C: Clean specifications (ISO class3)
- (g) ● ..... Indicates the controller type.  
     D: Stand alone type  
     R: MELSEC iQ-R compatible type  
     Q: MELSEC-Q compatible type
- (i) -Sxx ..... Indicates a special model. In order, limit special specification.  
 Ex)  
     -SHxx: Indicates the internal wiring and piping specification.  
     -Sxx: Indicates a special model.

## 1.2.2 Combination of the robot arm and the controller

## (1) Stand alone type

Table 1-1 : Combination of the robot arm and the controller

Robot arm						Controller	
Type name <sup>Note1)</sup>	Protection specification	Arm length <sup>Note2)</sup>	Internal wiring and piping specification (Mechanical I/F)	Brake	Axial constitution		
RV-2FR-D	Standard specification	Standard arm	-	Only J2, J3, J5 axes	6-axis type	CR800-02VD	
RV-2FRL-D		Long arm					
RV-2FRB-D		Standard arm					
RV-2FRLB-D		Long arm					
RV- □ FR-D		Standard arm					
RV-20FR-D		Standard arm					
RV- □ FRL-D		Long arm	equipped <sup>Note3)</sup>	All axes		5-axis type	CR800- □ VD
RV-4FRJL-D		Standard arm					CR800-20VD
RV-7FRLL-D						Long arm	CR800- □ VD
RV- □ FR-D-SH		Standard arm					CR800-20VD
RV-20FR-D-SH						Long arm	CR800- □ VD
RV- □ FRL-D-SH		Standard arm					CR800-20VD
RV-4FRJL-D-SH						Long arm	CR800- □ VD
RV-7FRLL-D-SH		Standard arm					CR800-20VD
RV- □ FRM-D	Long arm					CR800- □ VD	
RV-20FRM-D		Standard arm				CR800-20VD	
RV- □ FRLM-D	Long arm		CR800- □ VD				
RV-4FRJLM-D		Standard arm	CR800-20VD				
RV-7FRLLM-D	Long arm		CR800- □ VD				
RV- □ FRC-D		Clean specification <sup>Note5)</sup>	Standard arm	-		6-axis type	CR800-07VLD
RV-20FRC-D	CR800-20VD						
RV- □ FRLC-D	Long arm		CR800- □ VD				
RV-4FRJLC-D			5-axis type			CR800-04VJD	
RV-7FRLLC-D	6-axis type		CR800-07VLD				

Note1) The " □ " indicates the load mass."4" for 4kg, "7" for 7kg, "13" for 13kg (" □ " of the controller type name is "04", "07", or "13".)

Note2) The RV-4FRJL (5-axis type robot) is long arm type only.

Note3) The types of the internal wiring and piping specification models are shown in [Page 7, "1.2.3 Internal wiring and piping specification types"](#). This robot arm is a shipping special specification model. Check the delivery date.

Note4) This robot arm's protective structure is IP67. The protective structure of all the controllers is IP20 (open type). To protect a controller, use the optional controller protection box (IP54).

Note5) The protective structure of all the controllers is IP20 (open type). To use a controllers in a clean environment, install the controllers to a place that does not violate the cleanliness.

(2) MELSEC iQ-R compatible type

Table 1-2 : Combination of the robot arm and the controller

Robot arm						Controller	
Type name <sup>Note1)</sup>	Protection specification	Arm length <sup>Note2)</sup>	Internal wiring and piping specification (Mechanical I/F)	Brake	Axial constitution		
RV-2FR-R	Standard specification	Standard arm	-	Only J2, J3, J5 axes	6-axis type	CR800-02VR	
RV-2FRL-R		Long arm					
RV-2FRB-R		Standard arm					
RV-2FRLB-R		Long arm					
RV- □ FR-R		Standard arm					
RV-20FR-R		Standard arm					
RV- □ FRL-R		Long arm	equipped <sup>Note3)</sup>	All axes		5-axis type	CR800- □ VR
RV-4FRJL-R		Standard arm					CR800-04VJR
RV-7FRLL-R						Long arm	CR800-07VLR
RV- □ FR-R-SH		Standard arm					CR800- □ VR
RV-20FR-R-SH						Long arm	CR800-20VR
RV- □ FRL-R-SH		Standard arm					CR800- □ VR
RV-4FRJL-R-SH						Long arm	CR800-04VJR
RV-7FRLL-R-SH		Standard arm					CR800-07VLR
RV- □ FRM-R	Long arm					CR800- □ VR	
RV-20FRM-R		Standard arm				CR800-20VR	
RV- □ FRLM-R	Long arm		CR800- □ VR				
RV-4FRJLM-R		Standard arm	CR800-04VJR				
RV-7FRLLM-R	Long arm		CR800-07VLR				
RV- □ FRC-R		Clean specification <sup>Note5)</sup>	Standard arm	--		6-axis type	CR800- □ VR
RV-20FRC-R	CR800-20VR						
RV- □ FRLC-R	Long arm		CR800- □ VR				
RV-4FRJLC-R			5-axis type			CR800-04VJR	
RV-7FRLLC-R	6-axis type		CR800-07VLR				

Note1) The " □ " indicates the load mass."4" for 4kg, "7" for 7kg, "13" for 13kg (" □ " of the controller type name is "04", "07", or "13".)

Note2) The RV-4FRJL (5-axis type robot) is long arm type only.

Note3) The types of the internal wiring and piping specification models are shown in Page 7, "1.2.3 Internal wiring and piping specification types". This robot arm is a shipping special specification model. Check the delivery date.

Note4) This robot arm's protective structure is IP67. The protective structure of all the controllers is IP20 (open type). To protect a controller, use the optional controller protection box (IP54).

Note5) The protective structure of all the controllers is IP20 (open type). To use a controllers in a clean environment, install the controllers to a place that does not violate the cleanliness.

## (3) MELSEC-Q compatible type

Table 1-3 : Combination of the robot arm and the controller

Robot arm						Controller			
Type name <sup>Note1)</sup>	Protection specification	Arm length <sup>Note2)</sup>	Internal wiring and piping specification (Mechanical I/F)	Brake	Axial constitution				
RV-2FR-Q	Standard specification	Standard arm	-	Only J2, J3, J5 axes	6-axis type	CR800-02VQ			
RV-2FRL-Q		Long arm							
RV-2FRB-Q		Standard arm							
RV-2FRLB-Q		Long arm							
RV- □ FR-Q		Standard arm							
RV-20FR-Q		Standard arm							
RV- □ FRL-Q		Long arm	equipped <sup>Note3)</sup>	All axes	All axes	5-axis type	CR800-04VJQ		
RV-4FRJL-Q		Standard arm				6-axis type	CR800-07VLQ		
RV-7FRLL-Q						6-axis type	CR800- □ VQ		
RV- □ FR-Q-SH		Long arm				6-axis type	CR800-20VQ		
RV-20FR-Q-SH						6-axis type	CR800- □ VQ		
RV- □ FRL-Q-SH		Standard arm				5-axis type	CR800-04VJQ		
RV-4FRJL-Q-SH						5-axis type	CR800-07VLQ		
RV-7FRLL-Q-SH		6-axis type				CR800- □ VQ			
RV- □ FRM-Q	Protection specification <sup>Note4)</sup>	Standard arm				-	All axes	6-axis type	CR800-20VQ
RV-20FRM-Q		Long arm						6-axis type	CR800- □ VQ
RV- □ FRLM-Q		Standard arm	5-axis type	CR800-04VJQ					
RV-4FRJLM-Q			5-axis type	CR800-07VLQ					
RV-7FRLLM-Q	Clean specification <sup>Note5)</sup>	Standard arm	-	All axes	6-axis type	CR800- □ VQ			
RV- □ FRC-Q		Long arm			6-axis type	CR800-20VQ			
RV-20FRC-Q					6-axis type	CR800- □ VQ			
RV- □ FRLC-Q		Standard arm			5-axis type	CR800-04VJQ			
RV-4FRJLC-Q					5-axis type	CR800-07VLQ			
RV-7FRLLC-Q		6-axis type			6-axis type	CR800-07VLQ			

Note1) The " □ " indicates the load mass."4" for 4kg, "7" for 7kg, "13" for 13kg (" □ " of the controller type name is "04", "07", or "13".)

Note2) The RV-4FRJL (5-axis type robot) is long arm type only.

Note3) The types of the internal wiring and piping specification models are shown in [Page 7, "1.2.3 Internal wiring and piping specification types"](#). This robot arm is a shipping special specification model. Check the delivery date.

Note4) This robot arm's protective structure is IP67. The protective structure of all the controllers is IP20 (open type). To protect a controller, use the optional controller protection box (IP54).

Note5) The protective structure of all the controllers is IP20 (open type). To use a controllers in a clean environment, install the controllers to a place that does not violate the cleanliness.

### 1.2.3 Internal wiring and piping specification types

The robot arm with in-wrist cables and piping is available. Before the robot arm is shipped from the factory, the tool cables/piping are built into the robot arm's wrist and pulled out from the side of the mechanical interface. This robot arm model eases wiring/piping tasks at the customer's side and improves the reliability against cable disconnections, etc. The following section shows the types. For wiring/piping system diagram for hand of each models, refer to [Page 69, "2.5.6 Wiring and piping system diagram for hand"](#).

(The unlisted robot arms do not have internal cables/pipes. However, they can use the hand input signals and devices such as a visual sensor.)

Table 1-4 : Internal wiring and piping specification types

Special model number <small>Note1)</small>	Piping	Wiring (cable for the connection to each equipment)				Base section external wiring set (corresponding option) <small>Note2)</small>
		Hand input signal	Vision sensor camera	Force sensor unit	Multifunctional electric hand	
-SH01	$\phi 4 \times 4$ <small>Note3)</small>	8 points	Not available			Not available
-SH02	Not available	8 points	1	Either 1		1F-HA01S-01
-SH03	Not available	Not available	1	1	1	1F-HA02S-01
-SH04	$\phi 4 \times 2$	8 points	-	1	-	1F-HA01S-01
-SH05	$\phi 4 \times 2$	8 points	1	-		1F-HA01S-01

Note1) In order to confirm a special model number, see at the end of a type name of a robot.

Note2) The corresponding base external wiring set is attached.

Note3) It can use as a secondary piping of the solenoid-valve set option.

### 1.3 Indirect export

The display in English is available by setting parameter LNG as "ENG."

### 1.4 Instruction manuals

The instruction manuals supplied in CD-ROM.



1.5 Contents of the structural equipment

1.5.1 Robot arm

The list of structural equipment is shown in below.

(1) RV-2FR series

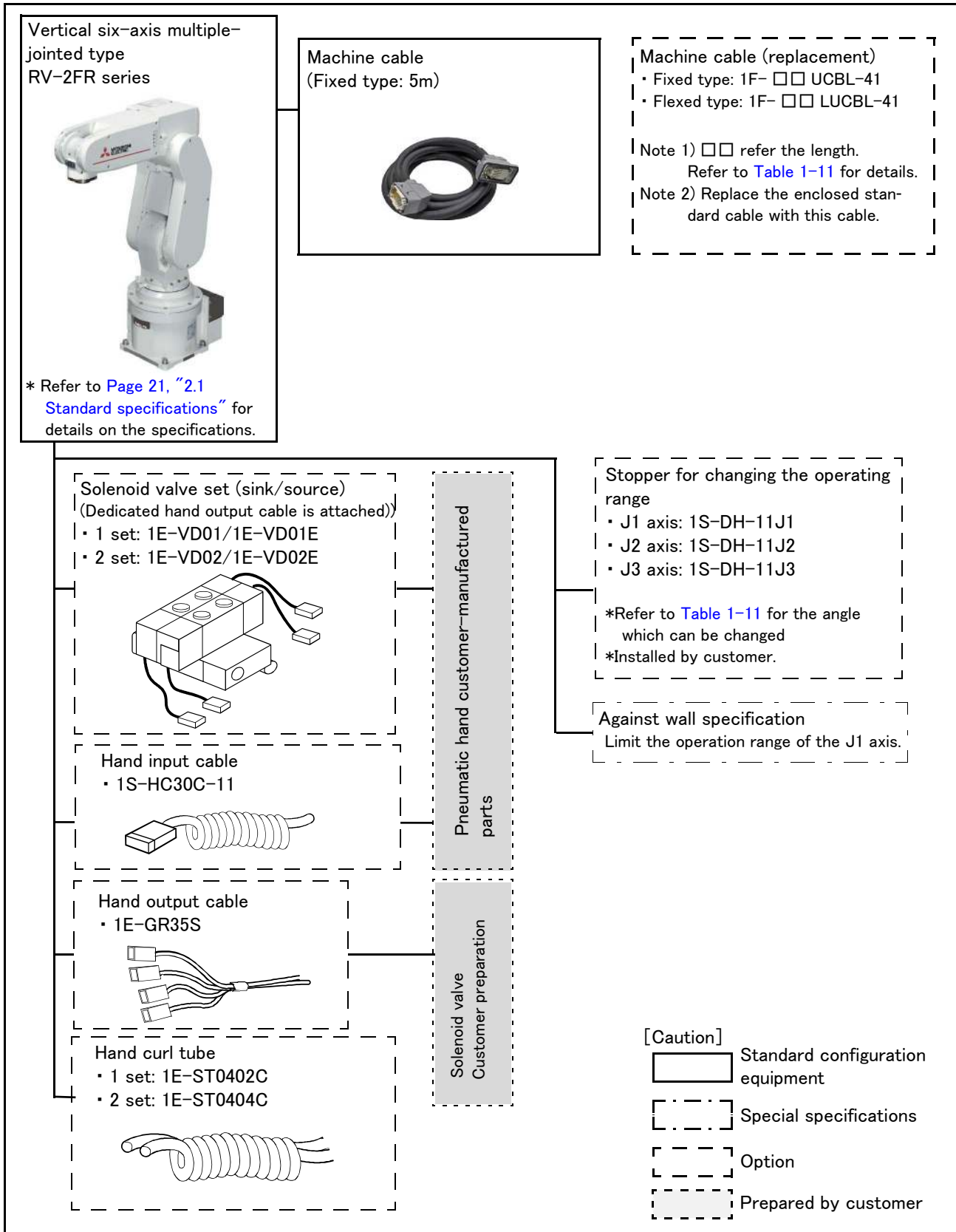

Fig.1-1 : Structural equipment (RV-2FR series)

(2) RV-4FR/7FR/13FR series

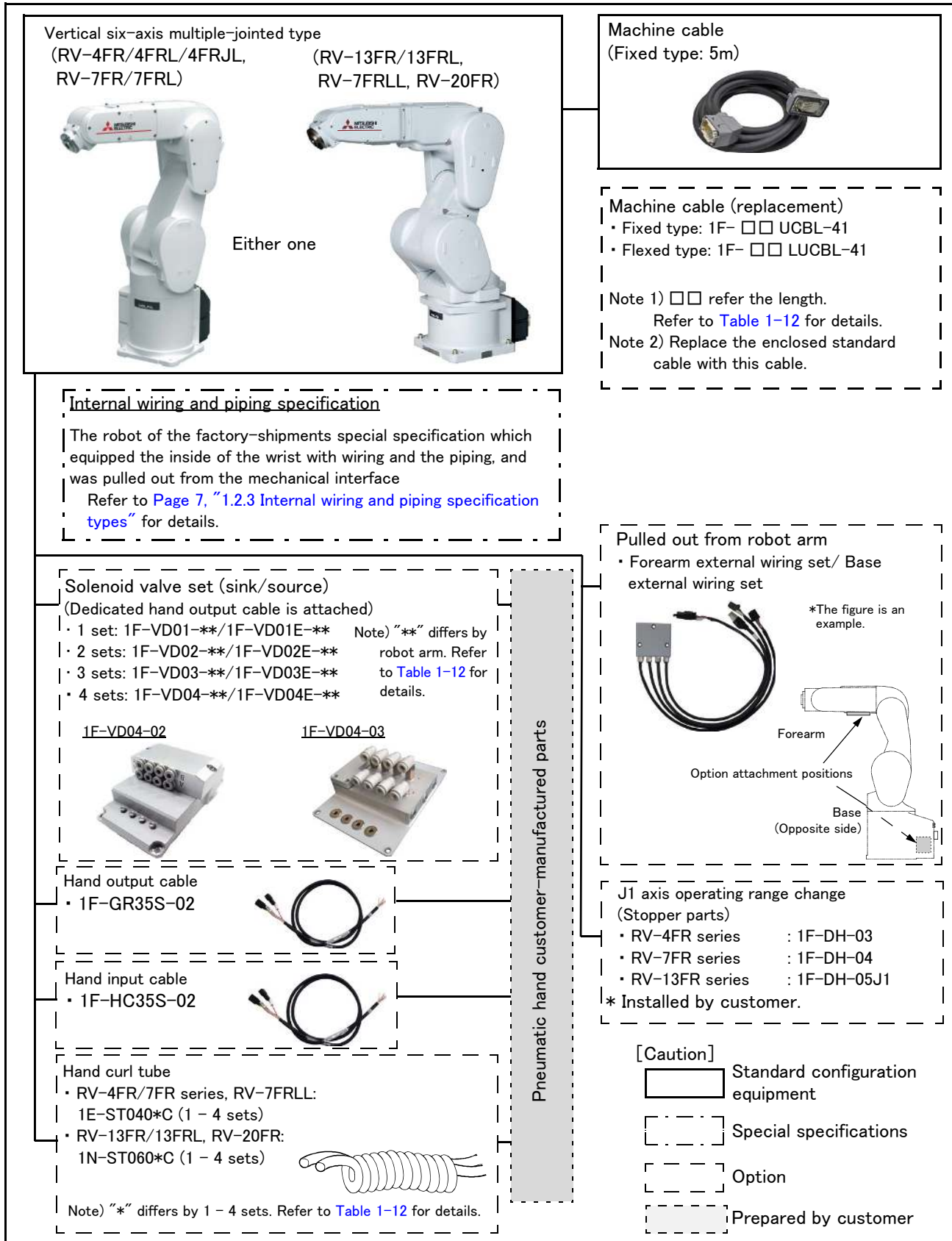

Fig.1-2 : Structural equipment (RV-4FR/7FR/13FR series)

### 1.5.2 Controller

The devices shown below can be installed on the controller.

The controllers that can be connected differ depending on the specification of the robot. (Refer to [Page 2](#), "1.2 Model type name of robot".)

#### (1) CR800-D controller

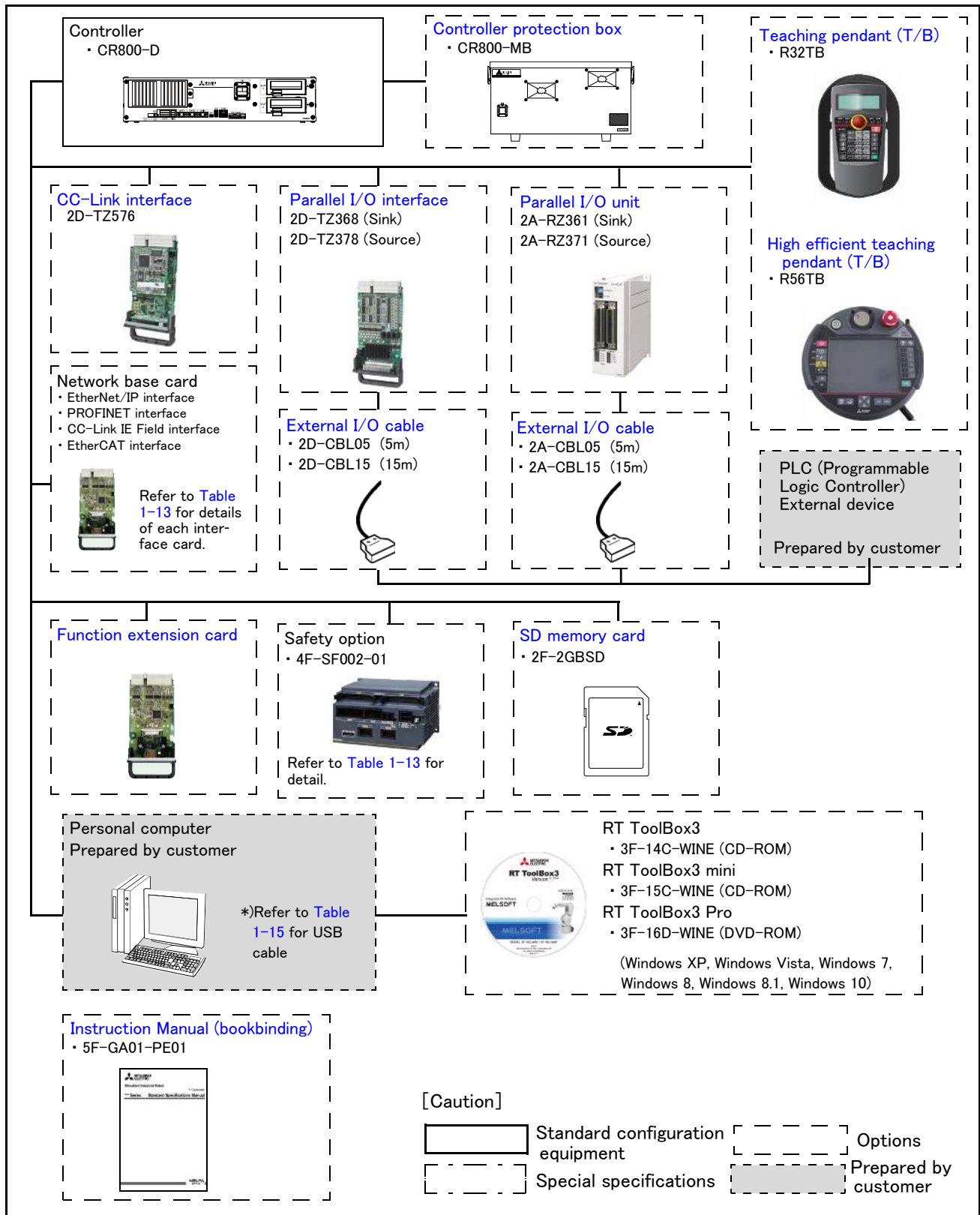

Fig.1-3 : Structural equipment (CR800-D)

(2) CR800-R controller

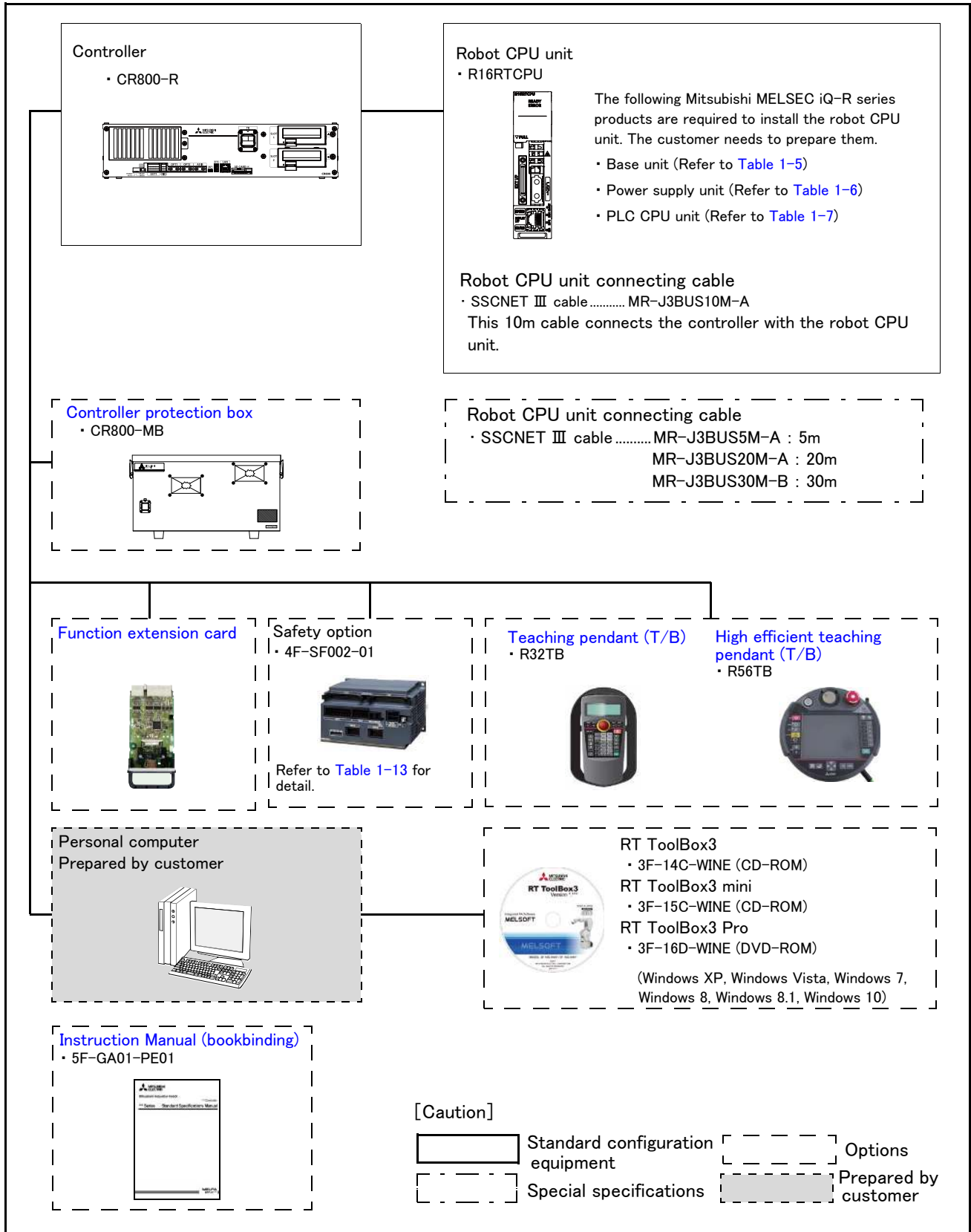

Fig.1-4 : Structural equipment (CR800-R)

Table 1-5 : Base unit

Type name	Remarks
R35B	5 slots: for mounting MELSEC iQ-R series unit
R38B	8 slots: for mounting MELSEC iQ-R series unit
R312B	12 slots: for mounting MELSEC iQ-R series unit

Table 1-6 : Power supply unit

Type name	Remarks
R61P	AC power supply unit. Input: AC100 to 240V, output: DC5V/6.5A
R62P	AC power supply unit. Input: AC100 to 240V, output: DC5V/3.5A, DC24V/0.6A
R63P	DC power supply unit. Input: DC24V, output: DC5V/6.5A
R64P	AC power supply module. Input: AC100 to 240V, output: DC5V/9A

Table 1-7 : PLC CPU unit

Type name	Remarks
R00CPU	Program capacity: 10k steps, Elementary operation processing speed (LD command): 31.36ns
R01CPU	Program capacity: 15k steps, Elementary operation processing speed (LD command): 31.36ns
R02CPU	Program capacity: 20k steps, Elementary operation processing speed (LD command): 3.92ns
R04CPU	Program capacity: 40k steps, Elementary operation processing speed (LD command): 0.98ns
R08CPU	Program capacity: 80k steps, Elementary operation processing speed (LD command): 0.98ns
R16CPU	Program capacity: 160k steps, Elementary operation processing speed (LD command): 0.98ns
R32CPU	Program capacity: 320k steps, Elementary operation processing speed (LD command): 0.98ns
R120CPU	Program capacity: 1200k steps, Elementary operation processing speed (LD command): 0.98ns

(3) CR800-Q controller

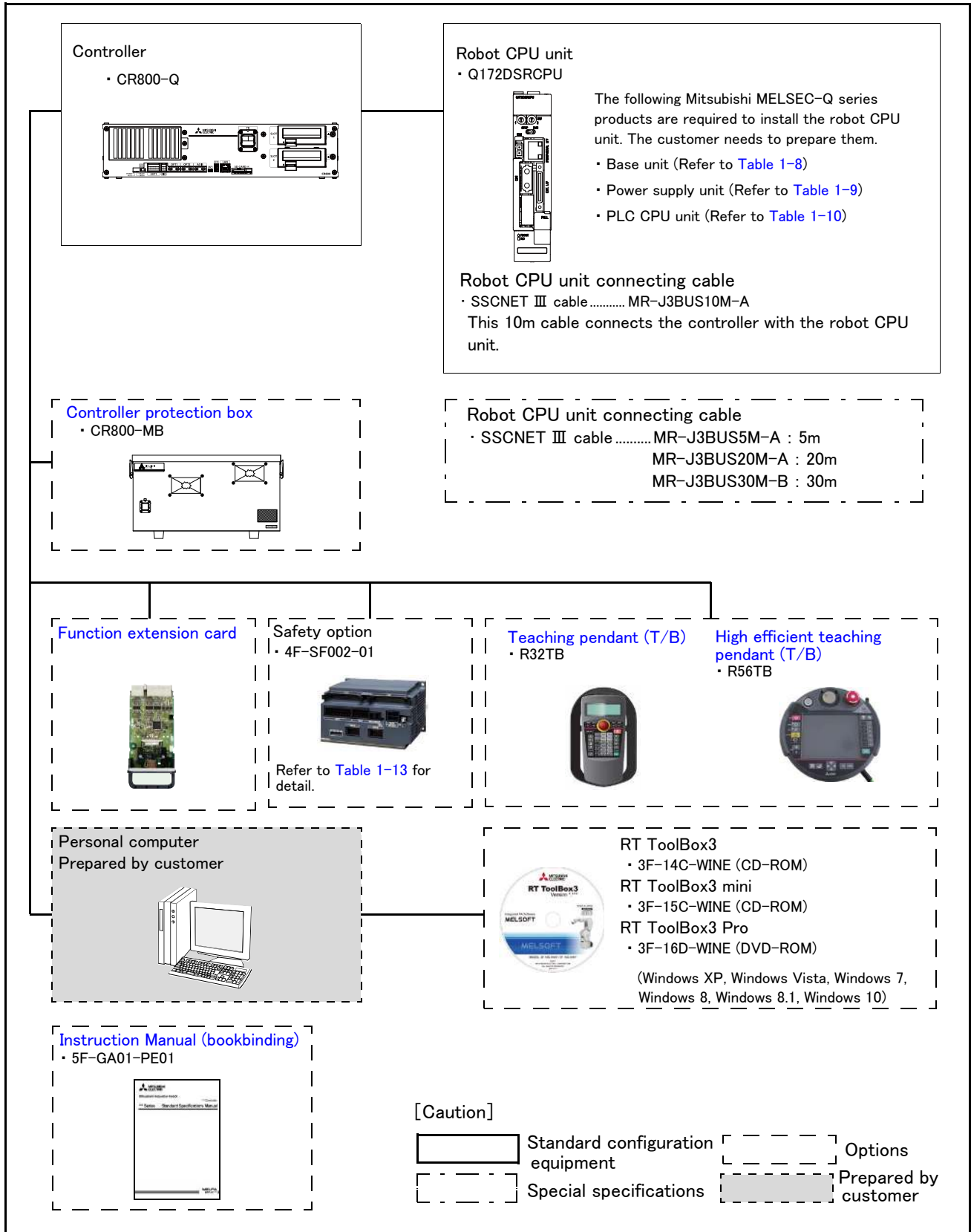

Fig.1-5 : Structural equipment (CR800-Q)

Table 1-8 : Base unit

Type name	Remarks
Q35DB	5 slots: for mounting MELSEC-Q series unit
Q38DB	8 slots: for mounting MELSEC-Q series unit
Q312DB	12 slots: for mounting MELSEC-Q series unit

Table 1-9 : Power supply unit

Type name	Remarks
Q61P	AC power supply unit. Input: AC100 to 240V, output: DC5V/6.5A
Q62P	AC power supply unit. Input: AC100 to 240V, output: DC5V/3A, DC24V/0.6A
Q63P	DC power supply unit. Input: DC24V, output: DC5V/3A, DC5V/6A
Q64PN	AC power supply module. Input: AC100 to 240V/AC200 to 240V, output: DC5V/8.5A

Table 1-10 : PLC CPU unit

Type name	Remarks
Q03UDCPU	Program capacity: 30k steps, Elementary operation processing speed (LD command): 20ns
Q03UDECPU	Program capacity: 30k steps, Elementary operation processing speed (LD command): 20ns
Q04UDHCPU	Program capacity: 40k steps, Elementary operation processing speed (LD command): 9.5ns
Q04UDEHCPU	Program capacity: 40k steps, Elementary operation processing speed (LD command): 9.5ns
Q06UDHCPU	Program capacity: 60k steps, Elementary operation processing speed (LD command): 9.5ns
Q06UDEHCPU	Program capacity: 60k steps, Elementary operation processing speed (LD command): 9.5ns
Q10UDHCPU	Program capacity: 100k steps, Elementary operation processing speed (LD command): 9.5ns
Q10UDEHCPU	Program capacity: 100k steps, Elementary operation processing speed (LD command): 9.5ns
Q13UDHCPU	Program capacity: 130k steps, Elementary operation processing speed (LD command): 9.5ns
Q13UDEHCPU	Program capacity: 130k steps, Elementary operation processing speed (LD command): 9.5ns
Q20UDHCPU	Program capacity: 200k steps, Elementary operation processing speed (LD command): 9.5ns
Q20UDEHCPU	Program capacity: 200k steps, Elementary operation processing speed (LD command): 9.5ns
Q26UDHCPU	Program capacity: 260k steps, Elementary operation processing speed (LD command): 9.5ns
Q26UDEHCPU	Program capacity: 260k steps, Elementary operation processing speed (LD command): 9.5ns
Q50UDEHCPU	Program capacity: 500k steps, Elementary operation processing speed (LD command): 9.5ns
Q100UDEHCPU	Program capacity: 1000k steps, Elementary operation processing speed (LD command): 9.5ns
Q03UDVCPU	Program capacity: 30k steps, Elementary operation processing speed (LD command): 1.9ns
Q04UDVCPU	Program capacity: 40k steps, Elementary operation processing speed (LD command): 1.9ns
Q06UDVCPU	Program capacity: 60k steps, Elementary operation processing speed (LD command): 1.9ns
Q13UDVCPU	Program capacity: 130k steps, Elementary operation processing speed (LD command): 1.9ns
Q26UDVCPU	Program capacity: 260k steps, Elementary operation processing speed (LD command): 1.9ns

### 1.5.3 Function extension device

These devices (option) are used to extend the function of the robot.

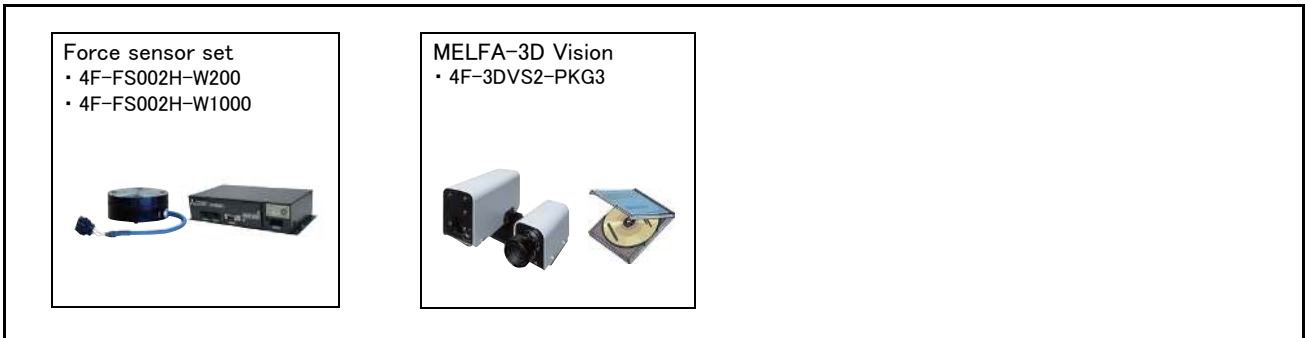

Fig.1-6 : Function extension device



## 1.6 Contents of the Option equipment and special specification

A list of all Optional equipment and special specifications are shown below.

### 1.6.1 List of the robot arm option equipment and special specification

#### (1) RV-2FR series

Table 1-11 : The list of robot option equipment and special specification (RV-2FR series)

Item	Type	Specifications	Classification Note1)	Description
Stopper for changing the operating range	1S-DH-11J1	J1 axis + side: +210, +150, +90 deg. - side: -210, -150, -90 deg. One place selection is possible each for + side / - side. Standard specification is +/-240 deg.	○	This must be installed by the customer.
	1S-DH-11J2	J2 axis + side: +30 deg. - side: -30 deg. One place selection is possible each for + side / - side. Standard specification is +/-120 deg	○	
	1S-DH-11J3	J3 axis + side: +70 deg. - side: Nothing Standard specification is 0 to +160 deg	○	
Machine cable (replacement)	1F- □□ UCBL-41	For fixing	○	" □□ " in type shows the length of the cables as follows. 02=2m, 10=10m, 15=15m, 20=20m
	1F- □□ LUCBL-41	For flexing	○	" □□ " in type shows the length of the cables as follows. 10=10m, 15=15m, 20=20m
Solenoid valve set	1E-VD01/1E-VD01E	1 set (Sink type/Source type)	○	A solenoid valve set for the pneumatic hand
	1E-VD02/1E-VD01E	2 set (Sink type/Source type)	○	
Hand input cable	1S-HC30C-11	Robot side: connector. Hand side: wire.	○	The cable is connected to the sensor by the customer.
Hand output cable	1E-GR35S	Robot side: connector Hand side: wire	○	The cable is connected to the hand output connector by the customer.
Hand curl tube	1E-ST0402C	For solenoid valve 1set: $\phi$ 4x2	○	Curl type air tube
	1E-ST0404C	For solenoid valve 2set: $\phi$ 4x4	○	

Note1) ○ : option, □ : special specifications.

#### (2) RV-4FR/7FR/13FR series

Table 1-12 : The list of the robot arm option equipment and special specification (RV-4FR/7FR/13FR series)

Item	Type	Specifications	Classification Note1)	Description
Internal wiring and piping specification (robot arm)	Special model number -SH01	Functions equipped inside of wrist: Air-hose $\phi$ 4 x 4, Eight hand input signals.	□	<ul style="list-style-type: none"> <li>In order to confirm a special model number, see at the end of a type name of a robot. Example: RV-4FR-D-<b>SH01</b></li> <li>The connection with the force sensor unit uses the attached adapter cable in the force-sensor option. The force-sensor option does not support RV-4FRJL.</li> <li>The corresponding base external wiring set is attached.</li> </ul>
	Special model number -SH02	Functions equipped inside of wrist: Eight hand input signals, connection cable for vision-sensor camera, connection cable for force sensor unit.	□	
	Special model number -SH03	Functions equipped inside of wrist: Connection cable for vision-sensor camera and force sensor unit.	□	
	Special model number -SH04	Functions equipped inside of wrist: Air-hose $\phi$ 4 x 2, Eight hand input signals, connection cable for force sensor unit.	□	
	Special model number -SH05	Functions equipped inside of wrist: Air-hose $\phi$ 4 x 2, Eight hand input signals, connection cable for vision-sensor camera.	□	

## 1 General configuration

Item	Type	Specifications	Classification Note1)	Description
J1 axis operating range change	1F-DH-03	Stopper part for RV-4FR series: Sets as the + side/- side each by the combination within 30, 73, 103 and 146.	○	This must be installed and setting the parameter by the customer. * Refer to Page 83, "(3) J1 axis operating range change (RV-4FR/7FR/13FR series)" for details.
	1F-DH-04	Stopper part for RV-7FR series: Sets as the + side/- side each by the combination within 35, 77, 99 and 141.	○	
	1F-DH-05J1	Stopper part for RV-13FR series: Sets as the + side/- side each by the combination within 30, 73, 103 and 146.	○	
Machine cable (replacement)	1F- □□ UCBL-41	For fixing	○	" □□ " in type shows the length of the cables as follows. 02=2m, 10=10m, 15=15m, 20=20m
	1F- □□ LUCBL-41	For flexing	○	" □□ " in type shows the length of the cables as follows. 10=10m, 15=15m, 20=20m
Solenoid valve set	1F-VD01-02/VD01E-02	1 set (Sink type/Source type)	○	The solenoid-valve set for the hand of the customer setup. Use for RV-4FR/7FR series and RV-7FRL.
	1F-VD02-02/VD02E-02	2 set (Sink type/Source type)	○	
	1F-VD03-02/VD03E-02	3 set (Sink type/Source type)	○	
	1F-VD04-02/VD04E-02	4 set (Sink type/Source type)	○	
	1F-VD01-03/VD01E-03	1 set (Sink type)/(Source type)	○	The solenoid-valve set for the hand of the customer setup. Use for RV-13FR/13FRL and RV-20FR.
	1F-VD02-03/VD02E-03	2 set (Sink type)/(Source type)	○	
	1F-VD03-03/VD03E-03	3 set (Sink type)/(Source type)	○	
	1F-VD04-03/VD04E-03	4 set (Sink type)/(Source type)	○	
Hand input cable	1F-HC35S-02	Robot side: connector. Hand side: wire.	○	The cable is connected to the sensor by the customer.
Hand output cable	1F-GR35S-02	Robot side: connector. Hand side: wire	○	This cable can be used for the solenoid valve prepared by the customer.
Hand curl tube	1E-ST0402C	For solenoid valve 1set.: $\phi$ 4x2	○	Curl type air tube For RV-4FR/7FR series and RV-7FRL.
	1E-ST0404C	For solenoid valve 2set.: $\phi$ 4x4	○	
	1E-ST0406C	For solenoid valve 3set.: $\phi$ 4x6	○	
	1E-ST0408C	For solenoid valve 4set.: $\phi$ 4x8	○	
	1N-ST0602C	For solenoid valve 1set.: $\phi$ 6x2	○	Curl type air tube For RV-13FR/13FRL and RV-20FR.
	1N-ST0604C	For solenoid valve 2set.: $\phi$ 6x4	○	
	1N-ST0606C	For solenoid valve 3set.: $\phi$ 6x6	○	
	1N-ST0608C	For solenoid valve 4set.: $\phi$ 6x8	○	
Forearm external wiring set	1F-HB01S-01	The following cables can be wired outside: hand input signals, multifunctional electric hand/force sensor, and vision sensor.	○	Pulls out from forearm lower part.
	1F-HB02S-01	The following cables can be wired outside: multifunctional electric hand, force sensor, and vision-sensor.	○	
Base external wiring set	1F-HA01S-01	The following cables can be wired outside: multifunctional electric hand/force sensor, and vision-sensor.	○	Pulls out from base side.
	1F-HA02S-01	The following cables can be wired outside: multifunctional electric hand, force sensor, and vision-sensor.	○	

Note1) ○ : option, □ : special specifications.

## 1.6.2 List of the controller option equipment and special specification

Table 1-13 : The list of the controller option equipment and special specification

Item	Type	Specifications	Classification Note1)		Description
			CR800 -D	CR800 -R/Q	
Simple teaching pendant	R32TB	Cable length 7m	○	○	With 3-position enable switch IP65
	R32TB-15	Cable length 15m	○	○	
Highly efficient teaching pendant	R56TB	Cable length 7m	○	○	
	R56TB-15	Cable length 15m	○	○	
Parallel I/O Interface	2D-TZ368(Sink type)/ 2D-TZ378(Source type)	DO: 32 point DI: 32 point Insulated type output signal (0.1A/24V /point) Insulated type input signal (9mA/ 24V /point)	○	-	The card type external input-and-output. Interface. Install to the slot of controller.
External I/O cable (For Parallel I/O Interface)	2D-CBL05	5m	○	-	Use to connect the external peripheral device to the parallel input/output interface.
	2D-CBL15	15m	○	-	
Parallel I/O Unit	2A-RZ361(Sink type)/ 2A-RZ371(Source type)	DO: 32 point/ DI: 32 point Insulated type output signal (0.1A/24V /point) Insulated type input signal (7mA/ 24V /point)	○	-	The unit for expansion the external input/ output. Electrical isolated Type (100mA/Point)
External I/O cable (For Parallel I/O Unit)	2A-CBL05	5m	○	-	Use to connect the external peripheral device to the parallel input/output unit
	2A-CBL15	15m	○	-	
CC-Link interface	2D-TZ576	Only Intelligent device station, Local station	○	-	For MELSEC PLC with CC-Link connec- tion.
Network base card (EtherNet/IP inter- face)	2D-TZ535	Communication interface for mounting the Anybus CompactCom module manufactured by HMS. The customer needs to prepare the EtherNet/IP module (AB6314) manufactured by HMS.	○	-	Refer to separate volume "Network Base Card Instruction Manual" for details.
Network base card (PROFINET inter- face)	2D-TZ535-PN	Communication interface for mounting the Anybus CompactCom module manufactured by HMS. The customer needs to prepare the PROFINET IO module (AB6489-B) manufactured by HMS.	○	-	Refer to separate volume "Network Base Card Instruction Manual" for details.
Network base card (CC-Link IE Field interface)	2F-DQ535	Communication interface for mounting the Anybus CompactCom module manufactured by HMS. The customer needs to prepare the CC-Link IE Field module (AB6709) manufactured by HMS.	○	-	Refer to separate volume "Network Base Card Instruction Manual" for details.
Network base card (EtherCAT interface)	2F-DQ535-EC	Communication interface for mounting the Anybus CompactCom module manufactured by HMS. The customer needs to prepare the EtherCAT module (AB6607) manufactured by HMS.	○	-	Refer to separate volume "Network Base Card Instruction Manual" for details.
Function extension card	2F-DQ510	MELFA Smart Plus card pack (A- type)	○	○	Item to enable the software extension function MELFA Smart Plus.
	2F-DQ520	MELFA Smart Plus card pack (AB- type) Software version of controller: Ver. A3 or later	○	○	
	2F-DQ511	MELFA Smart Plus card (A-type)	○	○	
	2F-DQ521	MELFA Smart Plus card (B-type) Software version of controller: Ver. A3 or later	○	○	
SD memory card	2F-2GBSD	Memory card capacity 2GB.	○	-	

Item	Type	Specifications	Classification Note1)		Description
			CR800 -D	CR800 -R/Q	
Safety option	4F-SF002-01	Item to support the safety I/O.	○	○	Refer to separate volume "Robot Safety Option Instruction Manual" for details.
Controller protection box	C800-MB	IP54	○	○	The controller protection box is used to protect the controller from an oilmist or other operating environment.
RT ToolBox3	3F-14C-WINE	CD-ROM	○	○	Windows XP, Windows Vista, Windows 7, Windows 8, Windows 8.1, Windows 10 Supporting English. (With the simulation function)
RT ToolBox3 mini	3F-15C-WINE	CD-ROM	○	○	Windows XP, Windows Vista, Windows 7, Windows 8, Windows 8.1, Windows 10 Supporting English.
RT ToolBox3 Pro	3F-16D-WINE	DVD-ROM	○	○	Windows XP, Windows Vista, Windows 7, Windows 8, Windows 8.1, Windows 10 Supporting English.
Robot CPU unit connection cable	MR-J3BUS □ M-A	Cable length 5, 20m	-	□	For the servo communication between robot CPU and controller.
	MR-J3BUS30M-B	Cable length 30m	-	□	
Instruction Manual	5F-GA01-PE01	RV-FR series	○	○	

Note1) ○ : option, □ : special specifications.

### 1.6.3 Function extension device

Table 1-14 : The list of function extension device

Item	Type name	Specifications	Classification Note1)		Remarks
			CR800 -D	CR800 -R/Q	
Force sensor set	4F-FS002H-W200	A set of devices necessary for force sense control function, such as a force sensor, an interface unit, and support software.	○	○	Refer to separate volume "Force Sense Function Instruction Manual" for details.
	4F-FS002H-W1000				
MELFA-3D Vision	4F-3DVS2-PKG3	A set of devices necessary for the 3D vision sensor function, such as a 3D camera head.	○	○	Refer to separate volume "MELFA-3D Vision Instruction Manual" for details.
Additional camera head	4F-3DVS2-OPT3	For the optional visual field expander.	○	○	Power cable: separate wire.
Optional visual field expander	2F-3DVS2-OPT2	Visual field expansion of 20 to 28 degrees.	○	○	

Note1) ○ : option.

[Reference]:The recommendation products of the USB cable are shown below

Table 1-15 : Recommendation article of the USB cable

Name	Type name	Supplier	Outside dimensions
USB cable (USB A type-USB mini B type)	GT09-C30USB-5P	mitsubishi electric system & service co., ltd.	Fig. 1-7
	MR-J3USBCBL3M	MITSUBISHI ELECTRIC CO., LTD.	Fig. 1-8

**⚠ Caution**

Be careful to the USB cable to apply neither the static electricity nor the noise. Otherwise, it becomes the cause of malfunction.

**⚠ Caution**

Use the network equipments (personal computer, USB hub, LAN hub, etc) confirmed by manufacturer. The thing unsuitable for the FA environment (related with conformity, temperature or noise) exists in the equipments connected to USB.  
When using network equipment, measures against the noise, such as measures against EMI and the addition of the ferrite core, may be necessary. Please fully confirm the operation by customer. Guarantee and maintenance of the equipment on the market (usual office automation equipment) cannot be performed.

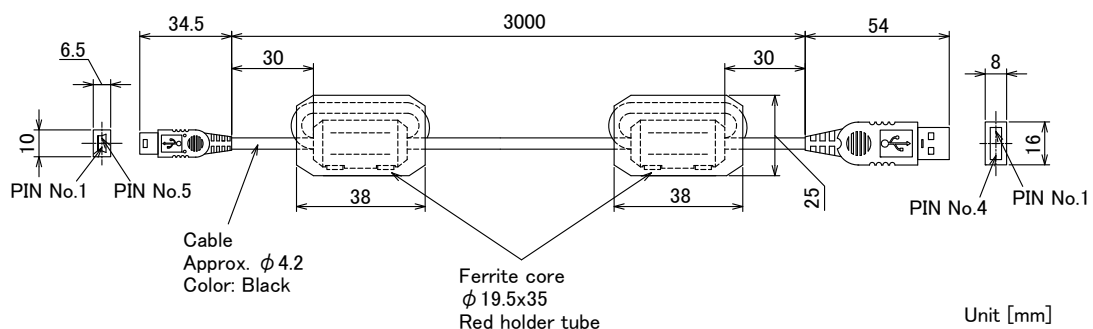

Fig.1-7 : USB cable (GT09-C30USB-5P)

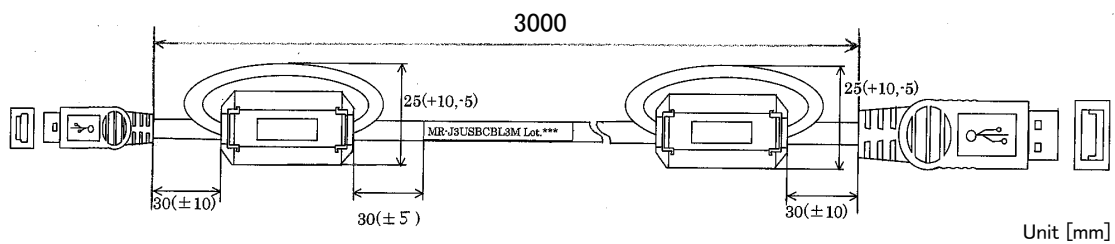

Fig.1-8 : USB cable (MR-J3USBCBL3M)

## 2 Robot arm

### 2.1 Standard specifications

#### 2.1.1 Basic specifications

##### (1) RV-2FR series

Table 2-1 : Standard specifications of robot

Item		Unit	Specifications	
Type			RV-2FR/2FRB <sup>Note1)</sup>	RV-2FRL/2FRLB <sup>Note1)</sup>
Degree of freedom			6	
Installation posture			On floor, hanging (against wall <sup>Note2)</sup> )	
Structure			Vertical, multiple-joint type	
Drive system			AC servo motor (RV-2FR/2FRL: J2, J3, J5 axes have the brake) (RV-2FRB/2FRLB: All axes have the brake)	
Position detection method			Absolute encoder	
Arm length	Upper arm	mm	230	310
	Fore arm		270	335
Operating range	Waist (J1)	Degree	480 (-240 to +240)	
	Shoulder (J2)		240 (-120 to +120)	237 (-117 to +120)
	Elbow (J3)		160 (0 to +160)	
	Wrist twist (J4)		400 (-200 to +200)	
	Wrist pitch (J5)		240 (-120 to +120)	
	Wrist roll (J6)		720 (-360 to +360)	
Speed of motion	Waist (J1)	Degree/ s	300	225
	Shoulder (J2)		150	105
	Elbow (J3)		300	165
	Wrist twist (J4)		450	412
	Wrist pitch (J5)		450	
	Wrist roll (J6)		720	
Maximum resultant velocity <sup>Note3)</sup>		mm/sec	4,950	4,200
Load	Maximum <sup>Note4)</sup>	kg	3.0	
	Rating		2.0	
Pose repeatability <sup>Note5)</sup>		mm	±0.02	
Ambient temperature <sup>Note6)</sup>		°C	0 to 40	
Mass		kg	19	21
Allowable moment load	Wrist twist (J4)	N·m	4.17	
	Wrist pitch (J5)		4.17	
	Wrist roll (J6)		2.45	
Allowable inertia (Maximum) <sup>Note7)</sup>	Wrist twist (J4)	kg·m <sup>2</sup>	0.18 (0.27)	
	Wrist pitch (J5)		0.18 (0.27)	
	Wrist roll (J6)		0.04 (0.1)	
Arm reachable radius front p-axis center point		mm	504	649
Tool wiring			Hand input 4 points/hand output 4 points	
Tool pneumatic pipes			Primary side: φ4 x 4 (Base to fore arm section)	
Supply pressure		MPa	0.5±10%	
Protection specification <sup>Note8)</sup>			IP30 (All axis)	
Degree of cleanliness			—	
Painting color			Light gray (Equivalent to Munsell: 0.6B7.6/0.2, PANTONE: 428C)	

Note1) RV-2FRB/2FRLB is with the brake to all the axes.

Note2) When used by mounting on the wall, a special specification that limits the operating range of the J1 axis will be used. Please give an order separately.

Note3) This is the value on the mechanical interface surface when all axes are combined.

Note4) The maximum load capacity is the mass with the mechanical interface posture facing down word at the ±10° limit.

Note5) The pose repeatability details are given in [Page 31, "2.2.1 Pose repeatability"](#)

- Note6) Sets the robot's operating environmental temperature as parameter OLTMX. Corresponding to the environment, the continuous control action performance and the overload-protection function are optimized. (Refers to "Optimizing the overload level" described in "Chapter 5 Functions set with parameters" of separate instruction manual/ Detailed explanations of functions and operations for details.)
- Note7) The allowable inertia values are the values at the rated load mass. The values in parentheses are the values at the maximum load mass. By controlling the optimum acceleration/deceleration, the allowable inertia (maximum) can be supported.
- Note8) The protection specification details are given in [Page 37](#), "[2.2.6 Protection specifications](#)".

## (2) RV-4FR/7FR series

Table 2-2 : Standard specifications of RV-4FR/7FR series robot (with no internal wiring and piping)

Item		Unit	Specifications				
Type			RV-4FR	RV-4FRL	RV-4FRJL	RV-7FR	RV-7FRL
Environment			Omitted: Standard specification C: Clean specification M: Oil mist specification				
Degree of freedom			6		5	6	
Installation posture			On floor, hanging, (against wall <sup>Note1)</sup> )				
Structure			Vertical, multiple-joint type				
Drive system			AC servo motor (brake provided on all axes)				
Position detection method			Absolute encoder				
Motor capacity	Waist (J1)	W	400			750	
	Shoulder (J2)		400			750	
	Elbow (J3)		100			400	
	Wrist twist (J4)		100	-		100	
	Wrist pitch (J5)		100				
	Wrist roll (J6)		50				
Operating range	Waist (J1)	Degree	±240				
	Shoulder (J2)		±120			-115 to 125	-110 to 130
	Elbow (J3)		0 to 161	0 to 164		0 to 156	0 to 162
	Wrist twist (J4)		±200		-		±200
	Wrist pitch (J5)		±120				
	Wrist roll (J6)		±360				
Speed of motion	Waist (J1)	Degree/s	450	420		360	288
	Shoulder (J2)		450	336		401	321
	Elbow (J3)		300	250		450	360
	Wrist twist (J4)		540		-		337
	Wrist pitch (J5)		623				450
	Wrist roll (J6)		720				
Maximum reach radius (P point)		mm	514.5	648.7		713.4	907.7
Maximum resultant velocity <sup>Note2)</sup>		mm/sec	9,000		8,800	11,000	
Load		kg(N)	4			7	
Pose repeatability <sup>Note3)</sup>		mm	±0.02				
Cycle time <sup>Note4)</sup>		sec	0.36			0.32	0.35
Ambient temperature <sup>Note5)</sup>		°C	0 to 40				
Mass		kg	39	41	39	65	67
Allowable moment load	Wrist twist (J4)	N · m	6.66		-		16.2
	Wrist pitch (J5)		6.66			16.2	
	Wrist roll (J6)		3.90			6.86	
Allowable inertia	Wrist twist (J4)	kg · m <sup>2</sup>	0.20		-		0.45
	Wrist pitch (J5)		0.20			0.45	
	Wrist roll (J6)		0.10				
Tool wiring	Hand input/output		Hand input eight points/hand output eight points				
	LAN cable		Equipped (eight cores) <100BASE-TX>				
	Wiring for user		Equipped (24 cores) <Force sensor etc.>				
Tool pneumatic pipes	Primary piping		φ 6 × 2				
	Secondary piping		φ 4 × 8				
Supply pressure		MPa	0.54				
Protection specification <sup>Note6)</sup>			Standard specification: IP40 Clean specification: ISO class 3 <sup>Note7)</sup> Oil mist specification: IP67 <sup>Note8)</sup> <sup>Note9)</sup>				
Painting color			Light gray (Equivalent to Munsell: 0.6B7.6/0.2, PANTONE: 428C)				

Note1) When used by mounting on the wall, a special specification that limits the operating range of the J1 axis will be used. Please give an order separately.

Note2) This is the value on the mechanical interface surface when all axes are combined.

Note3) The pose repeatability details are given in Page 31, "2.2.1 Pose repeatability"



Note4) The required time period to execute one cycle of the following operation pattern with 1kg load. The cycle time may be longer depending on the required positioning accuracy for the workpiece and the operating position. Cycle time shows the values of RV-4FR-R, RV-4FRL-R, RV-4FRJL-R, RV-7FR-R and RV-7FRL-R.

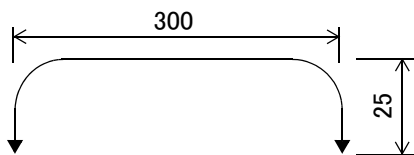

Note5) Sets the robot's operating environmental temperature as parameter OLTMX. Corresponding to the environment, the continuous control action performance and the overload-protection function are optimized. (Refers to "Optimizing the overload level" described in "Chapter 5 Functions set with parameters" of separate instruction manual/ Detailed explanations of functions and operations for details.)

Note6) The protection specification details are given in [Page 37, "2.2.6 Protection specifications"](#).

Note7) The details of the clean specifications are described in [Page 39, "2.2.7 Clean specifications"](#).

Note8) The protection performance cannot be ensured with some oil characteristics. Please contact the dealer.

Note9) If you use the controller in oil mist or similar environments, use the controller protection box to protect the controller from the operation environment. A robot equipped with the controller protection box as standard is available.

Table 2-3 : Standard specifications of RV-4FR/7FR series robot (with internal wiring and piping)

Item		Unit	Specifications				
Type			RV-4FR-SH	RV-4FRL-SH	RV-4FRJL-SH	RV-7FR-SH	RV-7FRL-SH
Environment			Standard specification				
Degree of freedom			6		5	6	
Installation posture			On floor, hanging, (against wall <sup>Note1)</sup> )				
Structure			Vertical, multiple-joint type				
Drive system			AC servo motor (brake provided on all axes)				
Position detection method			Absolute encoder				
Motor capacity	Waist (J1)	W	400			750	
	Shoulder (J2)		400			750	
	Elbow (J3)		100			400	
	Wrist twist (J4)		100	-		100	
	Wrist pitch (J5)		100				
	Wrist roll (J6)		50				
Operating range	Waist (J1)	Degree	±240				
	Shoulder (J2)		±120			-115 ~ 125	-110 ~ 130
	Elbow (J3)		0 to 161	0 to 164		0 to 156	0 to 162
	Wrist twist (J4)		±200		-		±200
	Wrist pitch (J5)		±120				
	Wrist roll (J6)		±200 <sup>Note2)</sup>				
Speed of motion	Waist (J1)	Degree/s	450	420		360	288
	Shoulder (J2)		450	336		401	321
	Elbow (J3)		300	250		450	360
	Wrist twist (J4)		540			337	
	Wrist pitch (J5)		623			450	
	Wrist roll (J6)		720				
Maximum reach radius (P point)		mm	514.5	648.7		713.4	907.7
Maximum resultant velocity <sup>Note3)</sup>		mm/sec	10,000	9,900		12,000	11,700
Load		kg(N)	4			7	
Pose repeatability <sup>Note4)</sup>		mm	±0.02				
Cycle time <sup>Note5)</sup>		sec	0.36			0.32	0.36
Ambient temperature <sup>Note6)</sup>		°C	0 to 40				
Mass		kg	40	42	40	66	68
Allowable moment load	Wrist twist (J4)	N · m	6.66		-		16.2
	Wrist pitch (J5)		6.66			16.2	
	Wrist roll (J6)		3.90			6.86	
Allowable inertia	Wrist twist (J4)	kg · m <sup>2</sup>	0.20		-		0.45
	Wrist pitch (J5)		0.20			0.45	
	Wrist roll (J6)		0.10				
Tool wiring	Hand input/output	Hand input eight points / hand output eight points					
	LAN cable	Equipped (eight cores) <100BASE-TX>					
	Wiring for user	Equipped (24 cores) <Force sensor etc.>					
Tool pneumatic pipes	Primary piping	φ 6 × 2					
	Secondary piping	φ 4 × 4: forearm section φ 4 × 4: passes through in the wrist. <sup>Note7)</sup>					
Supply pressure		MPa	0.54				
Protection specification <sup>Note8)</sup>			Standard specification: IP40				
Painting color			Light gray (Equivalent to Munsell: 0.6B7.6/0.2, PANTONE: 428C)				

Note1) When used by mounting on the wall, a special specification that limits the operating range of the J1 axis will be used. Please give an order separately.

Note2) The operating range of the wrist roll is small compared to the model without internal cables/pipes.

Note3) This is the value on the mechanical interface surface when all axes are combined.

Note4) The pose repeatability details are given in Page 31, "2.2.1 Pose repeatability"

Note5) The required time period to execute one cycle of the following operation pattern with 1kg load. The cycle time may be longer depending on the required positioning accuracy for the workpiece and the operating position. Cycle time shows the values of RV-4FR-R-SH, RV-4FRL-R-SH, RV-4FRJL-R-SH, RV-7FR-R-SH, RV-7FRL-R-SH.

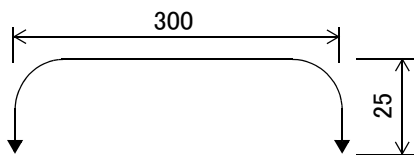

Note6) Sets the robot's operating environmental temperature as parameter OLTMX. Corresponding to the environment, the continuous control action performance and the overload-protection function are optimized. (Refers to "Optimizing the overload level" described in "Chapter 5 Functions set with parameters" of separate instruction manual/ Detailed explanations of functions and operations for details.)

Note7) The internal wiring and piping specification is  $\phi 4 \times 4$ .

Note8) The protection specification details are given in [Page 37](#), "2.2.6 Protection specifications".

## (3) RV-13FR series

Table 2-4 : Standard specifications of RV-13FR series robot (with no internal wiring and piping)

Item		Unit	Specifications			
Type			RV-13FR	RV-13FRL	RV-20FR	RV-7FRL
Environment			Omitted: Standard specification C: Clean specification M: Oil mist specification			
Degree of freedom			6			
Installation posture			On floor, hanging (against wall <sup>Note1)</sup> )			
Structure			Vertical, multiple-joint type			
Drive system			AC servo motor (brake provided on all axes)			
Position detection method			Absolute encoder			
Motor capacity	Waist (J1)	W	1500			
	Shoulder (J2)		1500			
	Elbow (J3)		750			
	Wrist twist (J4)		400			
	Wrist pitch (J5)		200			100
	Wrist roll (J6)		100			50
Operating range	Waist (J1)	Degree	± 190			
	Shoulder (J2)		-90 to +150			
	Elbow (J3)		-10 to +157.5			
	Wrist twist (J4)		± 200			
	Wrist pitch (J5)		± 120			
	Wrist roll (J6)		± 360			
Speed of motion	Waist (J1)	Degree/s	290	234	110	234
	Shoulder (J2)		234	164	110	164
	Elbow (J3)		312	219	110	219
	Wrist twist (J4)		375		124	375
	Wrist pitch (J5)		375		125	450
	Wrist roll (J6)		720		360	720
Maximum reach radius (P point)		mm	1,094	1,388	1,094	1,503
Maximum resultant velocity <sup>Note2)</sup>		mm/sec	10,450	9,700	4,200	15,300
Load Rating (Maximum <sup>Note3)</sup> )		kg	12(13)		15(20)	7(7)
Pose repeatability <sup>Note4)</sup>		mm	± 0.05			± 0.06
Cycle time <sup>Note5)</sup>		sec	0.53	0.68	0.70	0.63
Ambient temperature <sup>Note6)</sup>		°C	0 to 40			
Mass		kg	120	130	120	130
Allowable moment load	Wrist twist (J4)	N · m	19.3		49	16.2
	Wrist pitch (J5)		19.3		49	16.2
	Wrist roll (J6)		11			6.86
Allowable inertia	Wrist twist (J4)	kg · m <sup>2</sup>	0.47		1.4	0.45
	Wrist pitch (J5)		0.47		1.4	0.45
	Wrist roll (J6)		0.14			0.1
Tool wiring	Hand input/output	Hand input eight points / hand output eight points				
	LAN cable	Equipped (eight cores) <100BASE-TX>				
	Wiring for user	Equipped (24 cores) <Force sensor etc.>				
Tool pneumatic pipes	Primary piping	φ 6 × 2				
	Secondary piping	φ 6 × 8			φ 4 × 8	
Supply pressure		MPa	0.54			
Protection specification <sup>Note7)</sup>			Standard specification: IP40 Clean specification: ISO class 3 <sup>Note8)</sup> Oil mist specification: IP67 <sup>Note9)</sup> <sup>Note10)</sup>			IP40
Painting color			Light gray (Equivalent to Munsell: 0.6B7.6/0.2, PANTONE: 428C)			

Note1) When used by mounting on the wall, a special specification that limits the operating range of the J1 axis will be used. Please give an order separately.

Note2) This is the value on the mechanical interface surface when all axes are combined.

Note3) The maximum load means the load which can be carried when the posture of the mechanical interface is restricted downward (less than  $\pm 10\%$  to a vertical direction).

Note4) The pose repeatability details are given in [Page 31, "2.2.1 Pose repeatability"](#)

Note5) The required time period to execute one cycle of the following operation pattern. The cycle time may be longer depending on the required positioning accuracy for the workpiece and the operating position. Cycle time shows the values of RV-13FR-R, RV-13FRL-R, RV-20FR-R, RV-7FRL-R.

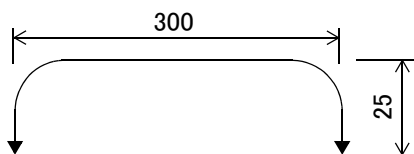

<Conditions>

RV-7FRL: carrying mass of 1kg

RV-13FR(L)/RV-20FR: carrying mass of 5kg

Note6) Sets the robot's operating environmental temperature as parameter OLTMX. Corresponding to the environment, the continuous control action performance and the overload-protection function are optimized. (Refers to "Optimizing the overload level" described in "Chapter 5 Functions set with parameters" of separate instruction manual/ Detailed explanations of functions and operations for details.)

Note7) The protection specification details are given in [Page 37, "2.2.6 Protection specifications"](#).

Note8) The details of the clean specifications are described in [Page 39, "2.2.7 Clean specifications"](#).

Note9) The protection performance cannot be ensured with some oil characteristics. Contact the dealer.

Note10) To use a controller in an oil mist environment, use the optional controller protection box and protect the controller from oil mists.

Table 2-5 : Standard specifications of RV-13FR series robot (with internal wiring and piping)

Item		Unit	Specifications			
Type			RV-13FR-SH	RV-13FRL-SH	RV-20FR-SH	RV-7FRL-SH
Environment			Standard specification			
Degree of freedom			6			
Installation posture			On floor, hanging (against wall <sup>Note1</sup> )			
Structure			Vertical, multiple-joint type			
Drive system			AC servo motor (brake provided on all axes)			
Position detection method			Absolute encoder			
Motor capacity	Waist (J1)	W	1500			
	Shoulder (J2)		1500			
	Elbow (J3)		750			
	Wrist twist (J4)		400			
	Wrist pitch (J5)		200		100	
	Wrist roll (J6)		100		50	
Operating range	Waist (J1)	Degree	±190			
	Shoulder (J2)		-90 to +150			
	Elbow (J3)		-10 to +157.5			
	Wrist twist (J4)		±200			
	Wrist pitch (J5)		±120			
	Wrist roll (J6)		±200 <sup>Note2</sup>			
Speed of motion	Waist (J1)	Degree/s	290	234	110	234
	Shoulder (J2)		234	164	110	164
	Elbow (J3)		312	219	110	219
	Wrist twist (J4)		375		124	375
	Wrist pitch (J5)		375		125	450
	Wrist roll (J6)		720		360	720
Maximum reach radius (P point)		mm	1,094	1,388	1,094	1,503
Maximum resultant velocity <sup>Note3</sup>		mm/sec	10,450	9,700	4,200	15,300
Load Rating (Maximum <sup>Note4</sup> )		kg	12(13)		15(20)	7(7)
Pose repeatability <sup>Note5</sup>		mm	±0.05			±0.06
Cycle time <sup>Note6</sup>		sec	0.53	0.68	0.70	0.63
Ambient temperature <sup>Note7</sup>		°C	0-40			
Mass		kg	120	130	120	130
Allowable moment load	Wrist twist (J4)	N · m	19.3		49	16.2
	Wrist pitch (J5)		19.3		49	16.2
	Wrist roll (J6)		11			6.86
Allowable inertia	Wrist twist (J4)	kg · m <sup>2</sup>	0.47		1.4	0.45
	Wrist pitch (J5)		0.47		1.4	0.45
	Wrist roll (J6)		0.14			0.1
Tool wiring	Hand input/output	Hand input eight points / hand output eight points				
	LAN cable	Equipped (eight cores) <100BASE-TX>				
	Wiring for user	Equipped (24 cores) <Force sensor etc.>				
Tool pneumatic pipes	Promary piping	φ 6 × 2				
	Secondary piping	φ 4 × 4 <sup>Note8</sup>				
Supply pressure		MPa	0.54			
Protection specification <sup>Note9</sup>			Standard specification: IP40			
Painting color			Light gray (Equivalent to Munsell: 0.6B7.6/0.2, PANTONE: 428C)			

Note1) When used by mounting on the wall, a special specification that limits the operating range of the J1 axis will be used. Please give an order separately.

Note2) The operating range of the wrist roll is small compared to the model without internal cables/pipes.

Note3) This is the value on the mechanical interface surface when all axes are combined.

Note4) The maximum load means the load which can be carried when the posture of the mechanical interface is restricted downward (less than ±10% to a vertical direction).

Note5) The pose repeatability details are given in [Page 31, "2.2.1 Pose repeatability"](#)

Note6) The required time period to execute one cycle of the following operation pattern. The cycle time may be longer depending on the required positioning accuracy for the workpiece and the operating position. Cycle time shows the values of RV-13FR-R-SH, RV-13FRL-R-SH, RV-20FR-R-SH, RV-7FRL-R-SH.

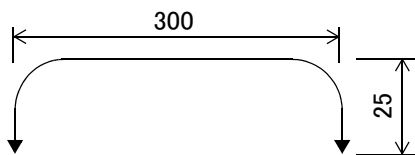

<Conditions>

RV-7FRL: carrying mass of 1kg

RV-13FR(L)/RV-20FR: carrying mass of 5kg

Note7) Sets the robot's operating environmental temperature as parameter OLTMX. Corresponding to the environment, the continuous control action performance and the overload-protection function are optimized. (Refers to "Optimizing the overload level" described in "Chapter 5 Functions set with parameters" of separate instruction manual/ Detailed explanations of functions and operations for details.)

Note8) The internal wiring and piping specification is  $\phi 4 \times 4$ .

Note9) The protection specification details are given in Page 37, "2.2.6 Protection specifications".

### 2.1.2 The counter-force applied to the installation surface

The counter-force applied to the installation surface for the strength design of the robot installation surface is shown.

Table 2-6 : Value of each counter-force

Item	Unit	Value
RV-2FR series		
Falls moment: $M_L$	N · m	240
Torsion moment: $M_T$	N · m	150
Horizontal translation force: $F_H$	N	700
Vertical translation force: $F_V$	N	820
RV-4FR series		
Falls moment: $M_L$	N · m	410
Torsion moment: $M_T$	N · m	400
Horizontal translation force: $F_H$	N	700
Vertical translation force: $F_V$	N	1,200
RV-7FR series		
Falls moment: $M_L$	N · m	900
Torsion moment: $M_T$	N · m	900
Horizontal translation force: $F_H$	N	1,000
Vertical translation force: $F_V$	N	1,700
RV-7FRL, RV-13FR/13FRL, RV-20FR		
Falls moment: $M_L$	N · m	2,060
Torsion moment: $M_T$	N · m	2,060
Horizontal translation force: $F_H$	N	1,750
Vertical translation force: $F_V$	N	2,900

## 2.2 Definition of specifications

The accuracy of pose repeatability mentioned in catalogs and in the specification manual is defined as follows.

### 2.2.1 Pose repeatability

For this robot, the pose repeatability is given in accordance with JIS B 8432 (Pose repeatability). Note that the value is based on 100 measurements (although 30 measurements are required according to JIS).

[Caution] The specified "pose repeatability" is not guaranteed to be satisfied under the following conditions.

- [1] Operation pattern factors
  - 1) When an operation that approaches from different directions and orientations are included in relation to the teaching position during repeated operations
  - 2) When the speed at teaching and the speed at execution are different
- [2] Load fluctuation factor
  - 1) When work is present/absent in repeated operations
- [3] Disturbance factor during operation
  - 1) Even if approaching from the same direction and orientation to the teaching position, when the power is turned OFF or a stop operation is performed halfway
- [4] Temperature factors
  - 1) When the operating environment temperature changes
  - 2) When accuracy is required before and after a warm-up operation
- [5] Factors due to differences in accuracy definition
  - 1) When accuracy is required between a position set by a numeric value in the robot's internal coordinate system and a position within the actual space
  - 2) When accuracy is required between a position generated by the pallet function and a position within the actual space



## 2.2.2 Rated load (mass capacity)

The robot's mass capacity is expressed solely in terms of mass, but even for tools and works of similar mass, eccentric loads will have some restrictions. When designing the tooling or when selecting a robot, consider the following issues.

- (1) The tooling should have the value less or equal than the smaller of the allowable inertia and the allowable moment found in [Page 21, "2.1.1 Basic specifications"](#).

The examples of inertia calculation methods are described in [Page 197, "Appendix 1 : Inertia calculation method"](#).

- (2) [Fig. 2-1](#) to [Fig. 2-5](#) shows the distribution dimensions for the center of gravity in the case where the volume of the load is relatively small. Use this figure as a reference when designing the tooling.
- (3) Even if the load is force, not the mass, design the tooling so that moment does not exceed the allowable moment. Refer to [Page 21, "2.1 Standard specifications"](#) for details of allowable moment value.

[Caution] The mass capacity is greatly influenced by the operating speed of the robot and the motion posture. Even if you are within the allowable range mentioned previously, an overload or generate an overcurrent alarm could occur. In such cases, it will be necessary to change the time setting for acceleration/deceleration, the operating speed, and the motion posture.

[Caution] The overhang amount of the load, such as the mass capacity and the allowable moment of inertia defined in this section, are dynamic limit values determined by the capacity of the motor that drives axes or the capacity of the speed reducer. Therefore, it does not guarantee the accuracy on all areas of tooling. Guaranteed accuracy is measured from the center point of the mechanical interface surface. Please note that if the point of operation is kept away from the mechanical interface surface by long and low-rigid tooling, the positioning accuracy may deteriorate or may cause vibration.

[Caution] Even within the allowable range previously mentioned, an overload alarm may be generated if an ascending operation continues at a micro-low speed. In such a case, it is necessary to increase the ascending speed.

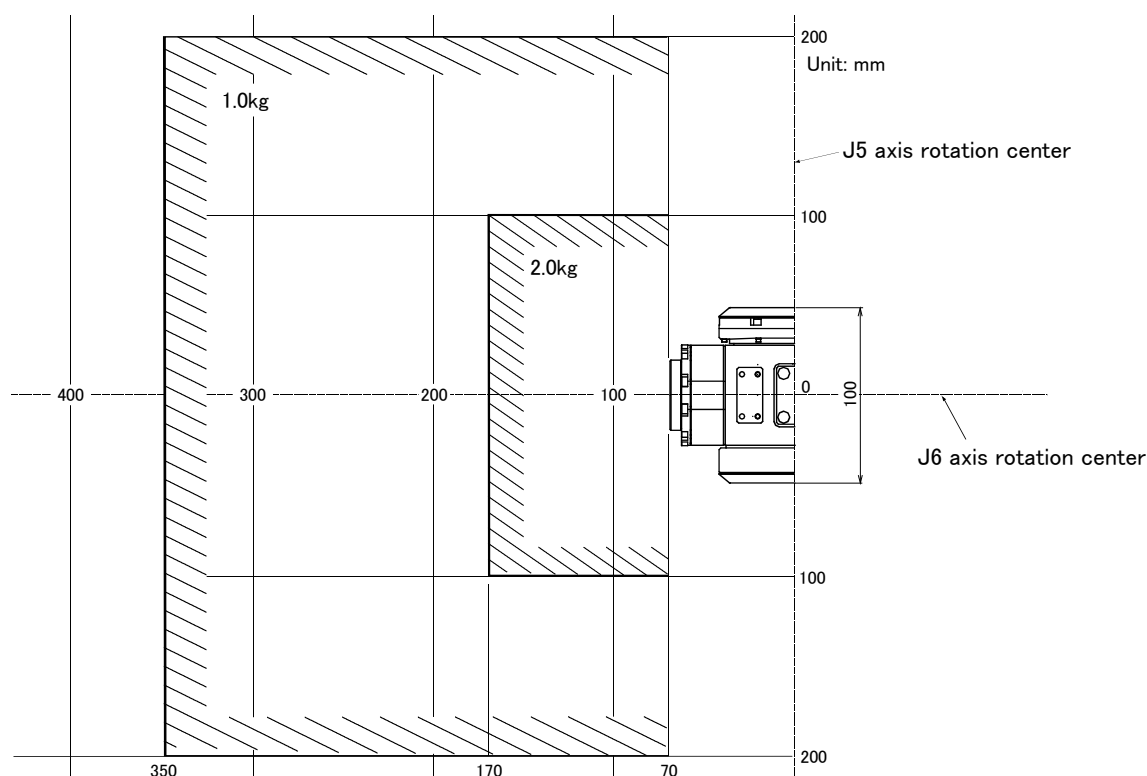

Fig.2-1 : Position of center of gravity for loads (for loads with comparatively small volume): RV-2FR(B)/2FRL(B)

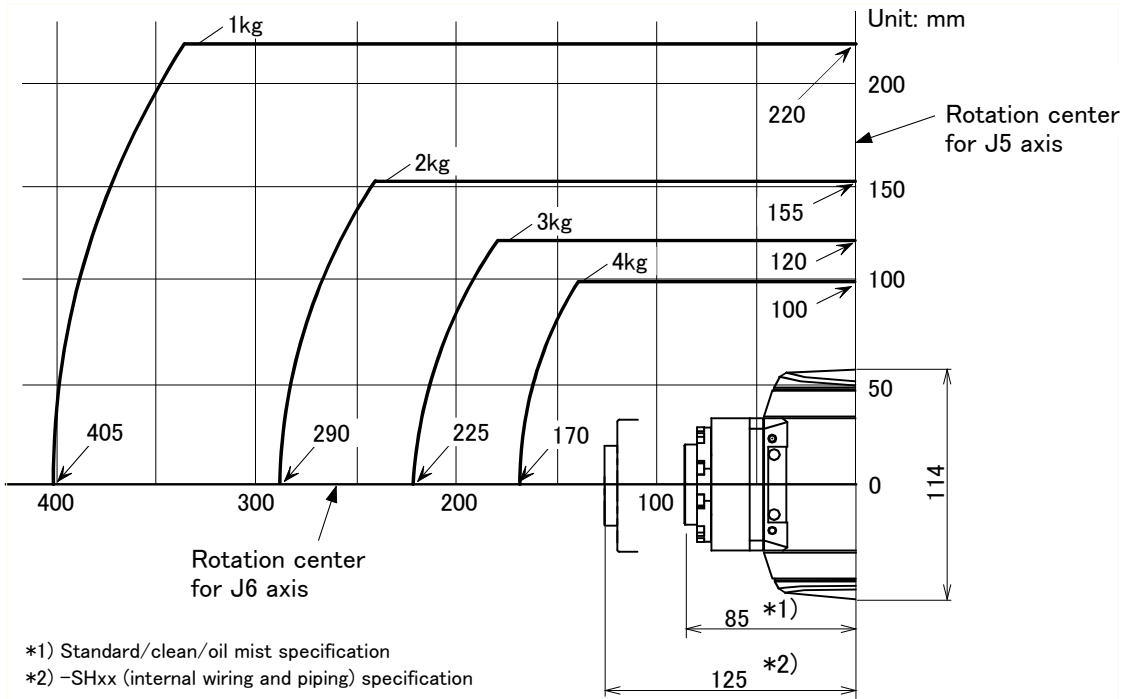

Fig.2-2 : Position of center of gravity for loads (for loads with comparatively small volume): RV-4FR/4FRL/4FRJL

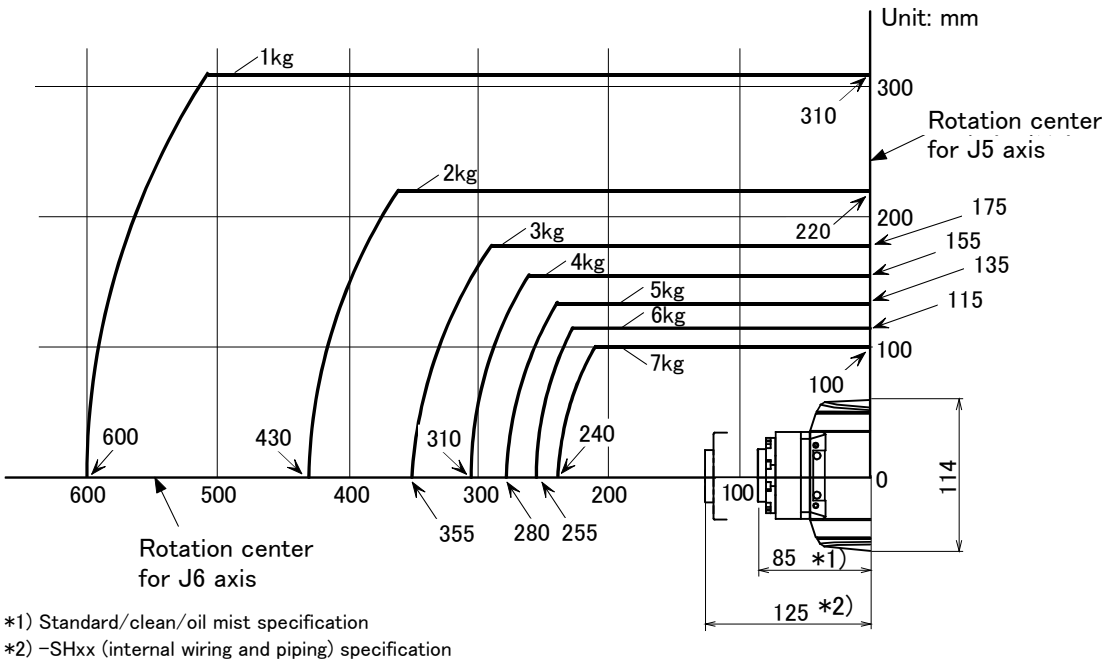

Fig.2-3 : Position of center of gravity for loads (for loads with comparatively small volume): RV-7FR/7FRL/7FRLL

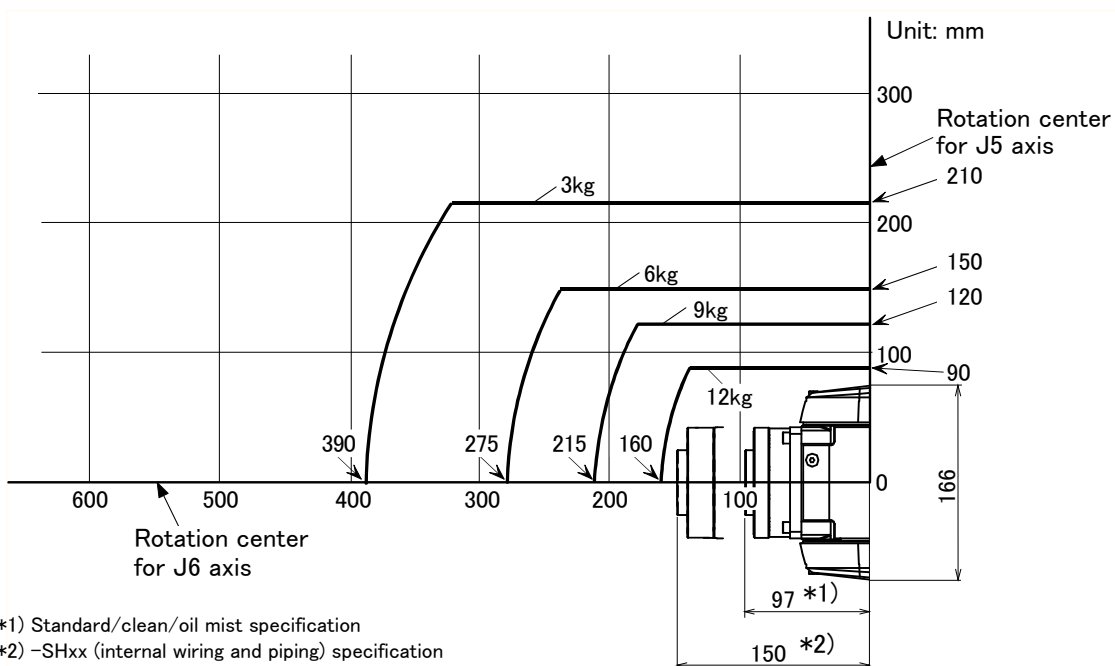

Fig.2-4 : Position of center of gravity for loads (for loads with comparatively small volume): RV-13FR/13FRL

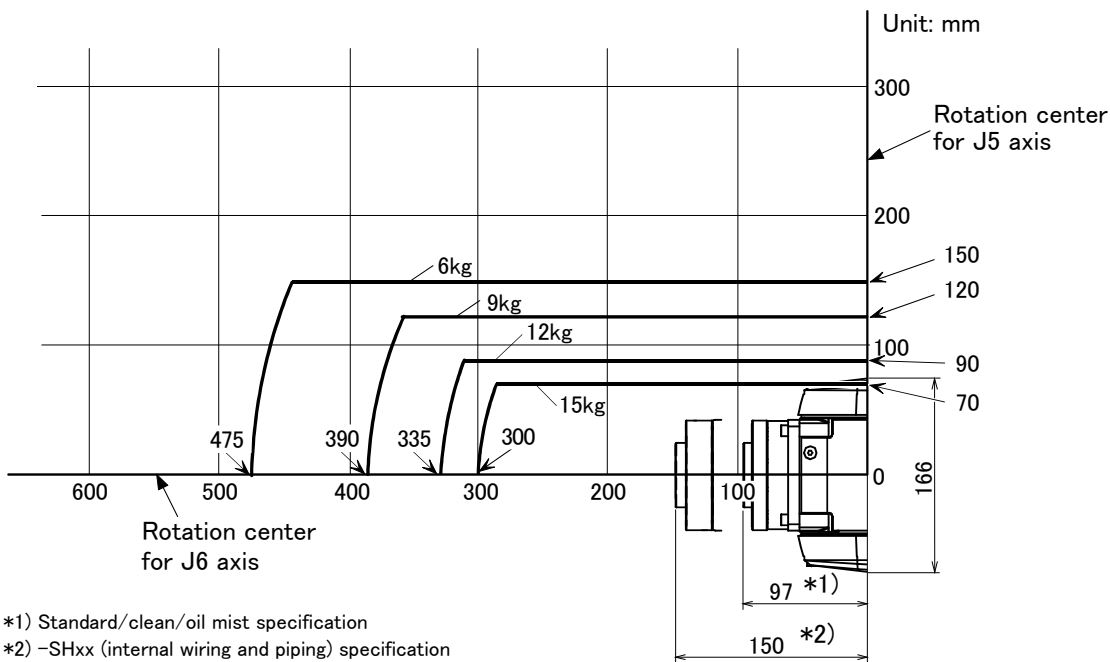

Fig.2-5 : Position of center of gravity for loads (for loads with comparatively small volume): RV-20FR

### 2.2.3 Relationships Among Mass Capacity, Speed, and Acceleration/Deceleration Speed

This robot automatically sets the optimum acceleration and deceleration speeds and maximum speed, according to the load capacity and size that have been set, and operates using these automatically set speeds.

To achieve that, it is necessary to correctly set the actual load data (mass and size of hand and work) to be used. However, vibration, overheating and errors such as excessive margin of error and overload may occur, depending on the robot operation pattern or ambient temperature. In such a case, change the setting value to the +20% range.

If a setting is performed in such a way that it falls below the mounted load, the life span of the mechanism elements used in the robot may be shortened.

#### (1) Setting Load Capacity and Size (Hand Conditions)

Set up the capacity and size of the hand with the "HNDDAT\*" parameter (optimum acceleration/deceleration setting parameter), and set up the capacity and size of the work with the "WRKDAT\*" parameter. Numbers 0 to 8 can be used for the asterisk (\*) part. Designate the "HNDDAT\*" and "WRKDAT\*" parameters to be used using the "LoadSet" command in a program.

For more details, refer to the separate "Instruction Manual/Detailed Explanation of Functions and Operations." It is the same meaning as "LoadSet 0.0" if not using the "LoadSet".

##### <Factory default settings of RV-2FR series>

	Hand mass	Size X	Size Y	Size Z	Center-of-gravity position X	Center-of-gravity position Y	Center-of-gravity position Z
	[kg]	[mm]	[mm]	[mm]	[mm]	[mm]	[mm]
HNDDAT* =	3.0	200.0	200.0	150.0	0.0	0.0	100.0
WRKDAT* =	0.0	0.0	0.0	0.0	0.0	0.0	0.0

##### <Factory default settings of RV-4FR series>

	Hand mass	Size X	Size Y	Size Z	Center-of-gravity position X	Center-of-gravity position Y	Center-of-gravity position Z
	[kg]	[mm]	[mm]	[mm]	[mm]	[mm]	[mm]
HNDDAT* =	4.0	78.0	78.0	90.0	0.0	0.0	85.0 <sup>Note1)</sup>
WRKDAT* =	0.0	0.0	0.0	0.0	0.0	0.0	0.0

Note1) -SHxx (internal wiring and piping) specification is 45.0 [mm].

##### <Factory default settings of RV-7FR series, RV-7FRLL>

	Hand mass	Size X	Size Y	Size Z	Center-of-gravity position X	Center-of-gravity position Y	Center-of-gravity position Z
	[kg]	[mm]	[mm]	[mm]	[mm]	[mm]	[mm]
HNDDAT* =	7.0	95.0	95.0	95.0	0.0	0.0	155.0 <sup>Note1)</sup>
WRKDAT* =	0.0	0.0	0.0	0.0	0.0	0.0	0.0

Note1) -SHxx (internal wiring and piping) specification is 115.0 [mm].

##### <Factory default settings of RV-13FR/13FRL>

	Hand mass	Size X	Size Y	Size Z	Center-of-gravity position X	Center-of-gravity position Y	Center-of-gravity position Z
	[kg]	[mm]	[mm]	[mm]	[mm]	[mm]	[mm]
HNDDAT* =	13.0	120.0	120.0	117.0	0.0	0.0	100.0 <sup>Note1)</sup>
WRKDAT* =	0.0	0.0	0.0	0.0	0.0	0.0	0.0

Note1) -SHxx (internal wiring and piping) specification is 47.0 [mm].

##### <Factory default settings of RV-20FR>

	Hand mass	Size X	Size Y	Size Z	Center-of-gravity position X	Center-of-gravity position Y	Center-of-gravity position Z
	[kg]	[mm]	[mm]	[mm]	[mm]	[mm]	[mm]
HNDDAT* =	20.0	160.0	160.0	100.0	0.0	0.0	168.0 <sup>Note1)</sup>
WRKDAT* =	0.0	0.0	0.0	0.0	0.0	0.0	0.0

Note1) -SHxx (internal wiring and piping) specification is 115.0 [mm].

### 2.2.4 Vibrations at the Tip of the Arm during Low-Speed Operation of the Robot

Vibrations at the tip of the arm may increase substantially during the low-speed operation of the robot, depending on the combination of robot operation, hand mass and hand inertia. This problem occurs when the vibration count specific to the robot arm and the vibration count of the arm driving force are coming close to each other. These vibrations at the tip of the arm can be reduced by taking the following measures:

- 1) Lower the robot's operating speed by approximately 5% from high speed using the OvrD command.
- 2) Change and move the teaching points of the robot.
- 3) Change the hand mass and hand inertia.

### 2.2.5 Collision detection

This series have the "collision detection function" which detects the abnormalities by the collision of the robot arm, however initial setting is in invalid condition.

The enable/disable of this function can be changed by parameter: COL and command: ColChk, this function is effective for protect of the robot and of the peripheral equipment.

The abnormalities are detected by the robot's kinetics model, presuming torque necessary for movement at any time. Therefore, the setting parameter (HNDDAT\*, WRKDAT\*) of the hand and the work piece conditions should be right. And, it may be detected as the collision in movement as speed and motor torque are changed rapidly. (for example, the movement near the place of the origin by linear interpolation, the reversal movement, the cold condition, the operation after long term stoppage)

In such a case, by adjusting the value of the setting parameter (COLLVL, COLLVLJG) of the collision detection level according to actual use environment, the sensitivity of collision detection can be optimized and the damage risk can be reduced further. And, in the operation after the low temperature or long term stoppage, please operate by accustoming at low speed (warm-up), or use the warm-up operation mode.

Refer to the separate instruction manual "Detailed explanations of functions and operations" for details of related parameter.

Table 2-7 : Factory-shipments condition

	JOG operation	Automatic
RV-2FR/4FR/7FR/13FR series	Invalid	Invalid

## 2.2.6 Protection specifications

### (1) Types of protection specifications

The robot arm has protection specifications that comply with the IEC Standards. The protection specifications and applicable fields are shown in [Table 2-8](#).

Table 2-8 : Protection specifications and applicable fields

Type	Protection specifications (IEC Standards value)	Classification	Applicable field	Remarks
RV-2FR/2FRL/2FRB/2FRLB	IP30	General environment specifications	General assembly Slightly dusty environment	
RV-4FR/4FRL/4FRJL RV-7FR/7FRL RV-7FRLL RV-13FR/13FRL RV-20FR	IP40			
RV-4FRM/4FRML/4FRJLM RV-7FRM/7FRML RV-7FRLLM RV-13FRM/13FRML RV-20FRM	IP67	Oil mist specifications	Machine tool (cutting) Machine shop with heavy oil mist Dusty work shop	Note that if the cutting machine is using abrasive materials, the robot's life will be shortened.



## CAUTION

Use the controller protection box to protect the controller from the environment when the controller will be used in the environment such as the oil mist shown in the [Table 2-8](#).

The IEC IP symbols define the degree of protection against solids and fluids, and do not indicate a protective structure against the entry of oil.

The IEC standard is described by the following "Information" And, the corrosion of the rust etc. may occur to the robot with the liquids.

#### 【Information】

- The IEC IP30

The protection standard for approach in the dangerous spot in the tool. It indicates the protective structure that the proximity probe 2.5mm in diameter must not advance.

- The IEC IP40

The protection standard for approach in the dangerous spot in the tool. It indicates the protective structure that the proximity probe 2.5mm in diameter must not advance.

- The IEC IP67

Protection against water infiltration as specified in IP67 indicates a protective structure that is not harmfully affected, even if the test device dives underwater for the 30 minutes. The diving depth is shown below. When the height of the test device is less than 850 mm, the position of the lowest part is 1 m from the water surface.

When the height of the test device is 850 mm or more, the position of the highest part is 150 mm from the water surface.

## (2) About the use with the bad environment

The robot arm with protection specification (oil mist specification) is made by order. This robot has protection methods that conform to IEC's IP67 standards (splashproof type).

Usage conditions are shown below.

- 1) The robot is designed for use in combination with machining device.
- 2) To ensure IP67 over the warranty period and further, the inside of the robot arm needs to be pressurized. Use the provided  $\phi 8$  joint (AIR PURGE) to supply dry air for pressurizing (Fig. 2-26). The  $\phi 8$  joint (AIR PURGE) can be found at the base rear part of the robot arm. Recommended air purge equipment is shown in Table 2-10.

Table 2-9 : Specification of the dry air for pressurization

Item	Dew point	Pressure
Specification	The atmospheric pressure dew point is -20 degree or less.	0.01MPa or less

Table 2-10 : Recommended air purge equipment

Item	Part name	Required number	Manufacture
Membrane air dryer	IDG3M-02C-S	1	SMC
Precision regulator	IR1000-01G	1	SMC
Spacer (Connection part)	Y20	1	SMC

- 3) We have confirmed that the robot arm meets the protection specifications by testing it using our specified cutting oil. However, the parts of the controller may be damaged by the cutting oil. When using the controller in an oil mist environment, always use the controller protection box. Our warranty does not cover damages or failure resulting from the robot being operated in any environment where other cutting oils than those listed in the table are used (except cutting oils with respect to which the robot's compatibility with the protection specification is verified through our operability evaluation) or where the robot body may be directly splashed with water, oil or dust in quantities larger than stated in the protection specification.
- 4) Take measures so that the robot will not be exposed to water, oil and/or chips for a long period of time.

Also, entrained water droplets lead to the formation of rust on the robot, but would not usually affect the robot's ability to operate normally.

The warranty is invalid for any faults that occur when the robot is used under the following conditions.

Also, if the cover and/or other parts are damaged by interferences caused by the peripheral devices and the robot, the protection specification (seal performance, etc.) may be degraded. Therefore, please pay extra attention when handling the robot.

Refer to Page 195, "6.2 Working environment".

- 1) In surroundings that generate inflammable gases or corrosive gasses.
- 2) Atmosphere of the mist containing polish liquid etc.
- 3) Atmosphere in which the water, the oil, and the dust exceeding protection specification fall on the robot arm directly.
- 4) Pressurization by the dry air exceeding the specification of Table 2-9.

### 2.2.7 Clean specifications

The robot arm with clean specification is made by order. Please check the delivery schedule.

Table 2-11 : Clean specifications

Type	Degree of cleanliness	Internal suction	Remarks
RV-4FRC/4FRLC/4FRJLC RV-7FRC/7FRLC RV-7FRLLC RV-13FRC/13FRLC RV-20FRC	ISO class3	Concentrated suction with vacuum generating valve. Use it in the clean room with the down flow (flow velocity 0.3 m/s above).	The use of a vacuum generating valve is recommended.

#### ■ Precautions for use

- 1) A  $\phi 8$  VACUUM coupling is provided in the base section of the robot arm for vacuum inside the robot arm. (Refer to Fig. 2-26) When using the robot, connect this coupling with the vacuum generating valve (Refer to Table 2-12) and vacuum pump (furnished by the customer).
- 2) To suck in the robot arm, use the vacuum generator of the specification shown in following a) and b).
  - a) When using the vacuum generator

Table 2-12 : Specifications of vacuum generation valve (Confirmed in our company)

Type	Maker	Air pressure <sup>Note1)</sup>	Quantity
MEDT 14	KOGANEI CORPORATION	· Vacuum rate: 90.0 L/min(ANR)	1

Note1) It is the vacuum pump maker's written specification.

- b) When using the vacuum pump
 

Assure the vacuum flow rate of more than 30 L/min.

And, secure the exhaust course from the pump not to affect the power supply and the cleanliness for the vacuum pumps.



## 2.3 Names of each part of the robot

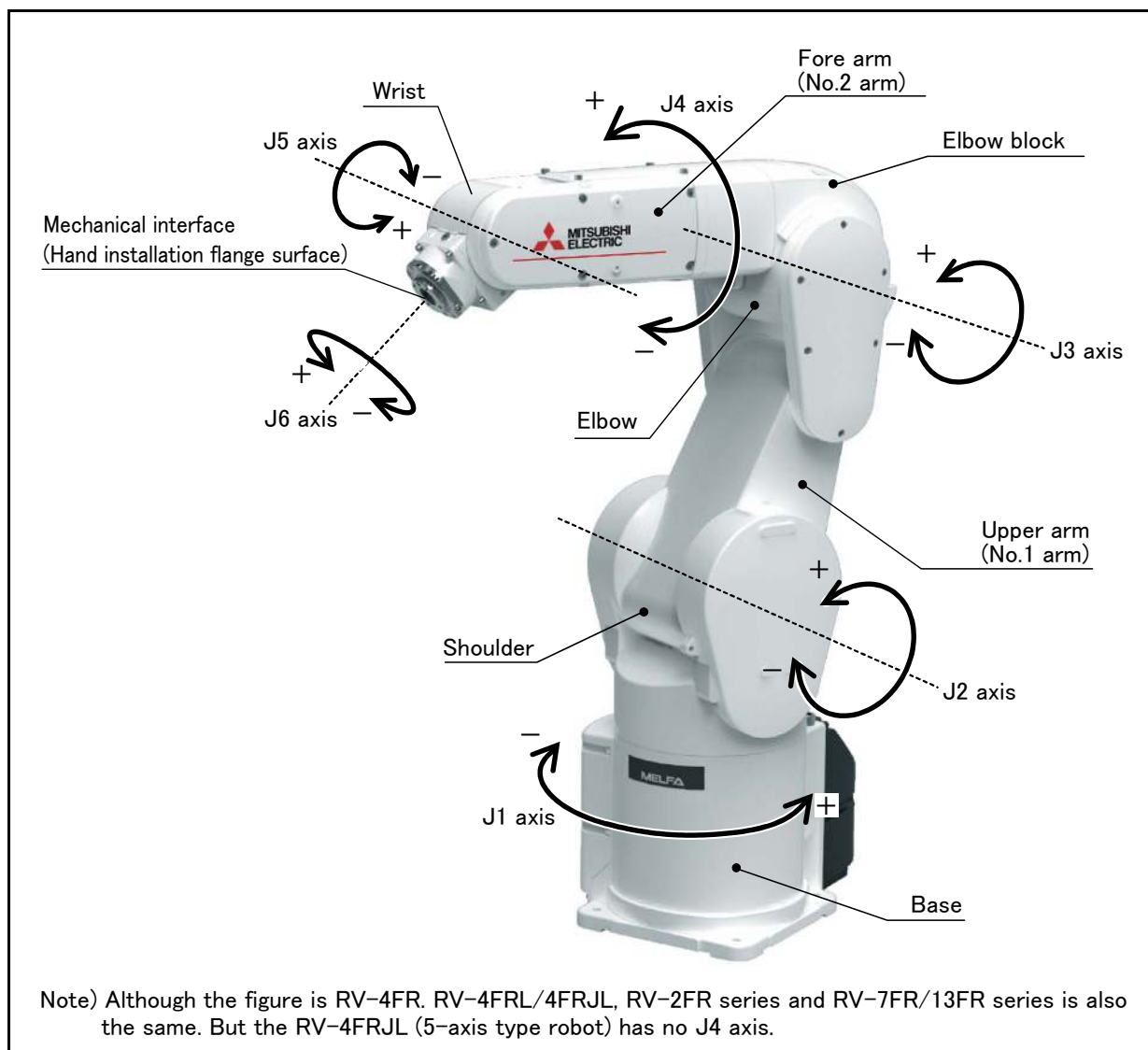

Fig.2-6 : Names of each part of the robot

2.4 Outside dimensions • Operating range diagram

(1) RV-2FR/2FRB

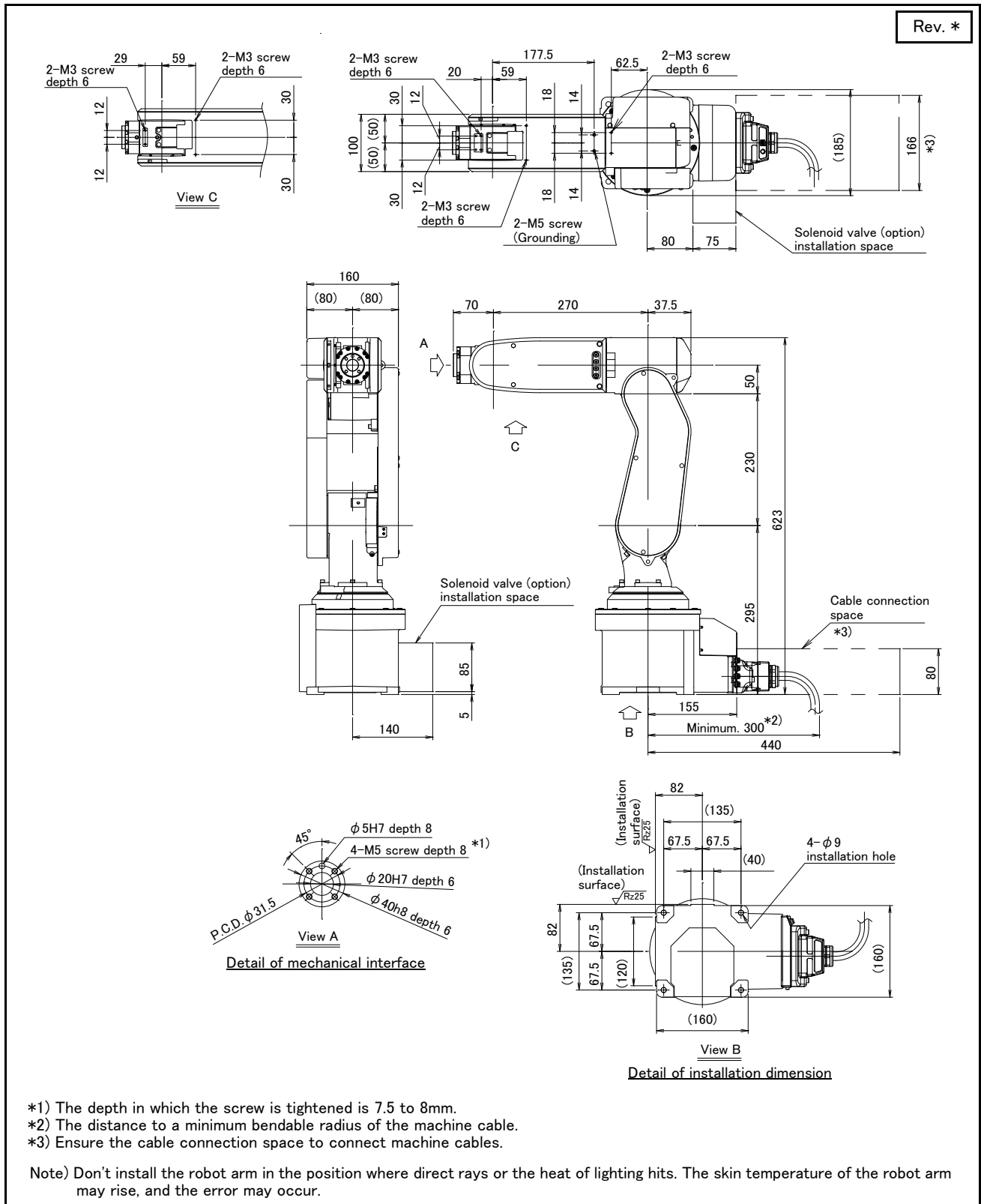

Fig.2-7 : RV-2FR/2FRB outside dimensions

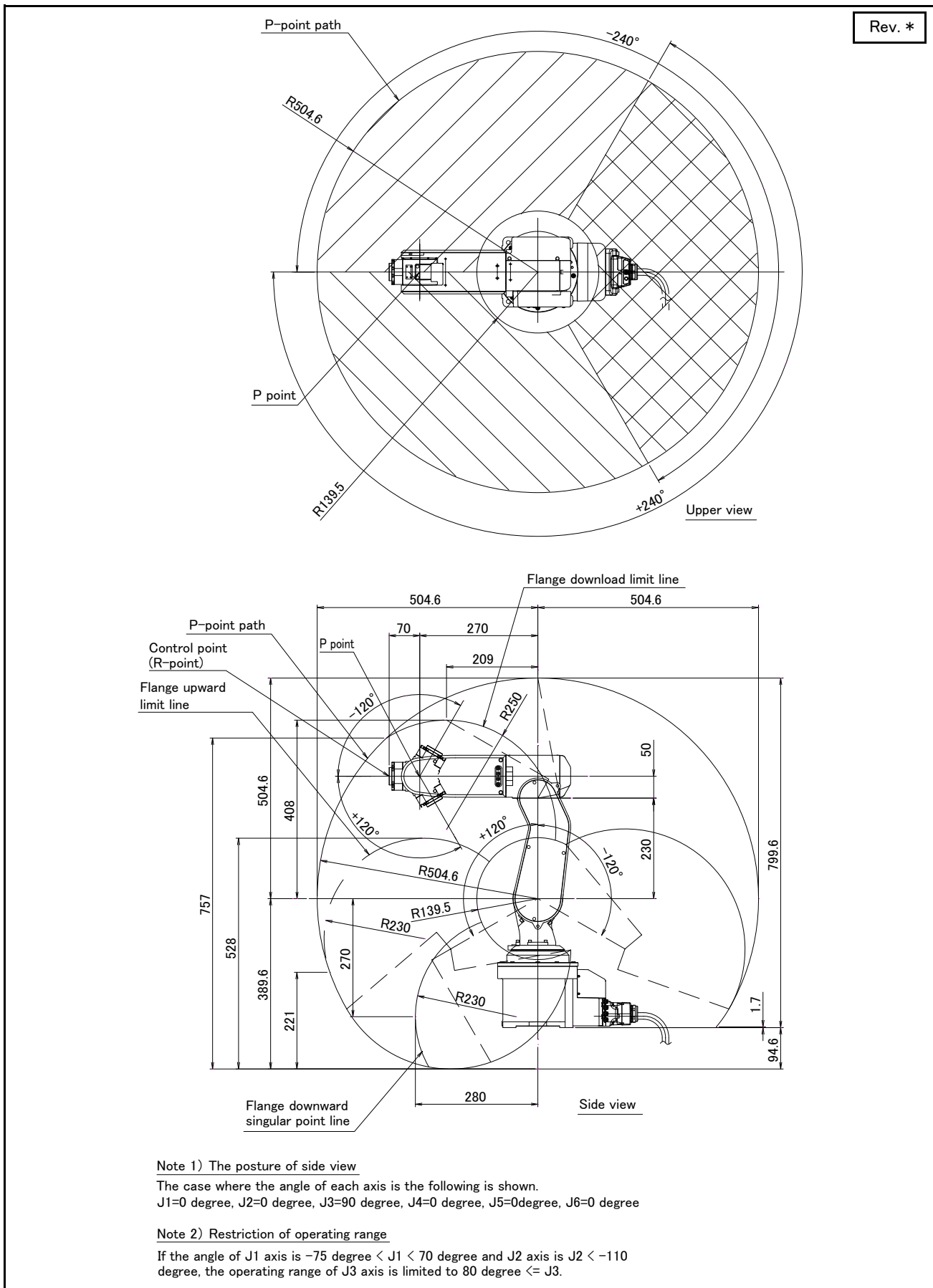
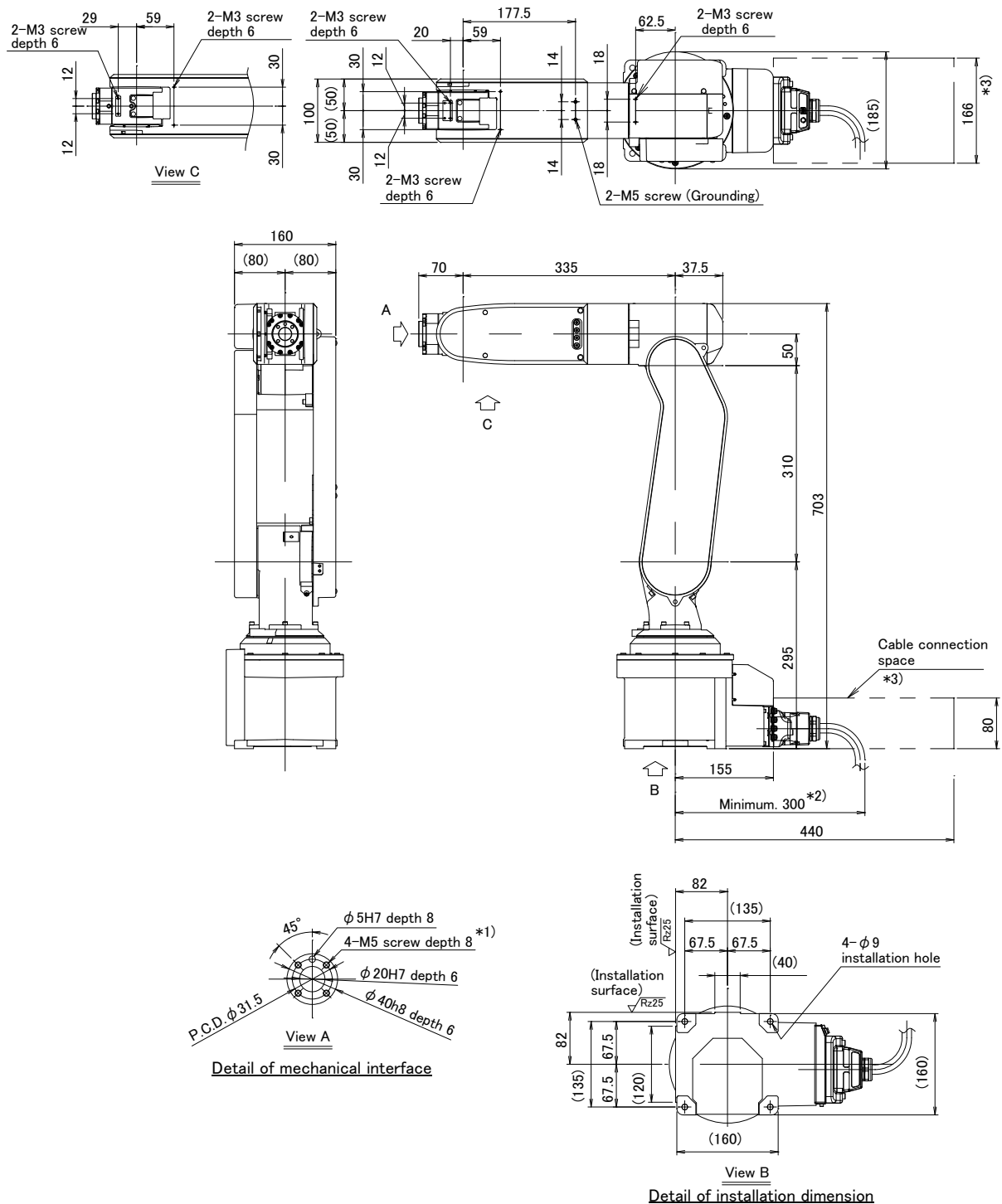

Fig.2-8 : RV-2FR/2FRB operating range diagram

(2) RV-2FRL/2FRLB

Rev. \*



- \*1) The depth in which the screw is tightened is 7.5 to 8mm.
- \*2) The distance to a minimum bendable radius of the machine cable.
- \*3) Ensure the cable connection space to connect machine cables.

Note) Don't install the robot arm in the position where direct rays or the heat of lighting hits. The skin temperature of the robot arm may rise, and the error may occur.

Fig.2-9 : RV-2FRL/2FRLB outside dimensions

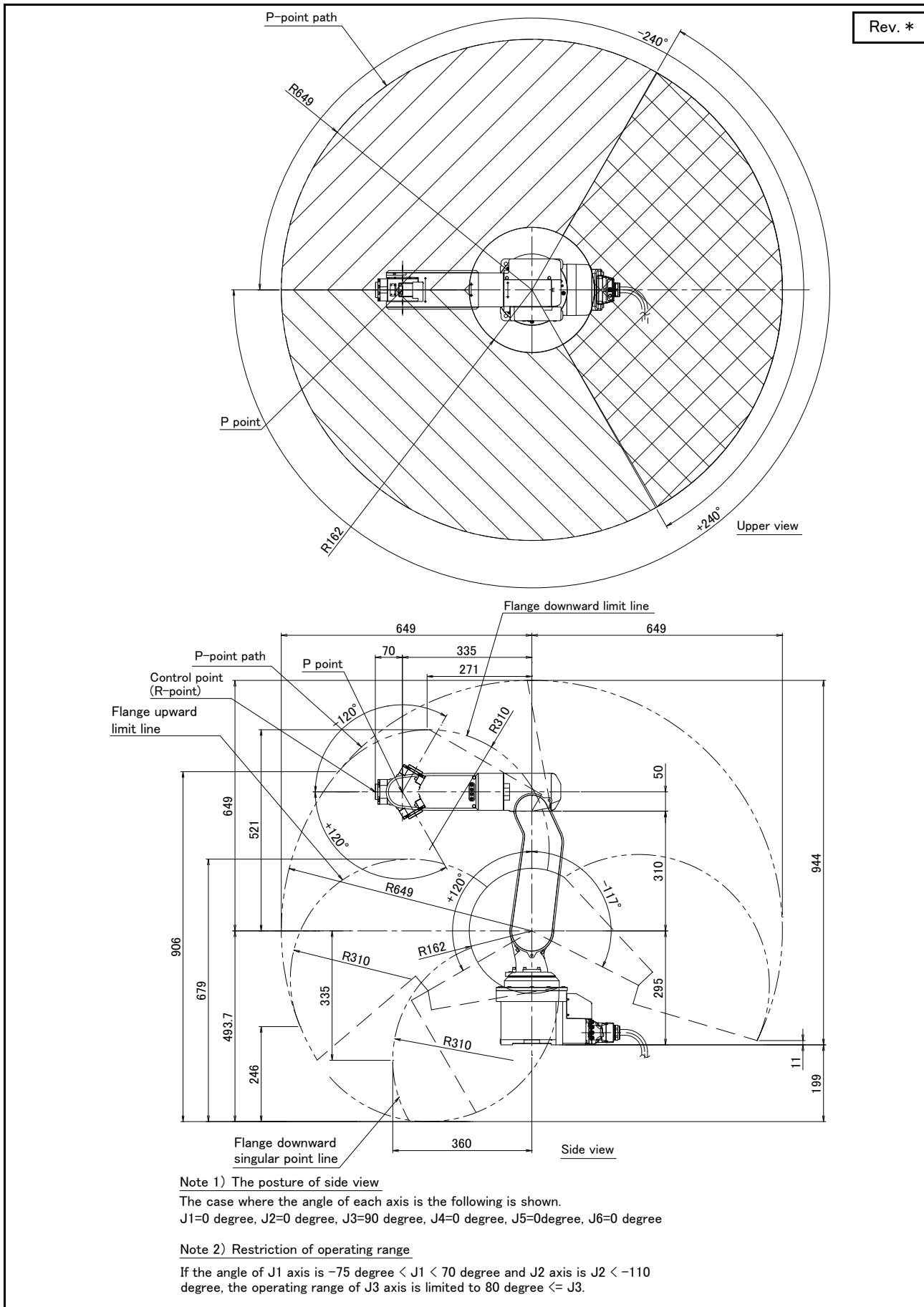

Fig.2-10 : RV-2FRL/2FRLB operating range diagram

(3) RV-4FR

Notes

Rev. \*

1. \*1) Ensure the cable connection space to connect machine cables.
2. \*2) Ensure the maintenance space to take out the cover.
3. \*3) The screw should go in to a depth of 7.5mm to 8mm.
4. \*4) Screw hole (M4 depth 8) for securing the user cables/piping.
5. \*5) The size of the internal wiring and piping specification model (-SHxx).
6. \*6) The depth is 6mm for the normal specification, 3.5mm for the clean/oil mist specification and 6.5mm for -SH\*\* specification.
7. \*7) The dimension a shows the distance to a minimum bendable radius of the machine cable.

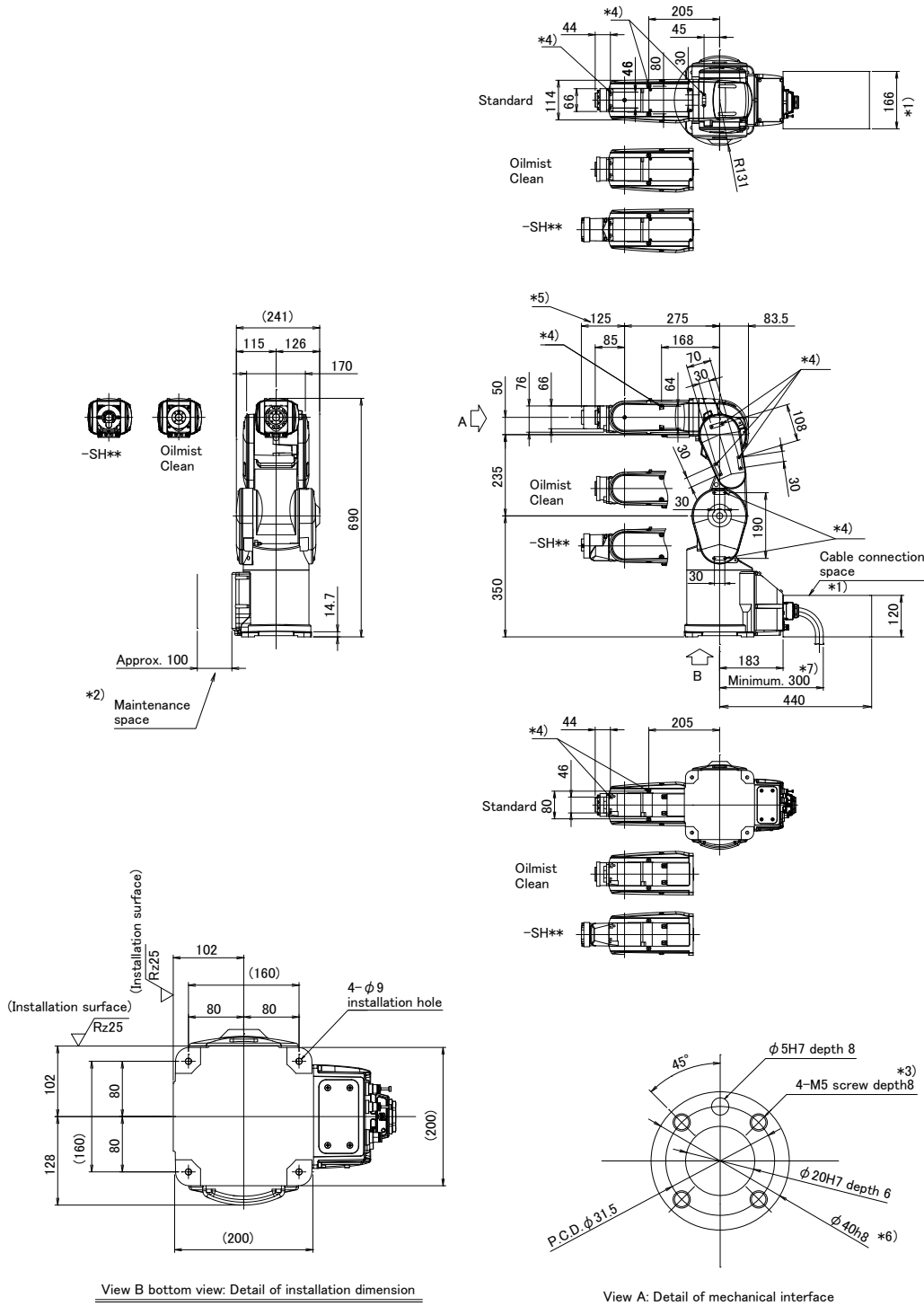

Note) Don't install the robot arm in the position where direct rays or the heat of lighting hits. The skin temperature of the robot arm may rise, and the error may occur.

Fig.2-11 : Outside dimensions: RV-4FR

Rev. \*

**Notes**

1. \*1) Rear face operation limit: When the J axis angle is  $-60^\circ \leq J1 \leq +140^\circ$ , the J2 axis operation is limited to  $-113^\circ \leq J2 \leq +120^\circ$ .
2. The following figure shows a robot at the position of:  $J1=0^\circ, J2=0^\circ, J3=90^\circ, J4=0^\circ, J5=0^\circ$ , and  $J6=0^\circ$
3. \*3) The area which P point cannot be moved: P point cannot move to this area. This limitation is valid at factory shipping, but it can be released by parameter MELTEXS.

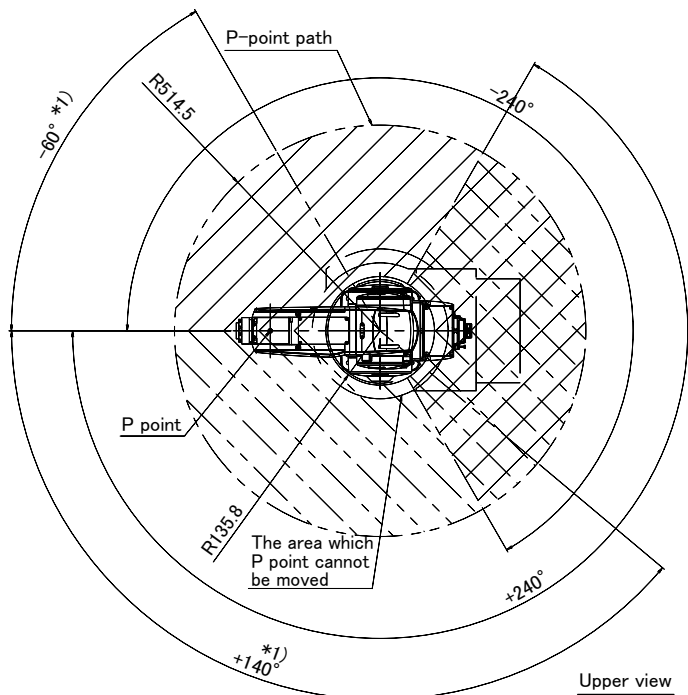

Operating range for each axis:  
 J1:  $\pm 240^\circ$   
 J2:  $\pm 120^\circ$   
 J3:  $0^\circ$  to  $161^\circ$   
 J4:  $\pm 200^\circ$   
 J5:  $\pm 120^\circ$   
 J6:  $\pm 360^\circ$   
 J6 when -SH specifications are used:  $\pm 200^\circ$

For internal wiring and piping specification (-SHxx)

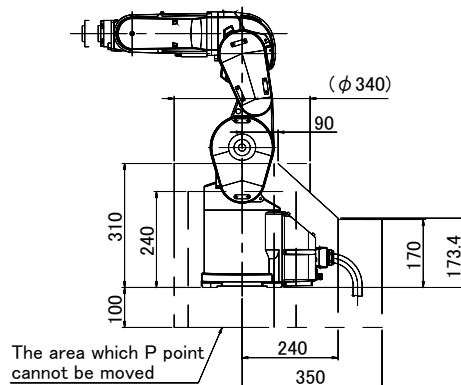
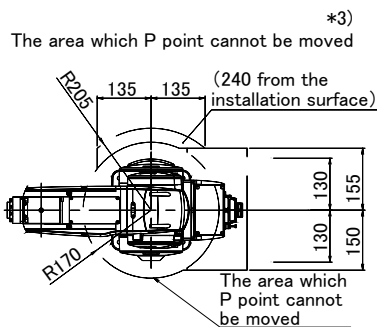
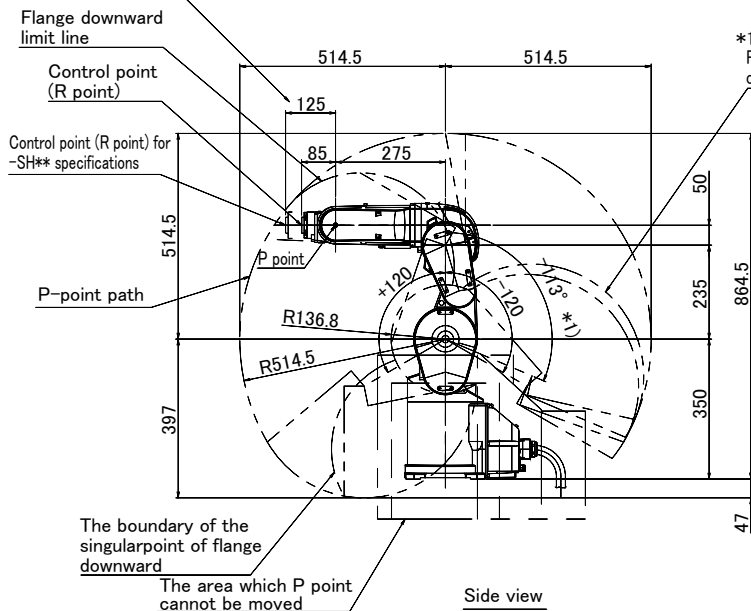

Fig.2-12 : Operating range diagram: RV-4FR





Rev. \*

**Notes**

1. \*1) Rear face operation limit: When the J axis angle is  $-35^\circ \leq J1 \leq +35^\circ$ , the J2 axis operation is limited to  $-114^\circ \leq J2 \leq +120^\circ$ .
2. The following figure shows a robot at the position of:  $J1=0^\circ, J2=0^\circ, J3=90^\circ, J4=0^\circ, J5=0^\circ$ , and  $J6=0^\circ$
3. \*3) The area which P point cannot be moved: P point cannot move to this area. This limitation is valid at factory shipping, but it can be released by parameter MELTEXS.

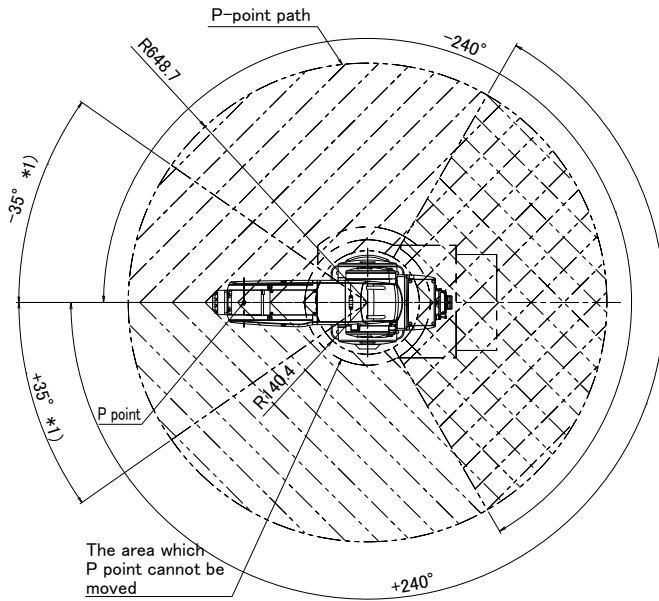

Operating range for each axis:  
 J1:  $\pm 240^\circ$   
 J2:  $\pm 120^\circ$   
 J3:  $0^\circ$  to  $164^\circ$   
 J4:  $\pm 200^\circ$   
 J5:  $\pm 120^\circ$   
 J6:  $\pm 360^\circ$   
 J6 when -SH specifications are used:  $\pm 200^\circ$

Upper view

For internal wiring and piping specification (-SH\*\*)

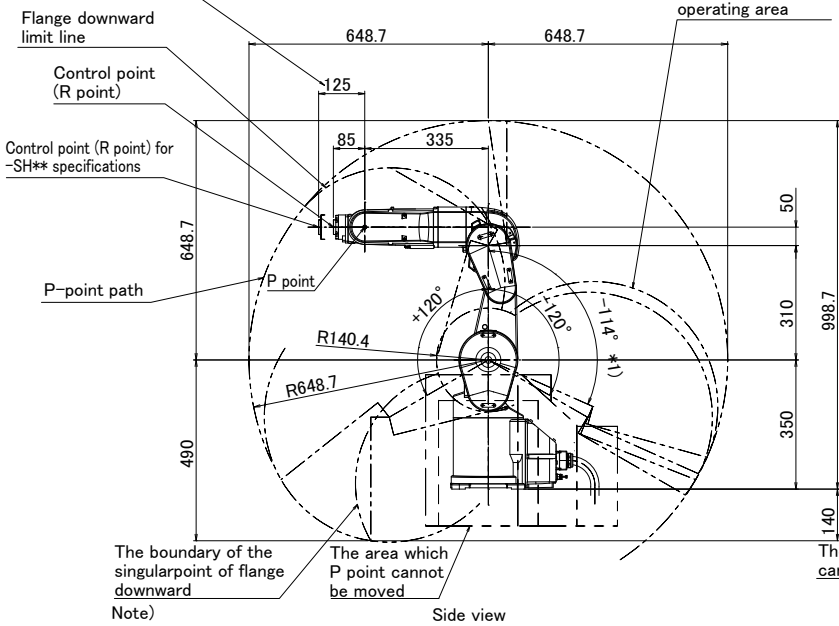

\*3) The area which P point cannot be moved

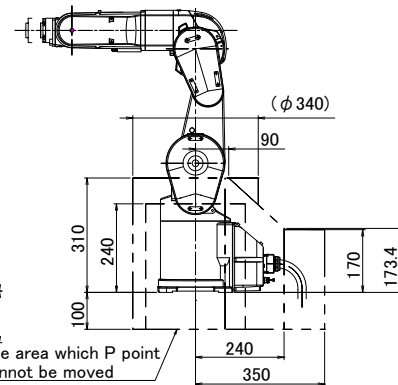
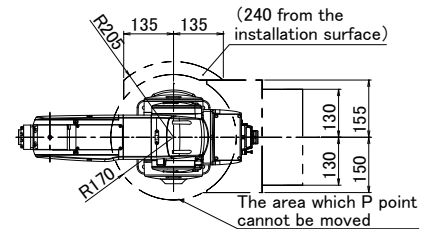

Note) RV-4FRJL does not have this.

Fig.2-14 : Operating range diagram: RV-4FRL/4FRJL



Rev. \*

**Notes**

1. The following figure shows a robot at the position of:  
 $J1=0^\circ$ ,  $J2=0^\circ$ ,  $J3=90^\circ$ ,  $J4=0^\circ$ ,  $J5=0^\circ$ , and  $J6=0^\circ$
2. \*1) The area which P point cannot be moved: P point cannot move to this area. This limitation is valid at factory shipping, but it can be released by parameter MELTEXS.

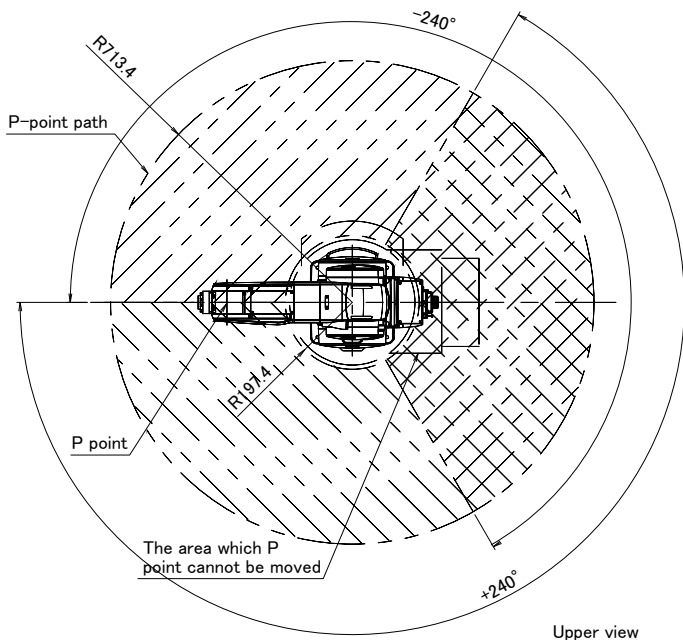

Operating range for each axis:  
 $J1: \pm 240^\circ$   
 $J2: -115^\circ \text{ to } 125^\circ$   
 $J3: 0^\circ \text{ to } 156^\circ$   
 $J4: \pm 200^\circ$   
 $J5: \pm 120^\circ$   
 $J6: \pm 360^\circ$   
 $J6 \text{ when -SH specifications are used: } \pm 200^\circ$

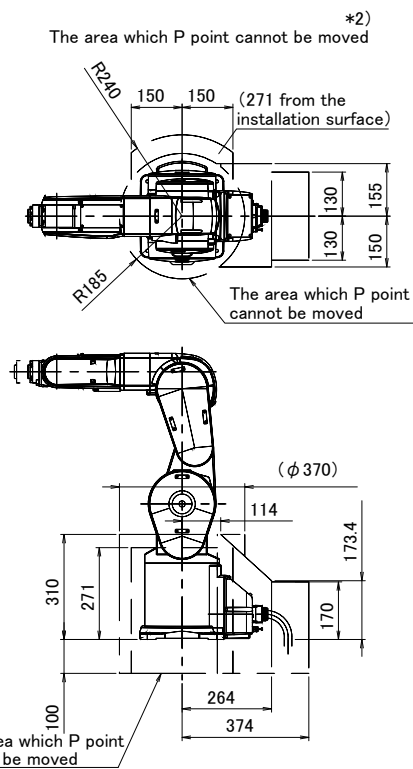
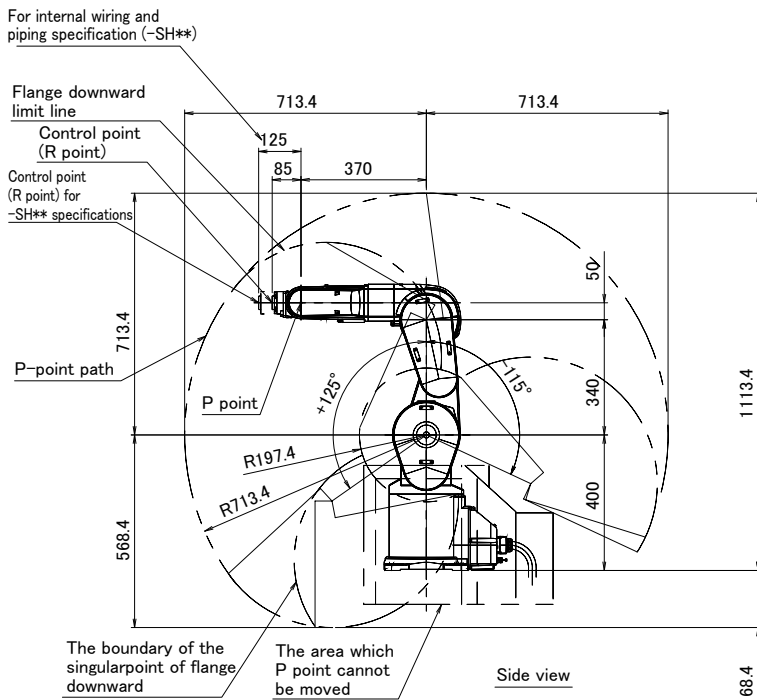

Fig.2-16 : Operating range diagram: RV-7FR

(6) RV-7FRL

Notes

Rev. \*

1. \*1) Ensure the cable connection space to connect machine cables.
2. \*2) Ensure the maintenance space to take out the cover.
3. \*3) The screw should go in to a depth of 7.5mm to 8mm.
4. \*4) Screw hole (M4 depth 8) for securing the user cables/piping.
5. \*5) The size of the internal wiring and piping specification model (-SHxx).
6. \*6) The depth is 6mm for the normal specification, 3.5mm for the clean/oil mist specification and 6.5mm for -SH\*\* specification.
7. \*7) The dimension a shows the distance to a minimum bendable radius of the machine cable.

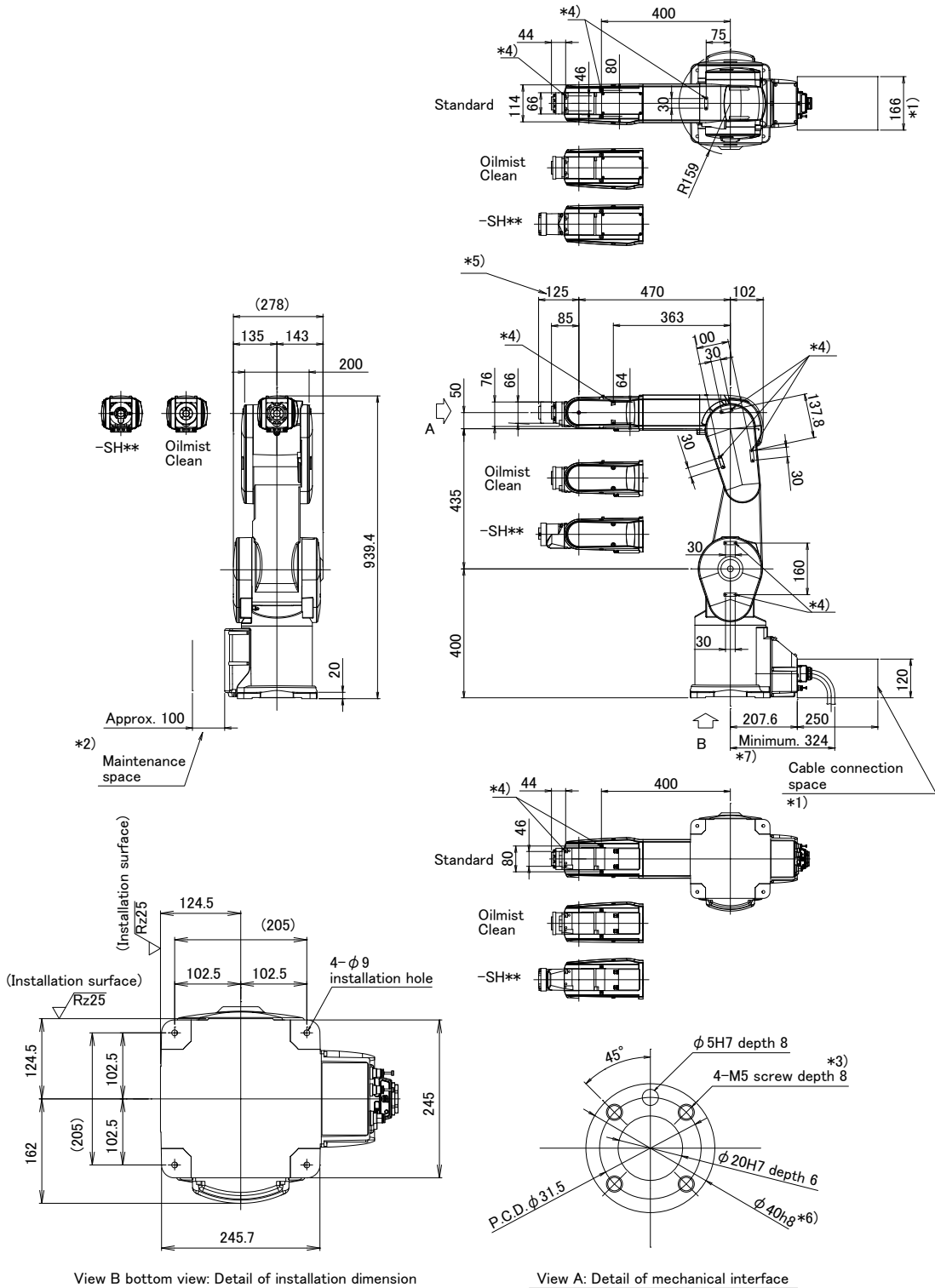

Note) Don't install the robot arm in the position where direct rays or the heat of lighting hits. The skin temperature of the robot arm may rise, and the error may occur.

Fig.2-17 : Outside dimensions: RV-7FRL

Notes

Rev. \*

1. The following figure shows a robot at the position of:  
 $J1=0^\circ$ ,  $J2=0^\circ$ ,  $J3=90^\circ$ ,  $J4=0^\circ$ ,  $J5=0^\circ$ , and  $J6=0^\circ$
2. \*1) Front face operation limit: When the  $J1$  axis angle is  $+145^\circ \leq J1 \leq +215^\circ$  or  $-145^\circ \leq J1 \leq -215^\circ$ , the  $J2$  axis operation is limited to  $-110^\circ \leq J2 \leq +120^\circ$ .
3. \*2) The area which P point cannot be moved: P point cannot move to this area. This limitation is valid at factory shipping, but it can be released by parameter MELTEXS.

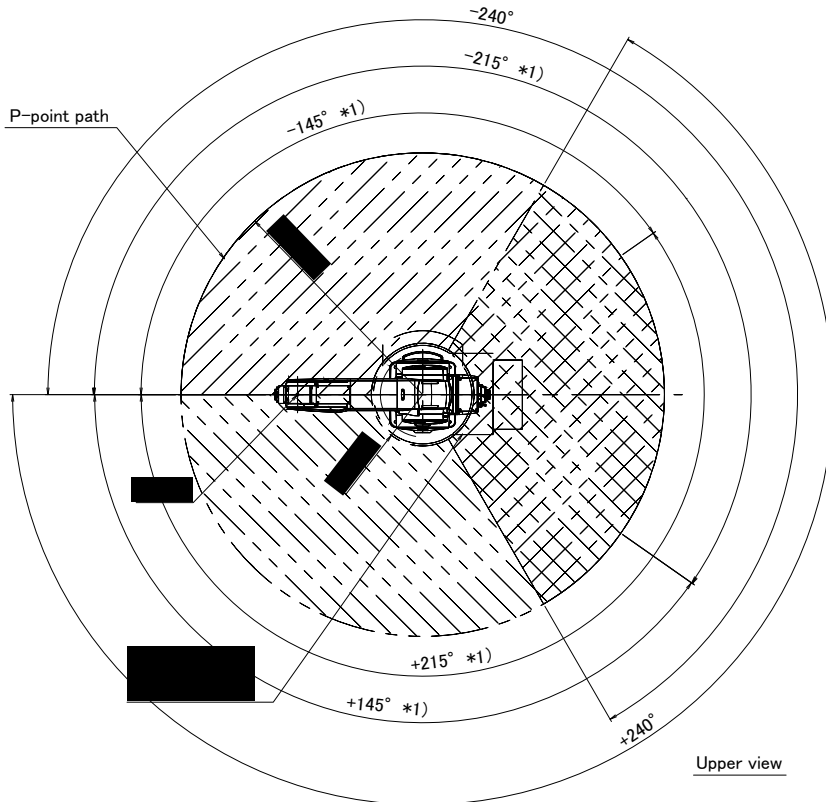

Operating range for each axis:  
 $J1: \pm 240^\circ$   
 $J2: -110^\circ$  to  $130^\circ$   
 $J3: 0^\circ$  to  $162^\circ$   
 $J4: \pm 200^\circ$   
 $J5: \pm 120^\circ$   
 $J6: \pm 360^\circ$   
 $J6$  when -SH specifications are used:  $\pm 200^\circ$

Upper view

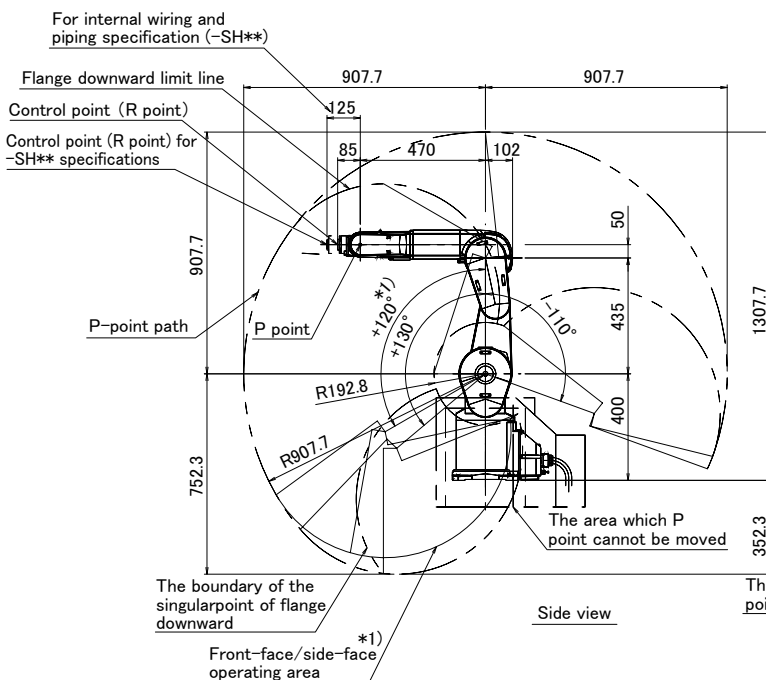

Side view

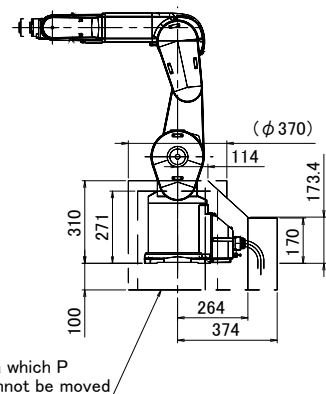
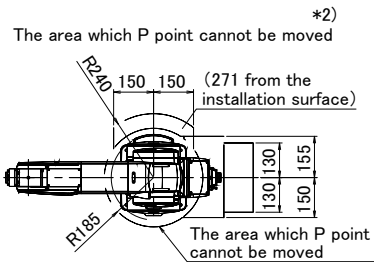

Fig.2-18 : Operating range diagram: RV-7FRL

(7) RV-7FRLL

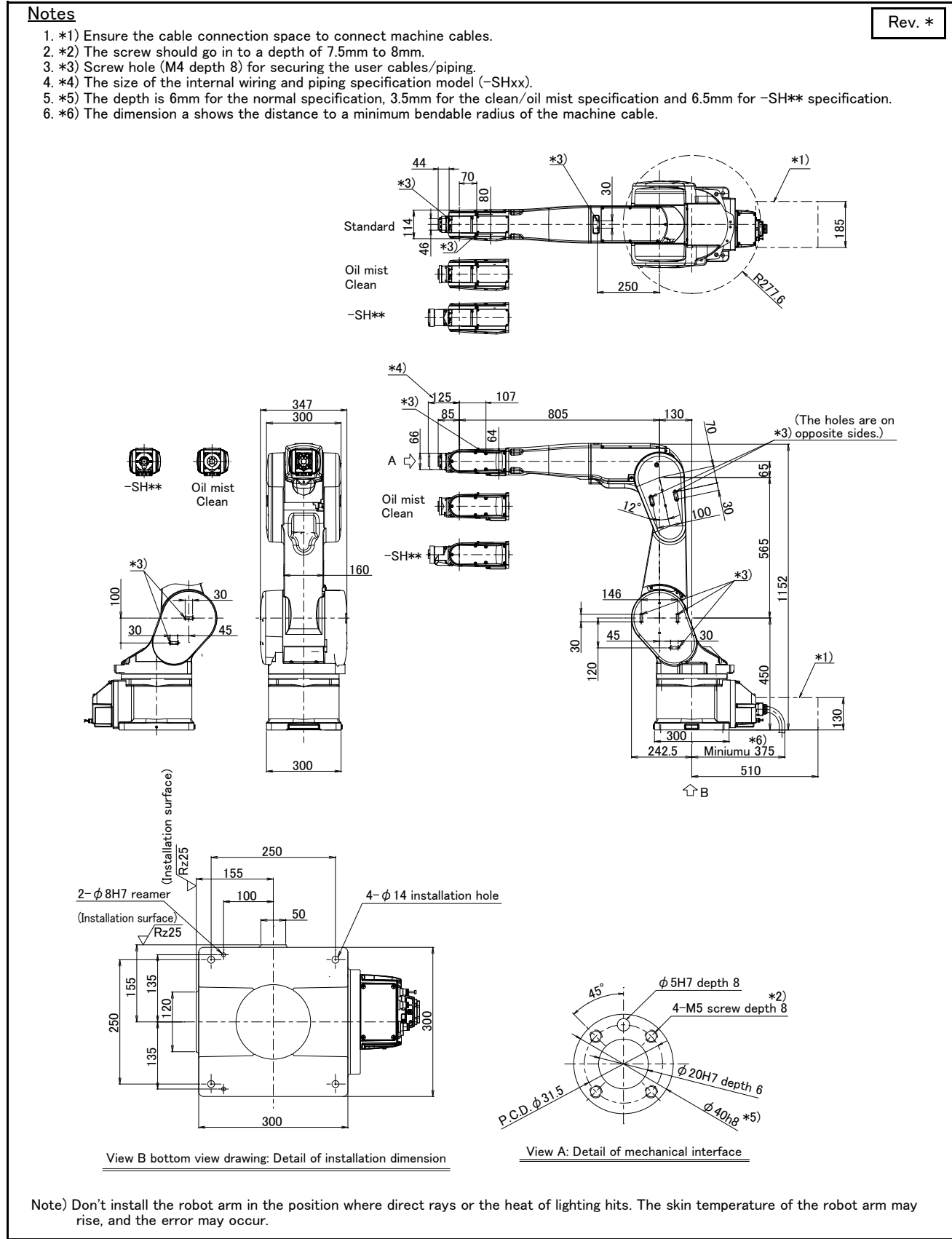
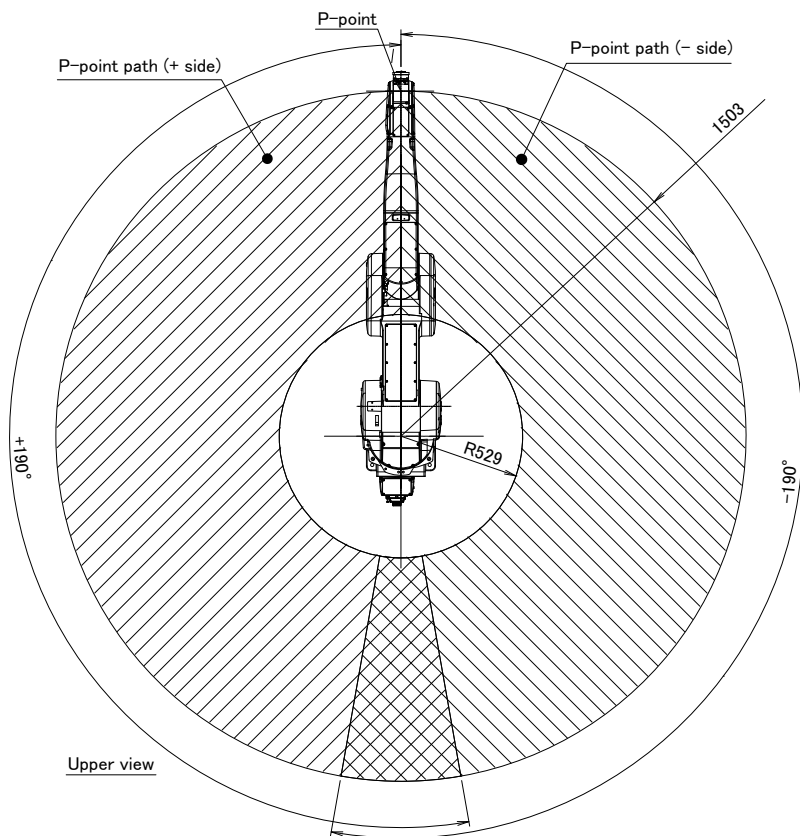

Fig.2-19 : Outside dimensions: RV-7FRLL

Notes

Rev. \*

1. The side view figure shows a robot at the position of:  
 $J1=0^\circ, J2=0^\circ, J3=90^\circ, J4=0^\circ, J5=0^\circ,$  and  $J6=0^\circ$
2. \*1) Front face operation limit: When the J1 axis angle is  $+120^\circ \leq J1$  or  $J1 \leq -120^\circ$ , the J2 axis operation is limited to  $-90^\circ \leq J2 \leq +130^\circ$ .
3. \*2) The area which P point cannot be moved: P point cannot move to this area. This limitation is valid at factory shipping, but it can be released by parameter MELTEXS.



Operating range of each axis:  
 J1:  $\pm 190^\circ$   
 J2:  $-90^\circ$  to  $+150^\circ$   
 J3:  $-10^\circ$  to  $+157.5^\circ$   
 J4:  $\pm 200^\circ$   
 J5:  $\pm 120^\circ$   
 J6:  $\pm 360^\circ$   
 J6 when -SH specifications are used:  $\pm 200^\circ$

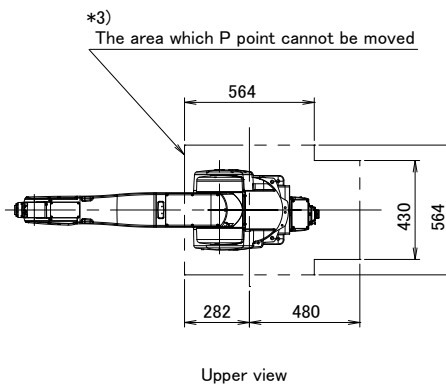
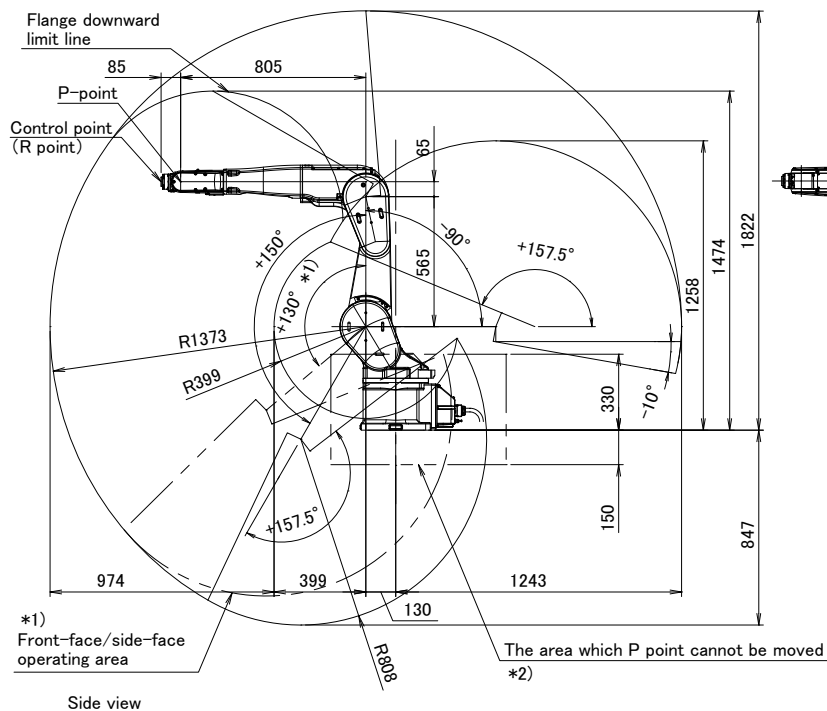

Fig.2-20 : Operating range diagram: RV-7FRLL

(8) RV-13FR/20FR

Notes

1. \*1) Ensure the cable connection space to connect machine cables.
2. \*2) The screw should go in to a depth of 9mm to 10mm.
3. \*3) Screw hole (M4 depth 8) for securing the user cables/piping.
4. \*4) The size of the internal wiring and piping specification model (-SHxx).
5. \*5) The dimension a shows the distance to a minimum bendable radius of the machine cable.

Rev. \*

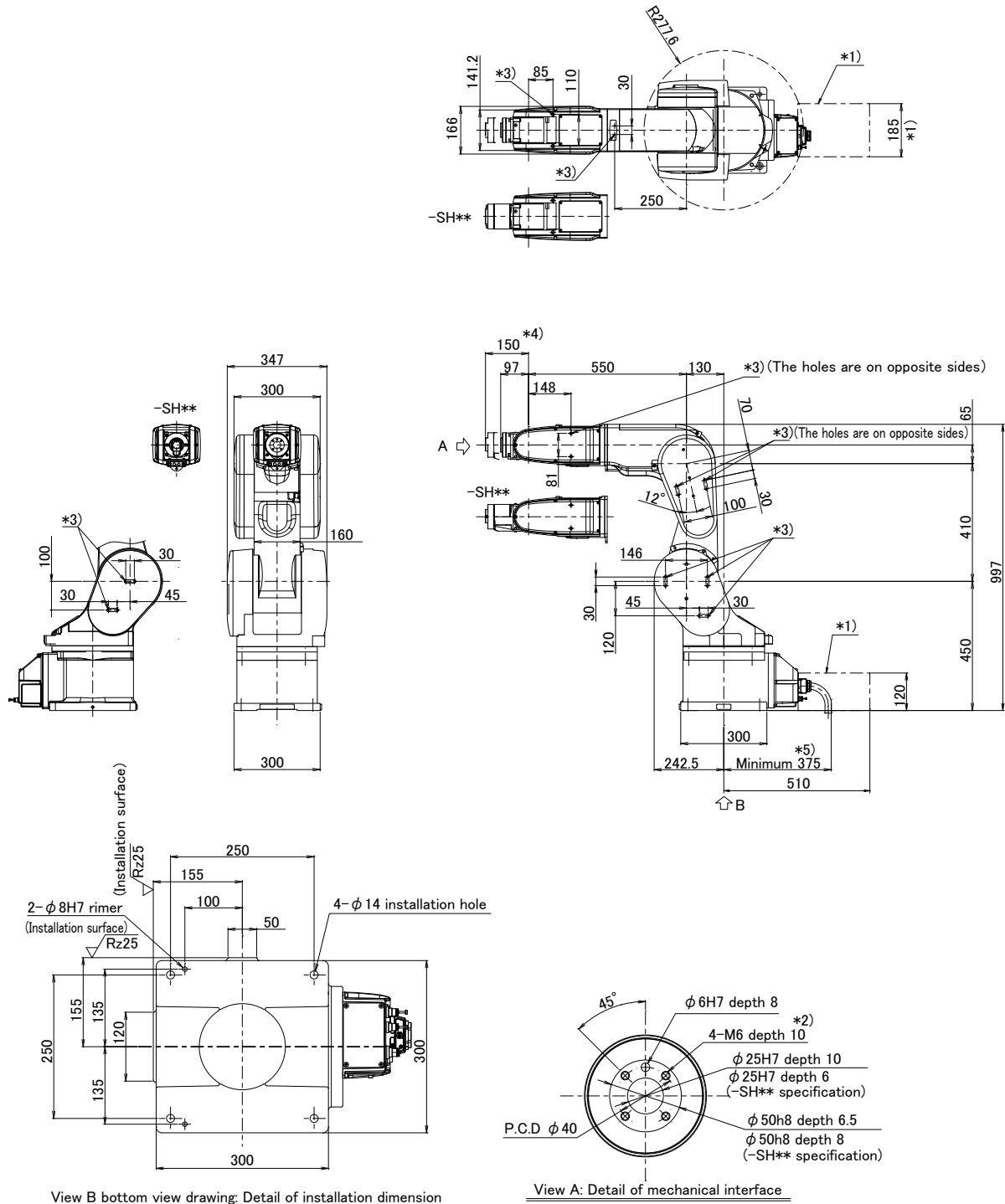

Note) Don't install the robot arm in the position where direct rays or the heat of lighting hits. The skin temperature of the robot arm may rise, and the error may occur.

Fig.2-21 : Outside dimensions: RV-13FR/20FR



Rev. \*

Notes

1. The side view figure shows a robot at the position of:  
 $J1=0^\circ, J2=0^\circ, J3=90^\circ, J4=0^\circ, J5=0^\circ,$  and  $J6=0^\circ$
2. \*1) Front face operation limit: When the J1 axis angle is  $+120^\circ \leq J1$  or  $J1 \leq -130^\circ$ , the J2 axis operation is limited to  $-90^\circ \leq J2 \leq +130^\circ$ .
3. \*2) The area which P point cannot be moved: P point cannot move to this area. This limitation is valid at factory shipping, but it can be released by parameter MELTEXS.

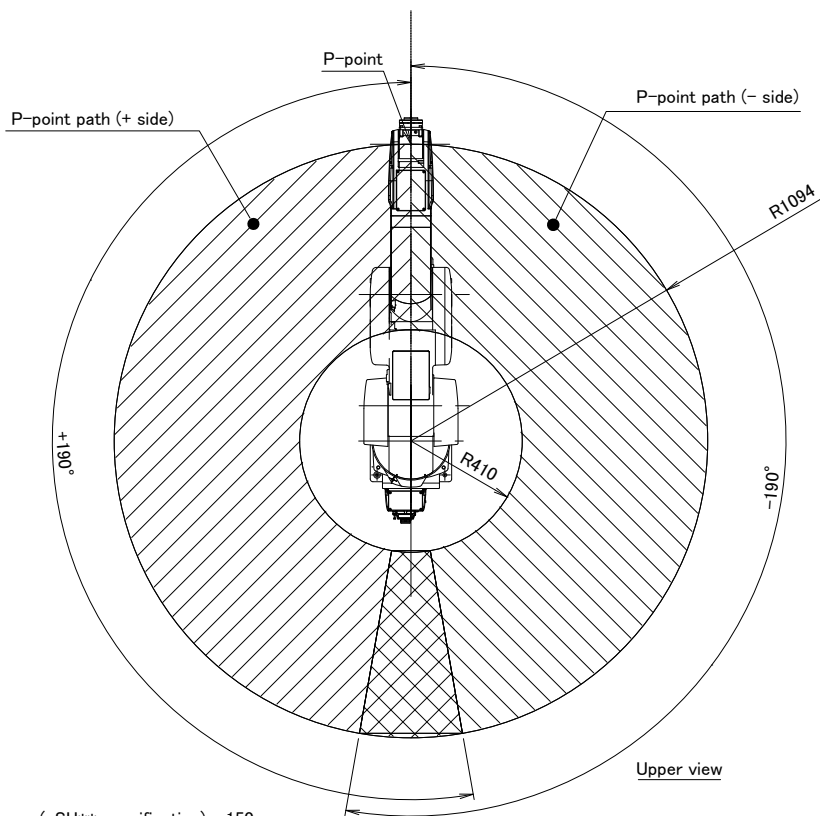

Operating range of each axis:  
 J1:  $\pm 190^\circ$   
 J2:  $-90^\circ$  to  $+150^\circ$   
 J3:  $-10^\circ$  to  $+157.5^\circ$   
 J4:  $\pm 200^\circ$   
 J5:  $\pm 120^\circ$   
 J6:  $\pm 360^\circ$   
 J6 when -SH specifications are used:  $\pm 200^\circ$

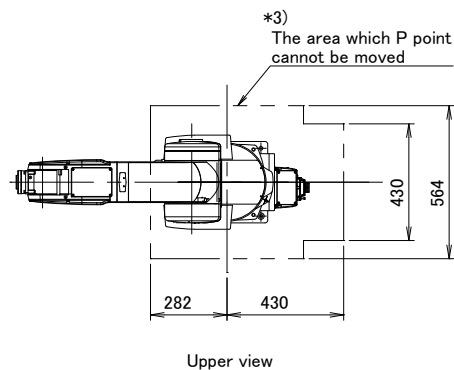
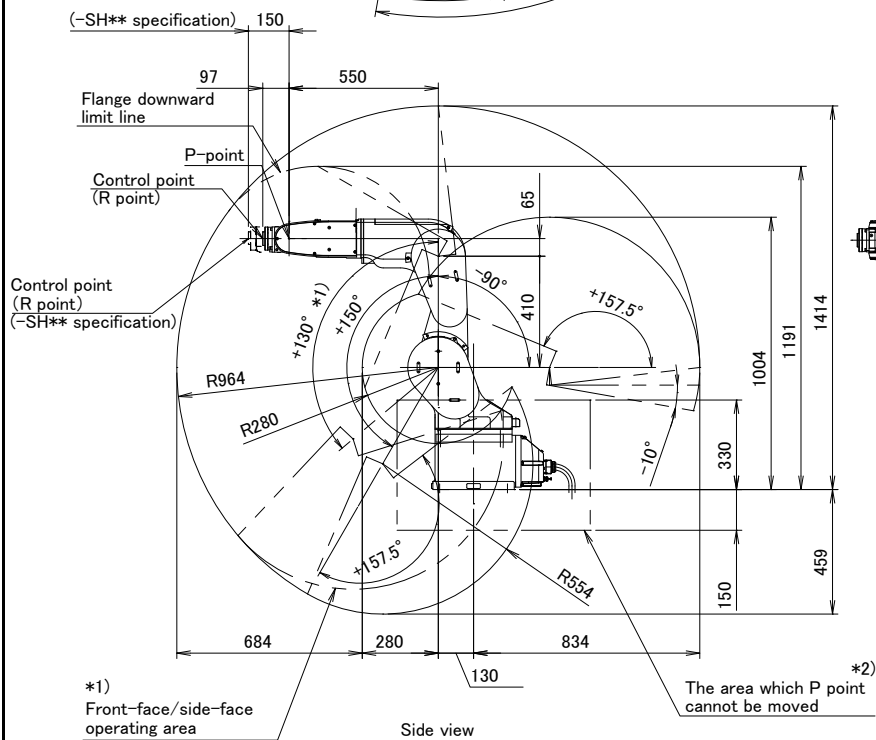

Fig.2-22 : Operating range diagram: RV-13FR/20FR

(9) RV-13FRL

Notes

Rev. \*

1. \*1) Ensure the cable connection space to connect machine cables.
2. \*2) The screw should go in to a depth of 9mm to 10mm.
3. \*3) Screw hole (M4 depth 8) for securing the user cables/piping.
4. \*4) The size of the internal wiring and piping specification model (-SHxx).
5. \*5) The dimension a shows the distance to a minimum bendable radius of the machine cable.

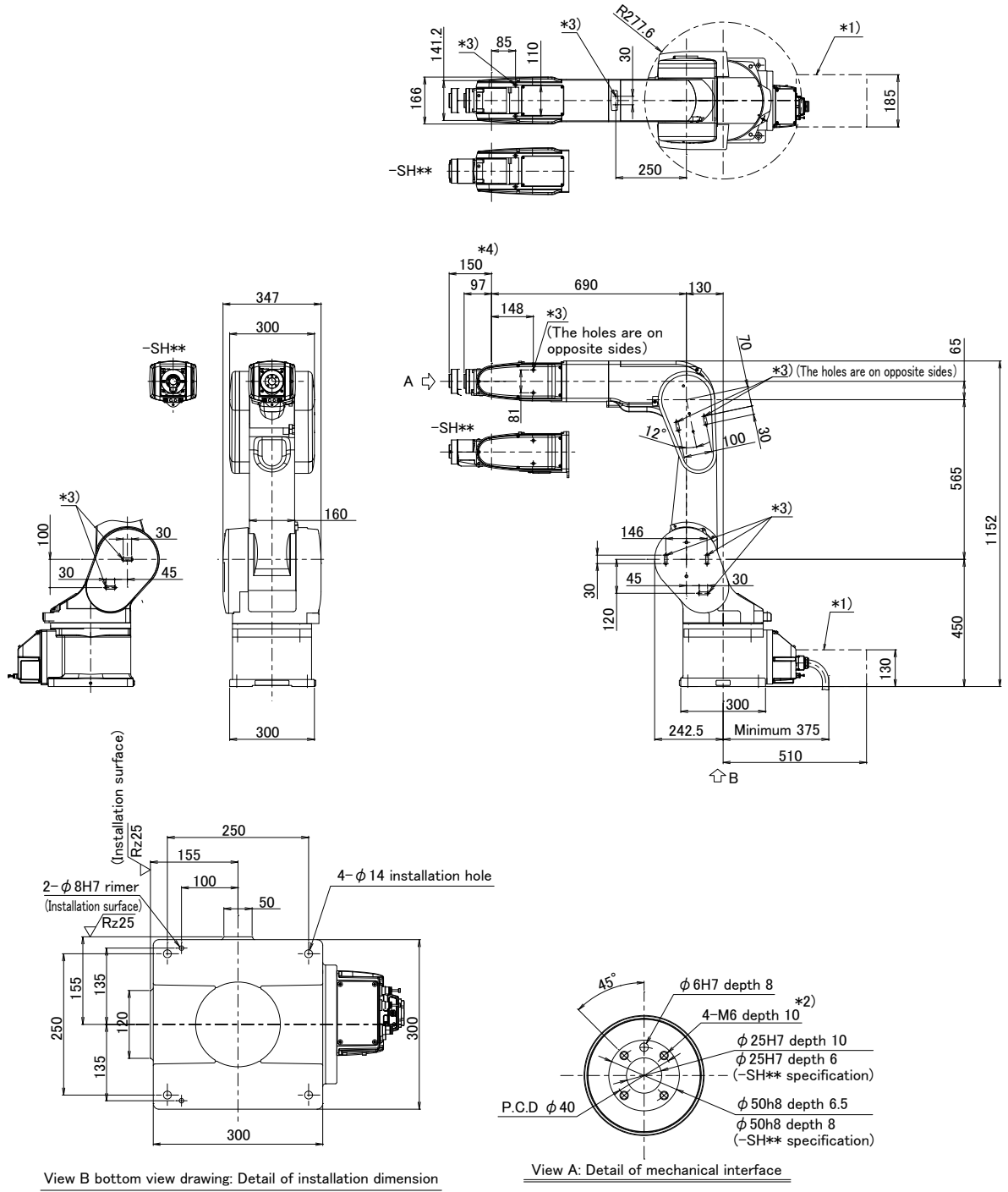

Note) Don't install the robot arm in the position where direct rays or the heat of lighting hits. The skin temperature of the robot arm may rise, and the error may occur.

Fig.2-23 : Outside dimensions: RV-13FRL



### 2.4.1 Outside dimensions of machine cables

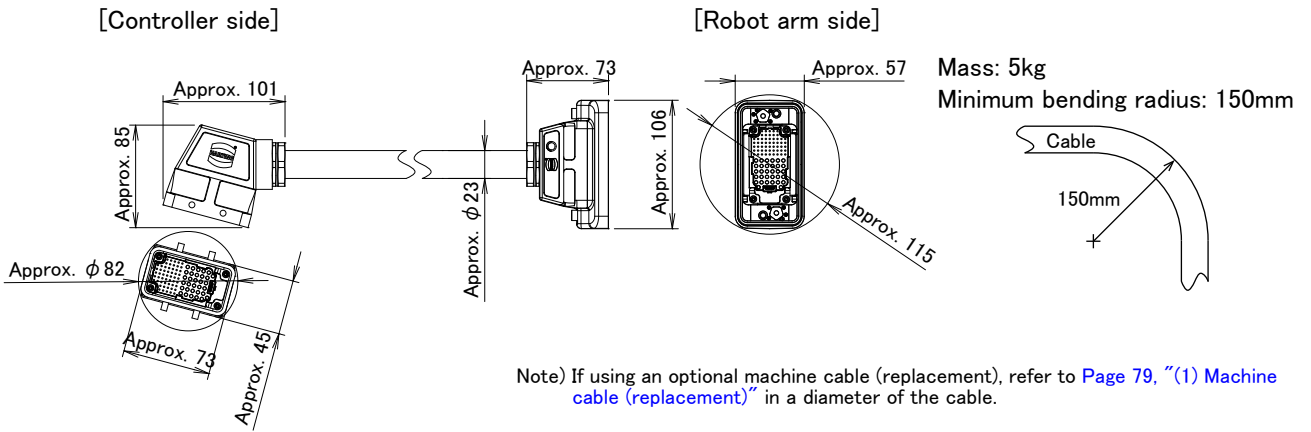

## 2.5 Tooling

### 2.5.1 Wiring and piping for hand

Shows the wiring and piping configuration for a standard-equipped hand.

#### (1) RV-2FR series

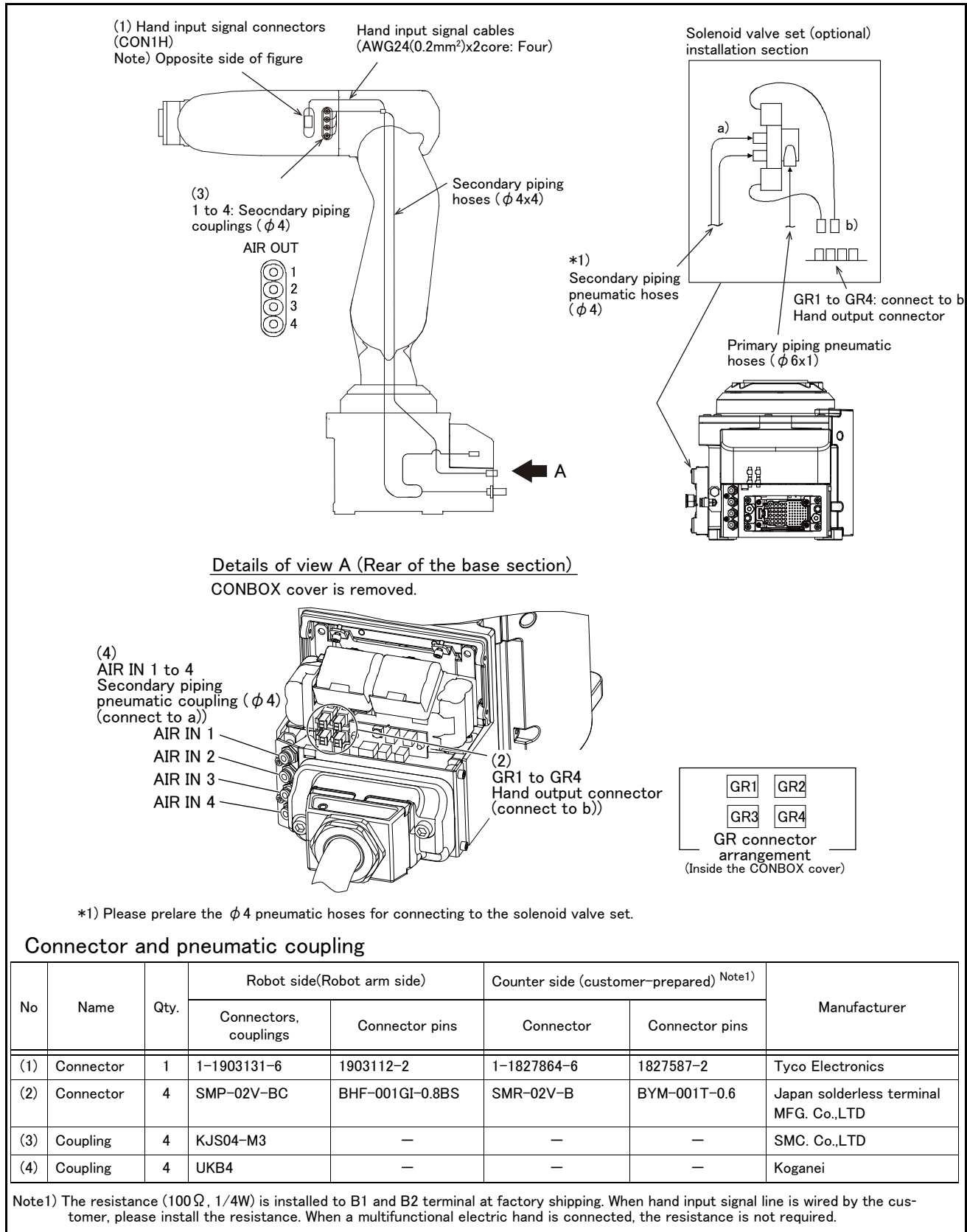

Fig.2-25 : RV-2FR series wiring and piping for hand

(2) RV-4FR/7FR/13FR series standard specification (with no internal wiring and piping)

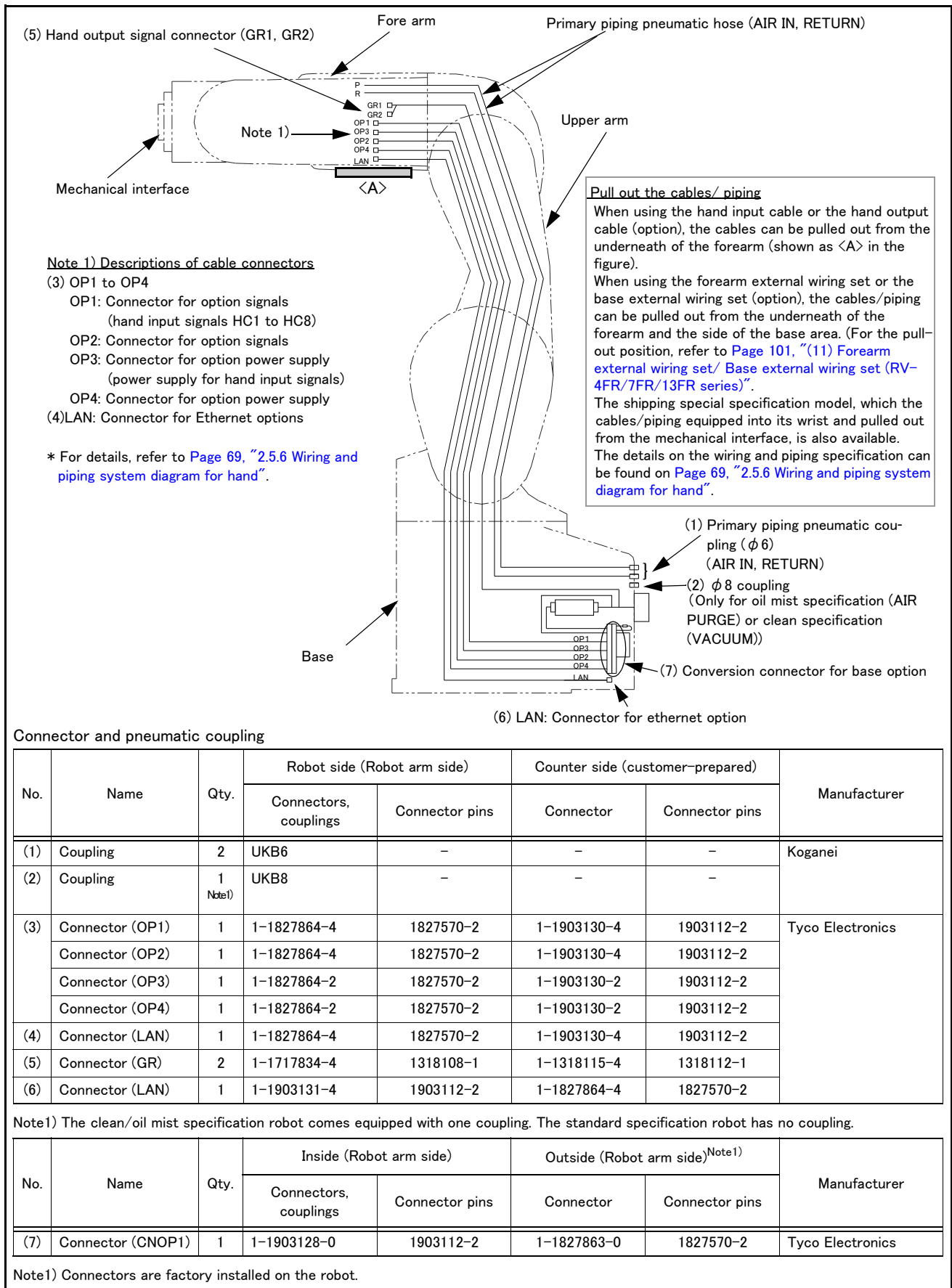
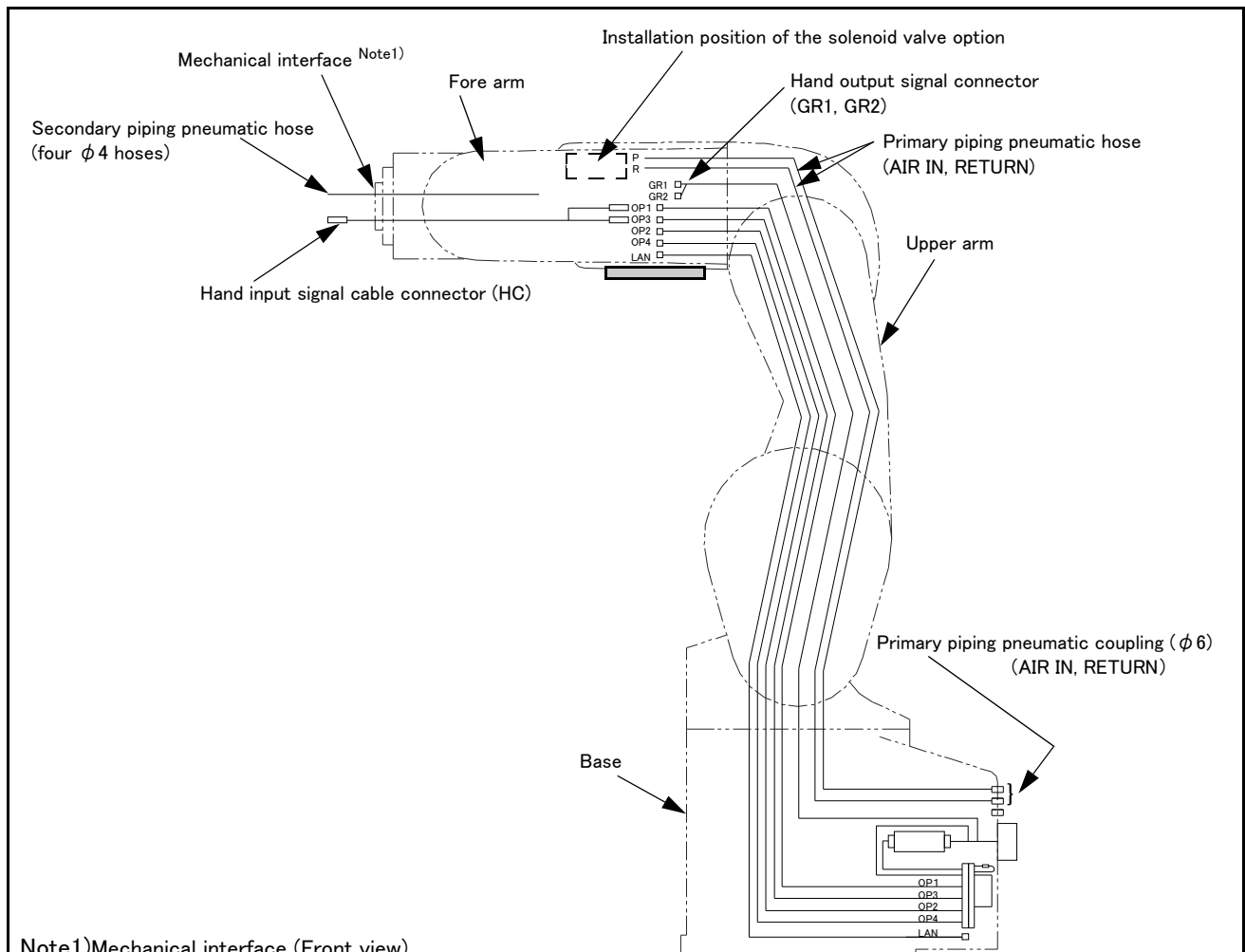

Fig.2-26 : RV-4FR/7FR/13FR series wiring and piping for hand

(3) RV-4F/7F/13F series internal wiring and piping specification (SH01)



Note 1) Mechanical interface (Front view)

RV-4FR/7FR series, RV-7FRLL

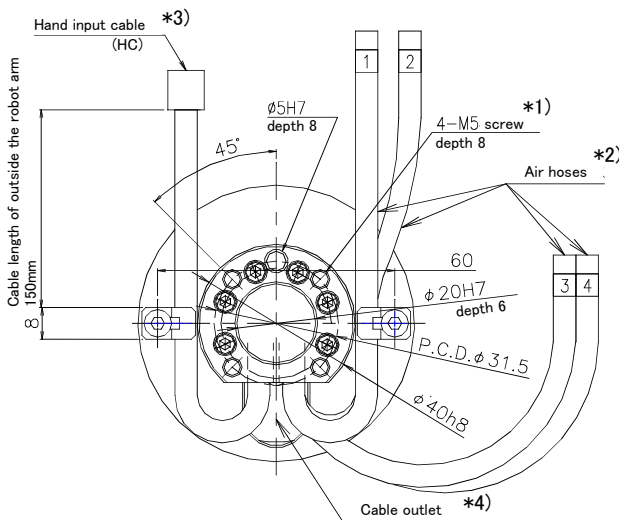

RV-13FR/13FRL, RV-20FR

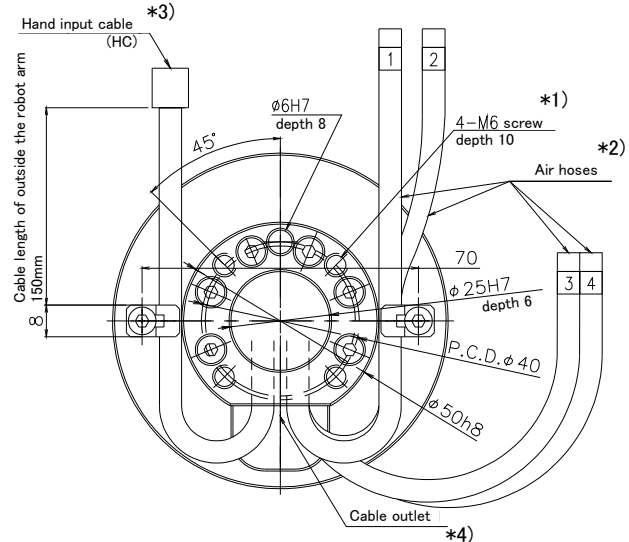

- \*1) The screws should go in to a depth of shown below.  
 RV-4FR/7FR series, RV-7FRLL.....7.5mm to 8mm  
 RV-13FR/13FRL, RV-20FR.....9mm to 10mm
- \*2) Four air tubes have numbered marking tube. Those lengths from the cable outlet are 300 mm.
- \*3) Refer to Fig. 2-34 for pin assignment of the hand input cable (HC).
- \*4) The hand input cable and two air tubes are fixed on the surface of mechanical interface. And, all cables and hoses are fixed also in the cable outlet section.

\* For details, refer to Page 69, "2.5.6 Wiring and piping system diagram for hand".

Fig.2-27 : RV-4FR/7FR/13FR series wiring and piping for hand (SH01)

(4) RV-4FR/7FR/13FR series internal wiring and piping specification (SH02)

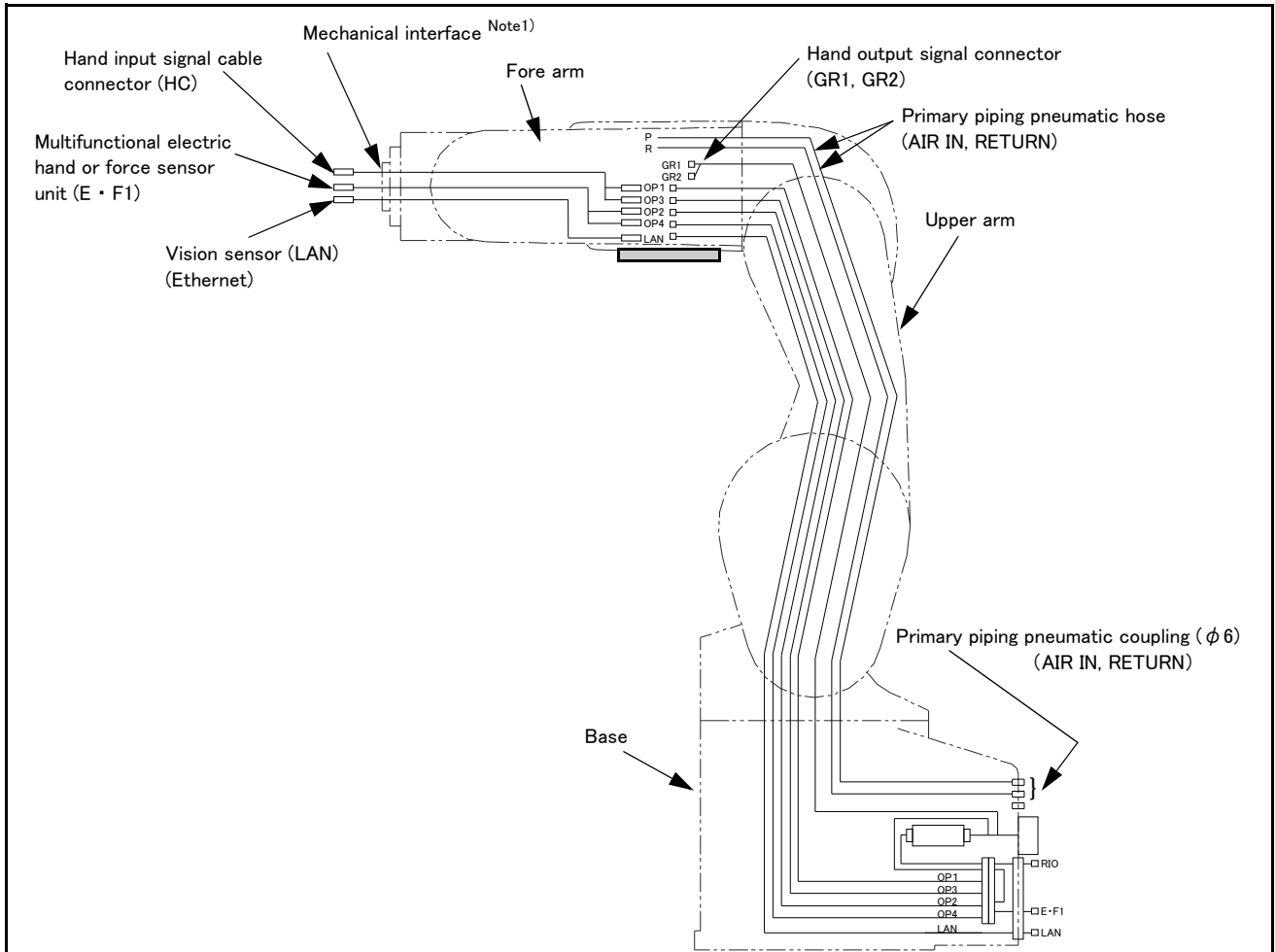

Note1) Mechanical interface (Front view)

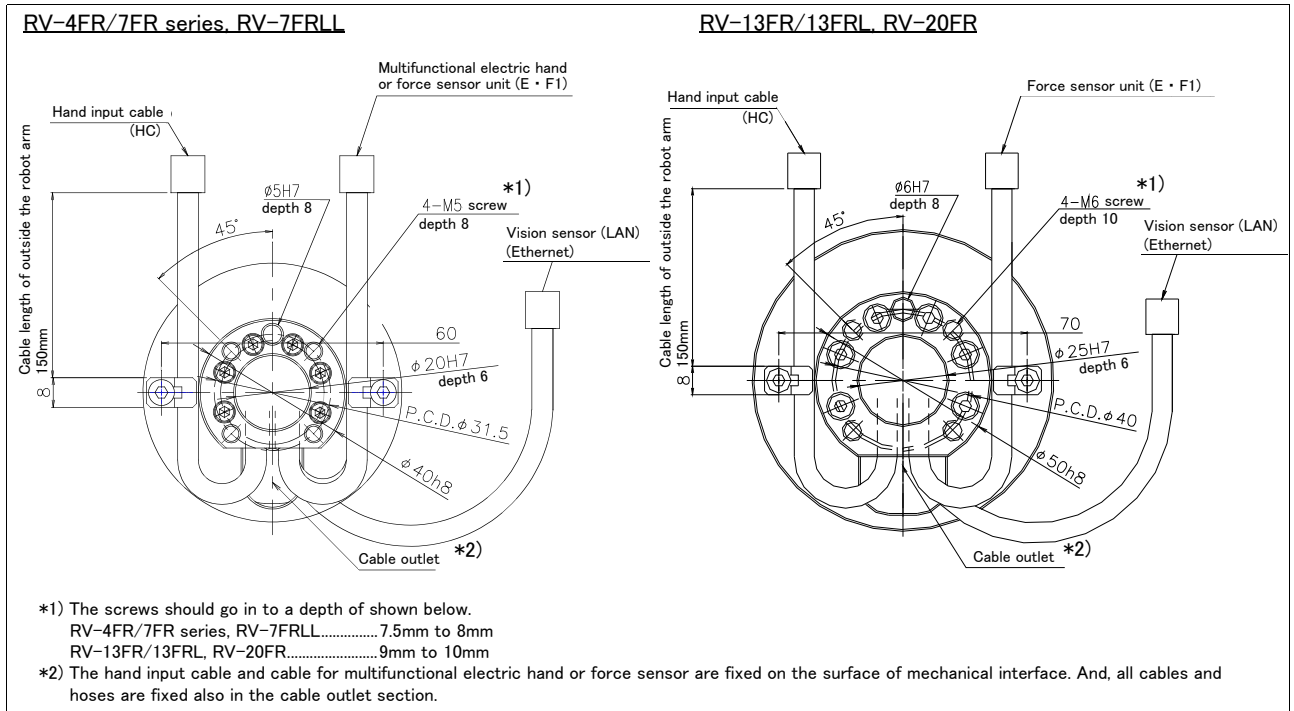

\* For details, refer to Page 69, "2.5.6 Wiring and piping system diagram for hand".

Fig.2-28 : RV-4FR/7FR/13FR series wiring and piping for hand (SH02)



(5) RV-4FR/7FR/13FR series internal wiring and piping specification (SH03)

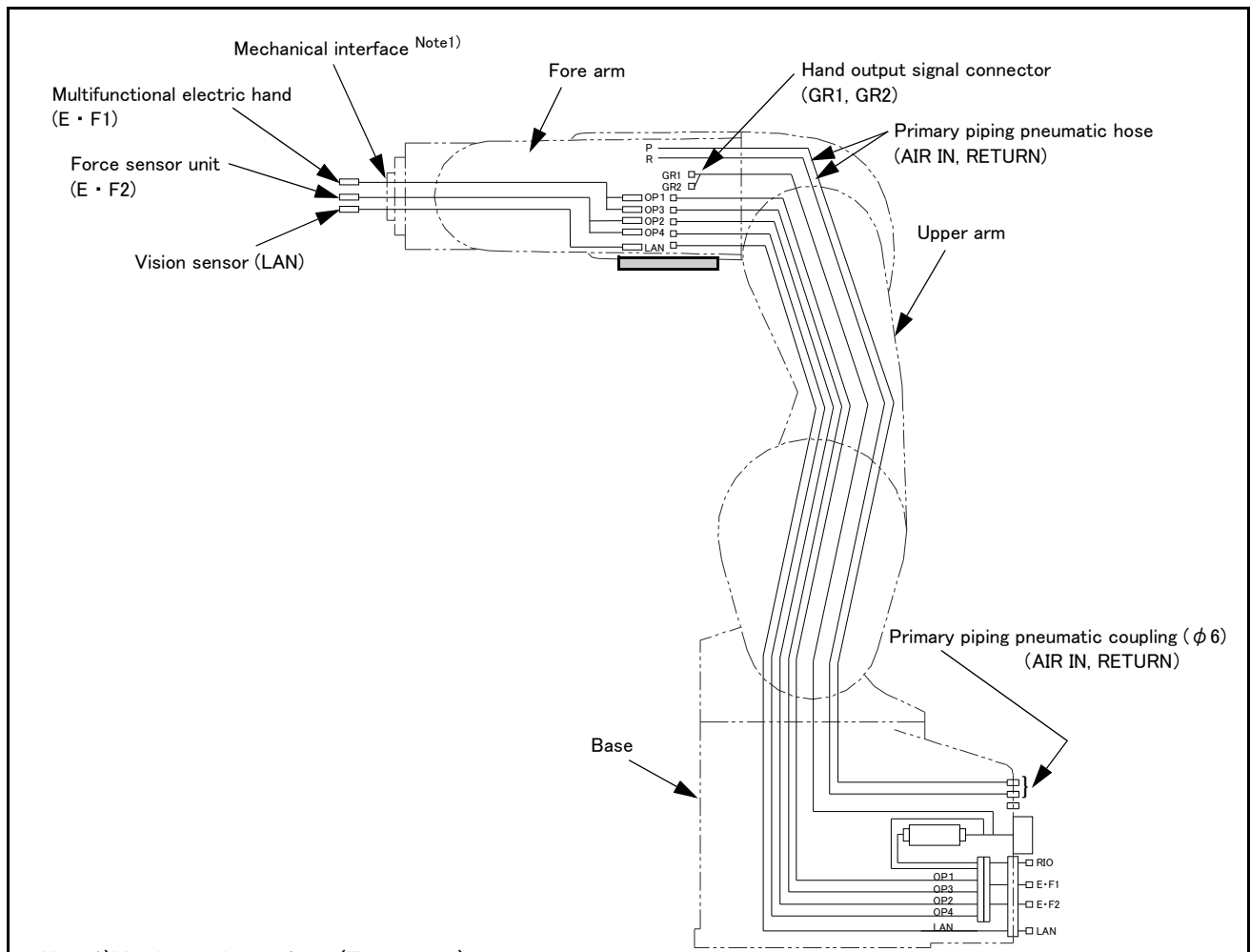

Note1) Mechanical interface (Front view)

RV-4FR/7FR series, RV-7FRLL

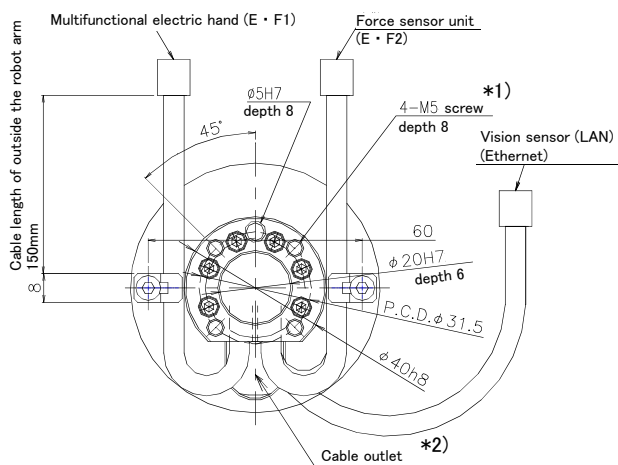

RV-13FR/13FRL, RV-20FR

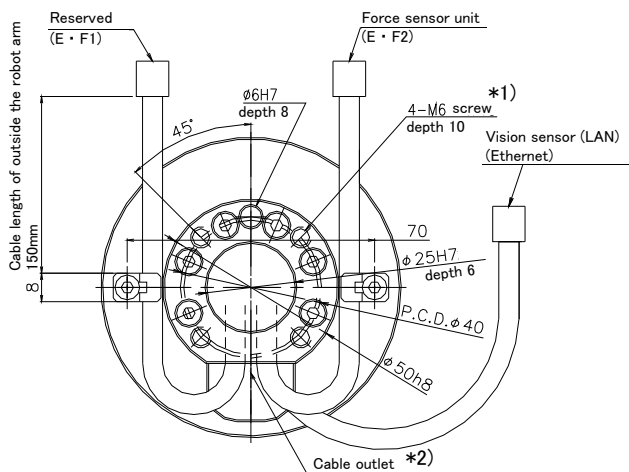

- \*1) The screws should go into a depth of shown below.  
 RV-4FR/7FR series, RV-7FRLL .....7.5mm to 8mm  
 RV-13FR/13FRL, RV-20FR .....9mm to 10mm
- \*2) The Multifunctional electric hand cable and force sensor cable are fixed on the surface of mechanical interface. And, all cables and hoses are fixed also in the cable outlet section.

\* For details, refer to Page 69, "2.5.6 Wiring and piping system diagram for hand".

Fig.2-29 : RV-4FR/7FR/13FR series wiring and piping for hand (SH03)

(6) RV-4FR/7FR/13FR series internal wiring and piping specification (SH04)

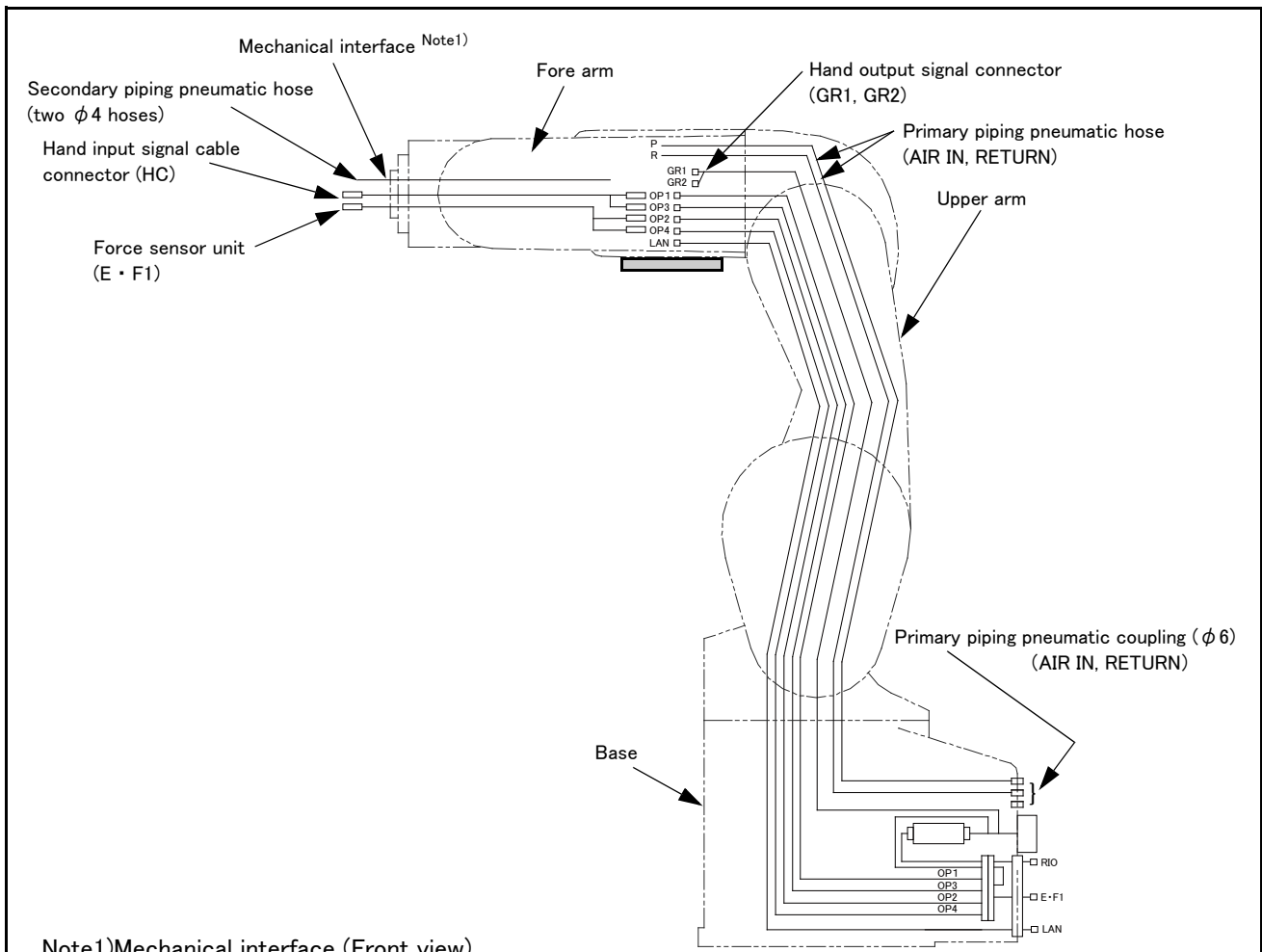

Note1) Mechanical interface (Front view)

RV-4FR/7FR series, RV-7FRLL

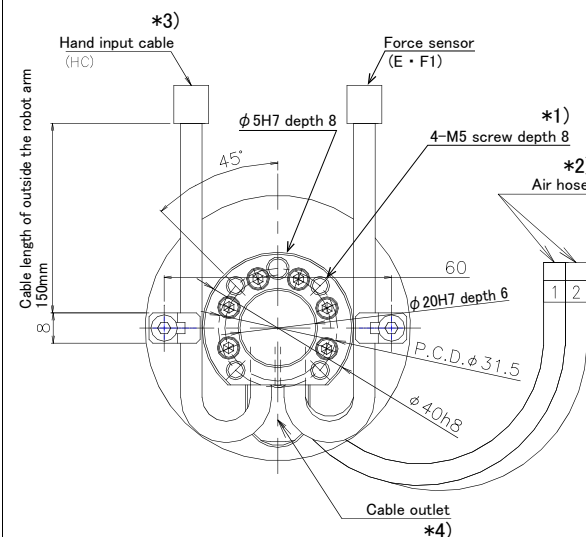

RV-13FR/13FRL, RV-20FR

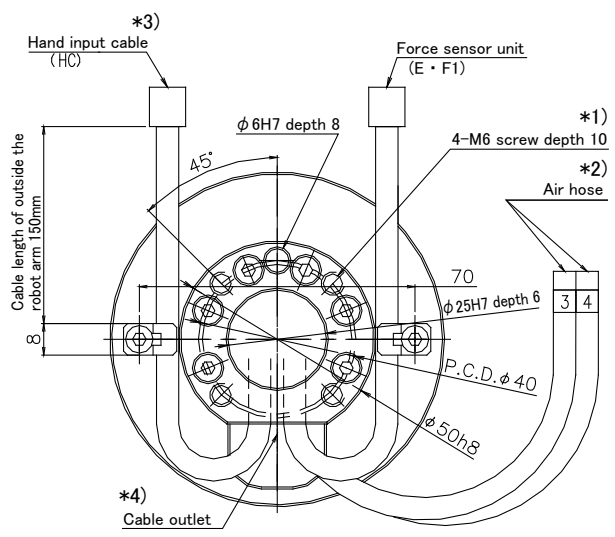

- \*1) The screws should go in to a depth of shown below.  
 RV-4FR/7FR series, RV-7FRLL.....7.5mm to 8mm  
 RV-13FR/13FRL, RV-20FR.....9mm to 10mm
- \*2) Two air tubes have numbered marking tube. Those lengths from the cable outlet are 300 mm.
- \*3) Refer to Fig. 2-37 for pin assignment of the hand input cable (HC).
- \*4) The hand input cable and force sensor cable are fixed on the surface of mechanical interface. And, all cables and hoses are fixed also in the cable outlet section.

\* For details, refer to Page 69, "2.5.6 Wiring and piping system diagram for hand".

Fig.2-30 : RV-4FR/7FR/13FR series wiring and piping for hand (SH04)

(7) RV-4FR/7FR/13FR series internal wiring and piping specification (SH05)

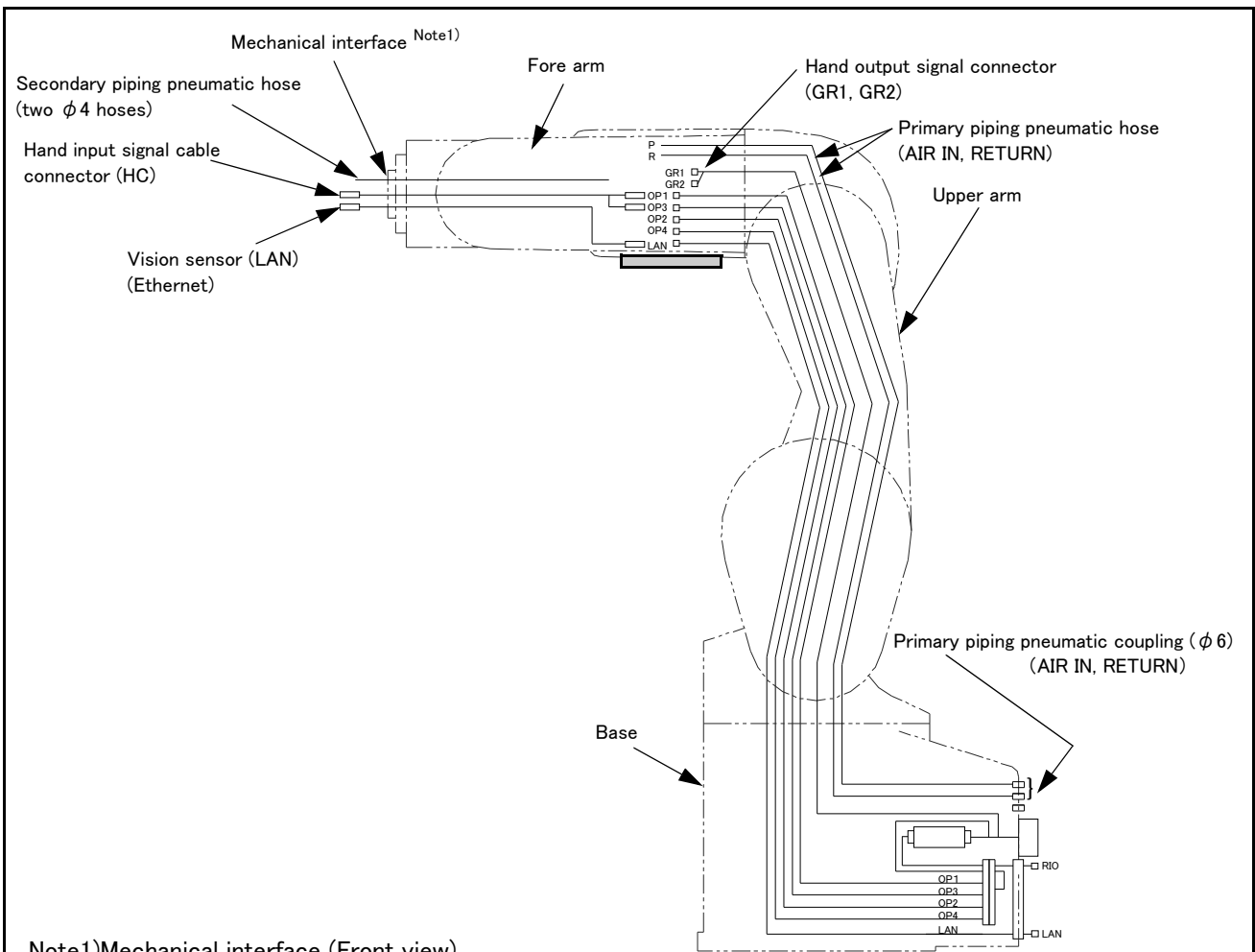

Note1) Mechanical interface (Front view)

RV-4FR/7FR series, RV-7FRLL

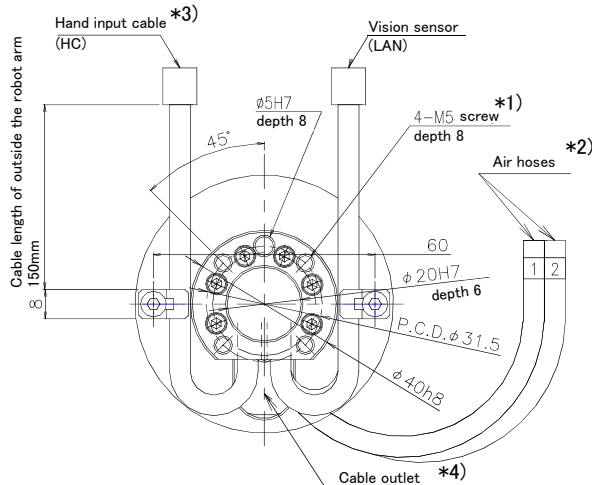

RV-13FR/13FRL, RV-20FR

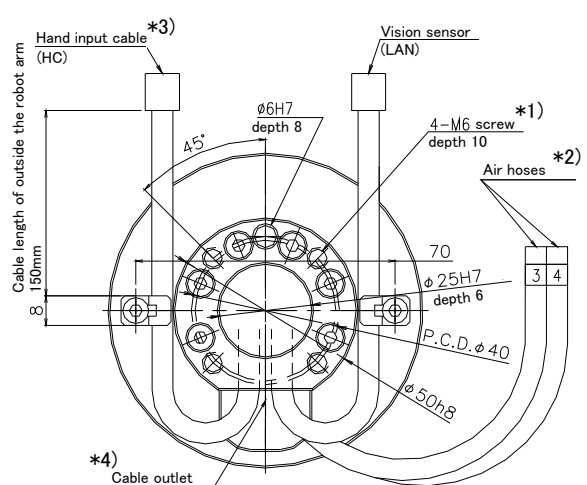

- \*1) The screws should go in to a depth of shown below.  
 RV-4FR/7FR series, RV-7FRLL.....7.5mm to 8mm  
 RV-13FR/13FRL, RV-20FR.....9mm to 10mm
- \*2) Two air tubes have numbered marking tube. Those lengths from the cable outlet are 300 mm.
- \*3) Refer to Fig. 2-38 for pin assignment of the hand input cable (HC).
- \*4) The hand input cable and force sensor cable are fixed on the surface of mechanical interface. And, all cables and hoses are fixed also in the cable outlet section.

\* For details, refer to Page 69, "2.5.6 Wiring and piping system diagram for hand".

Fig.2-31 : RV-4FR/7FR/13FR series wiring and piping for hand (SH05)

### 2.5.2 Internal air piping

#### (1) RV-2FR series

- 1) The robot has four  $\phi 4 \times 2.5$  urethane hoses from the pneumatic entrance on the base section to the forearm side. The hose end section has four coupling bridges for a  $\phi 4$  hose on both the base and forearm side
- 2) The robot can have up to two pneumatic valve sets on the side of base (optional). (Refer to [Page 89](#), "(4) Solenoid valve set (RV-2FR series)")

#### (2) RV-4FR/7FR/13FR series

##### ■ Standard/oilmist specifications

- 1) The robot has two  $\phi 6$  urethane hoses from the pneumatic entrance on the base section to the fore arm. One hose is the primary piping for the pneumatic equipment, and the other pipe is used for air exhaust.
- 2) The optional solenoid is provided with a maximum of eight couplings for the air hose. The diameter of the couplings are shown below.  
1F-VD0\*-02 (Sink type)/1F-VD0\*E-02 (Source type):  $\phi 4$   
1F-VD0\*-03 (Sink type)/1F-VD0\*E-03 (Source type):  $\phi 6$
- 3) The pneumatic inlet in the base section has a  $\phi 6$  pneumatic coupling bridge.
- 4) Refer to [Page 91](#), "(5) Solenoid valve set (RV-4FR/7FR/13FR series)" for details on the electronic valve set (optional).
- 5) The oil mist specification robot is equipped with the  $\phi 8$  coupling (AIR PURGE) for pressurizing of the inside on the base. Refer to [Page 37](#), "2.2.6 Protection specifications" for details of the dry air.

##### ■ Clean specifications

- 1) The primary piping is the same piping as the standard type.
- 2) The robot is equipped with the  $\phi 8$  coupling (VACUUM) for suctioning of the inside on the base. Connect the vacuum for suction (prepared by the customer) to the coupling.
- 3) Refer to [Page 39](#), "2.2.7 Clean specifications" for details of the vacuum for suction.
- 4) Supply clean air to the vacuum generator.

### 2.5.3 Internal wiring for the hand output cable

#### (1) RV-2FR series

- 1) The hand output cable extends from the connector of the base section to the back side of the base section. (AWG#24(0.2mm<sup>2</sup>) x 2: 8 cables) The cable terminals have connector bridges for four hand outputs. The connector names are GR1 to GR4.

#### (2) RV-4FR/7FR/13FR series

- 1) The hand output primary cable extends from the connector of the base section to the inside of the forearm. (AWG#24(0.2mm<sup>2</sup>) x 2 cores: 8 cables) The cable terminals have connector bridges for eight hand outputs. The connector names are GR1 and GR2.  
To extend the wiring to the outside of the arm, a separate cable (optional "hand output cable 1F-GR35S-02" ) is required.

## 2.5.4 Internal wiring for the hand input cable

### (1) RV-2FR series

The hand check input cable is wired to four points on the forearm side from the base. To extend the wiring to the outside of the arm, a separate cable (optional "hand input cable "1S-HC30C-11" is recommended) is required.

Note) Refer to [Page 95](#), "(6) Hand input cable (RV-2FR series)" for wiring diagram, and always should connect the 100-ohm resistance to B1 and B2 terminals .

### (2) RV-4FR/7FR/13FR series

1) The hand input cable extends from the connector of the base section to the inside of the forearm.

(AWG#24(0.2mm<sup>2</sup>) for eight points) The cable terminals have connector bridges for eight hand inputs. The connector names are OP1 and OP3.

2) The hand check signal of the pneumatic hand is input by connecting this connector.

To extend the wiring to the outside of the arm, a separate cable (optional "hand input cable "1F-HC35S-02") is required.

## 2.5.5 Ethernet cable, option wiring cable

### (1) RV-4FR/7FR/13FR series

Ethernet cables, eight option signal cables, and four power supply cables internally run from the robot's base section up to the forearm area. The allowable current of each cable is 1 A.

These cables can be also pulled out from the underneath of the forearm or from the side of the base area by using options. (Options "Forearm external wiring set" and "Base external wiring set".)

Table 2-13 : Ethernet cable specification

Item	Specification
Communication speed	100BASE-TX
Size	AWG #26 (0.13mm <sup>2</sup> ) x four pair (total eight cores)
Externality of insulator	Approx. 0.98 mm

2.5.6 Wiring and piping system diagram for hand

Shows the system configuration of wiring and piping.

(1) RV-2FR series

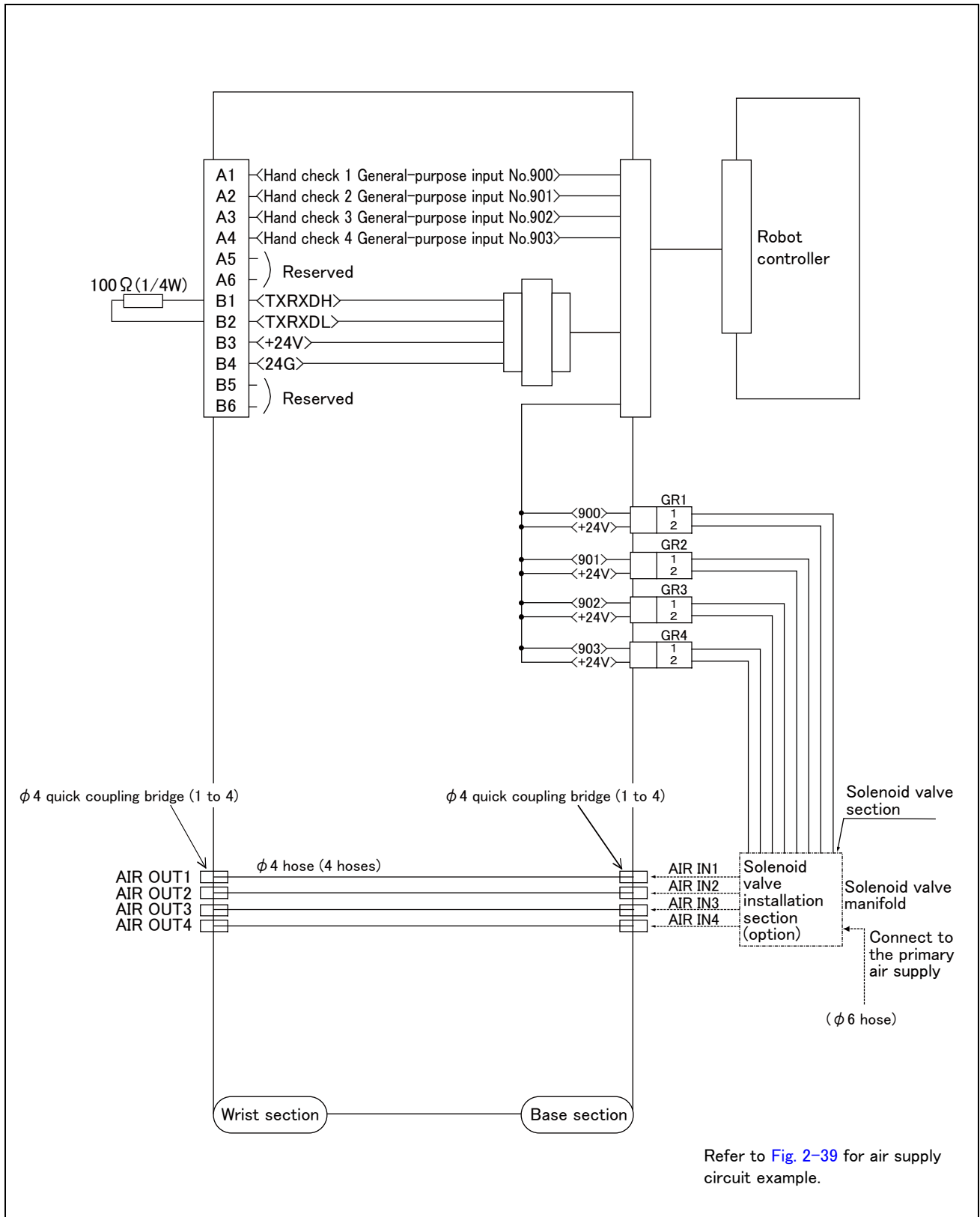

Fig.2-32 : Wiring and piping system diagram for hand and example the solenoid valve installation: RV-2FR series

(2) RV-4FR/7FR/13FR series standard specification (with no internal wiring and piping)

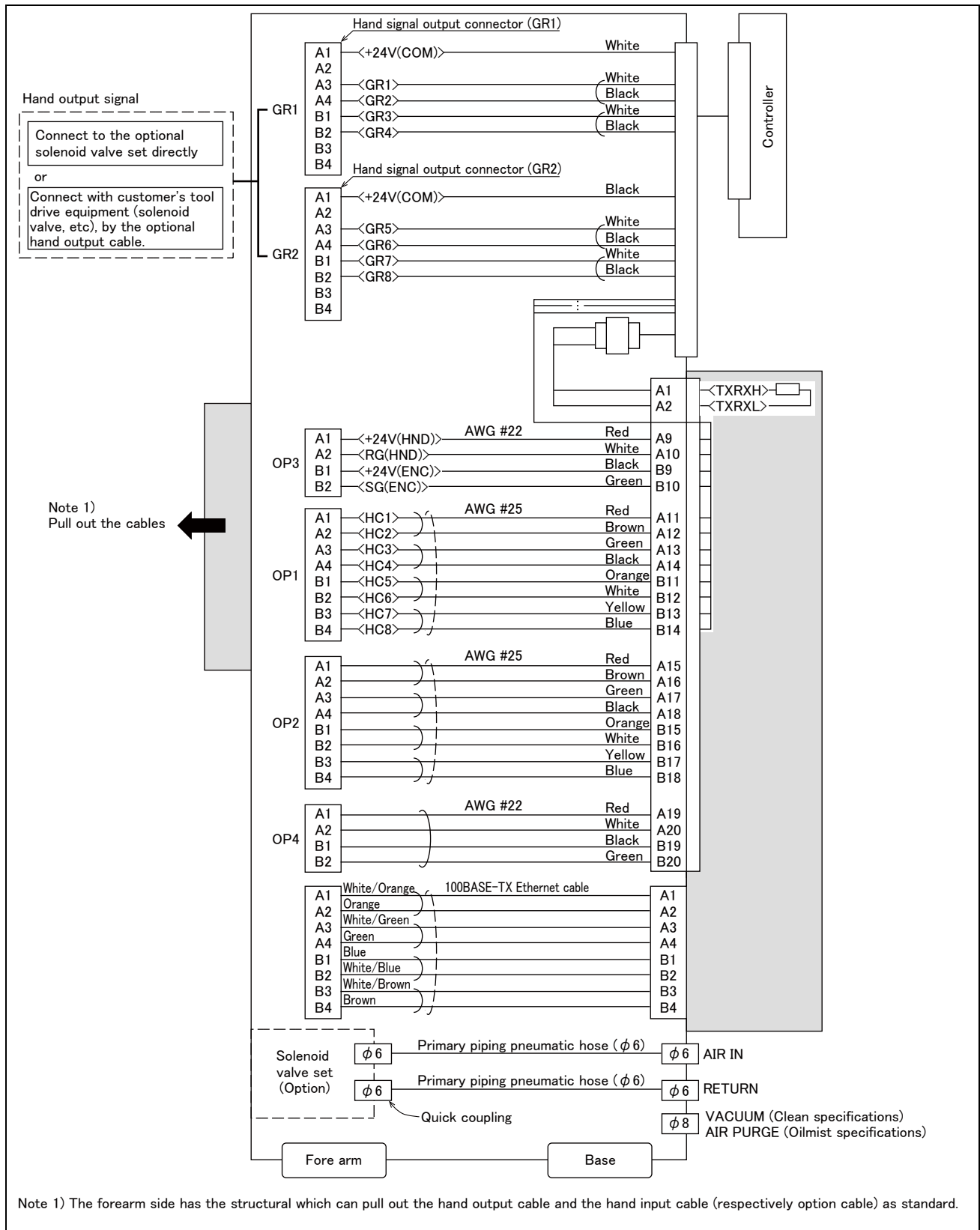

Fig.2-33 : Wiring and piping system diagram for hand and example the solenoid valve installation: RV-4FR/7FR/13FR series standard

(3) RV-4FR/7FR/13FR series internal wiring and piping specification (SH01)

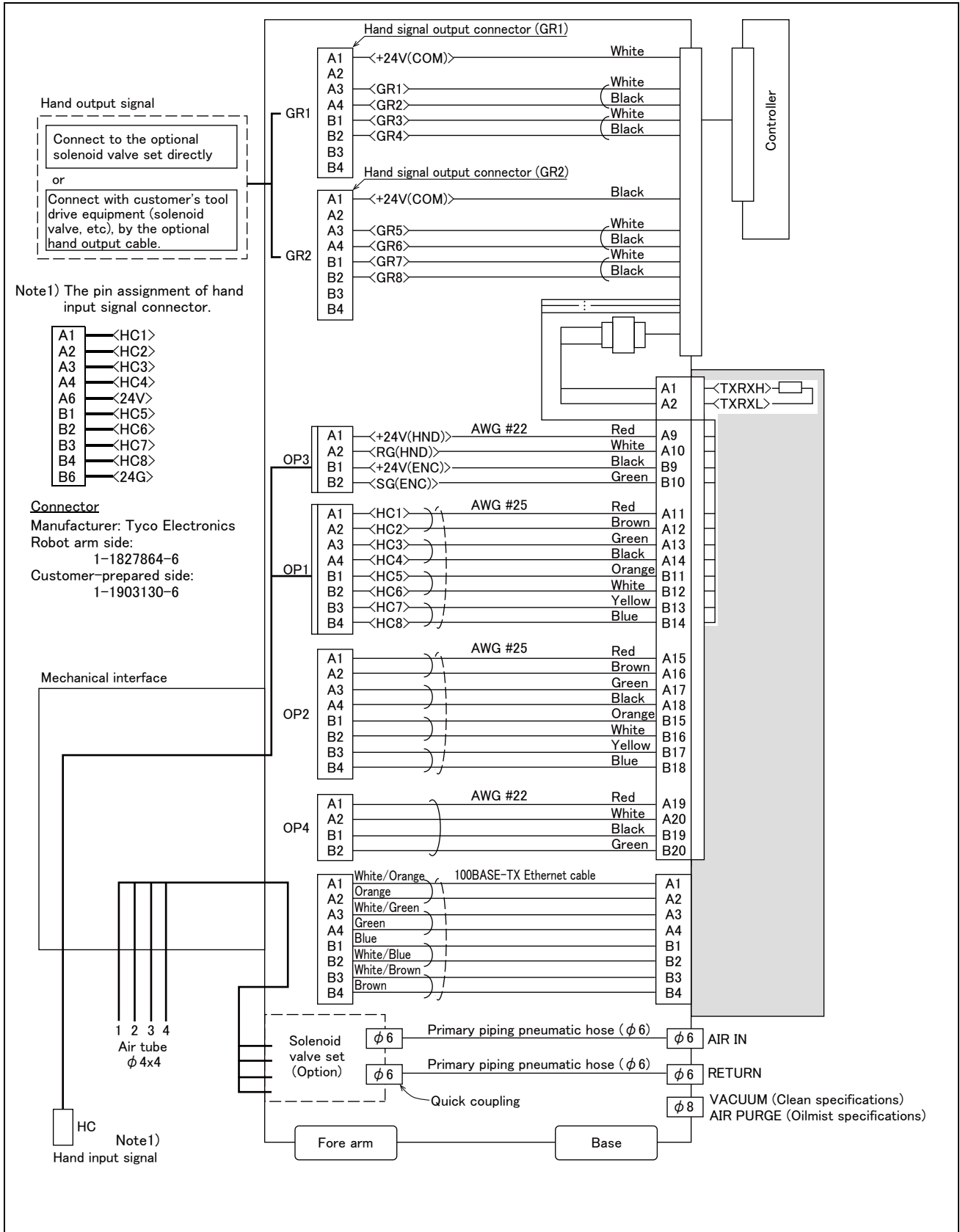

Fig.2-34 : Wiring and piping system diagram for hand and example the solenoid valve installation: RV-4FR/7FR/13FR series SH01



(4) RV-4FR/7FR/13FR series internal wiring and piping specification (SH02)

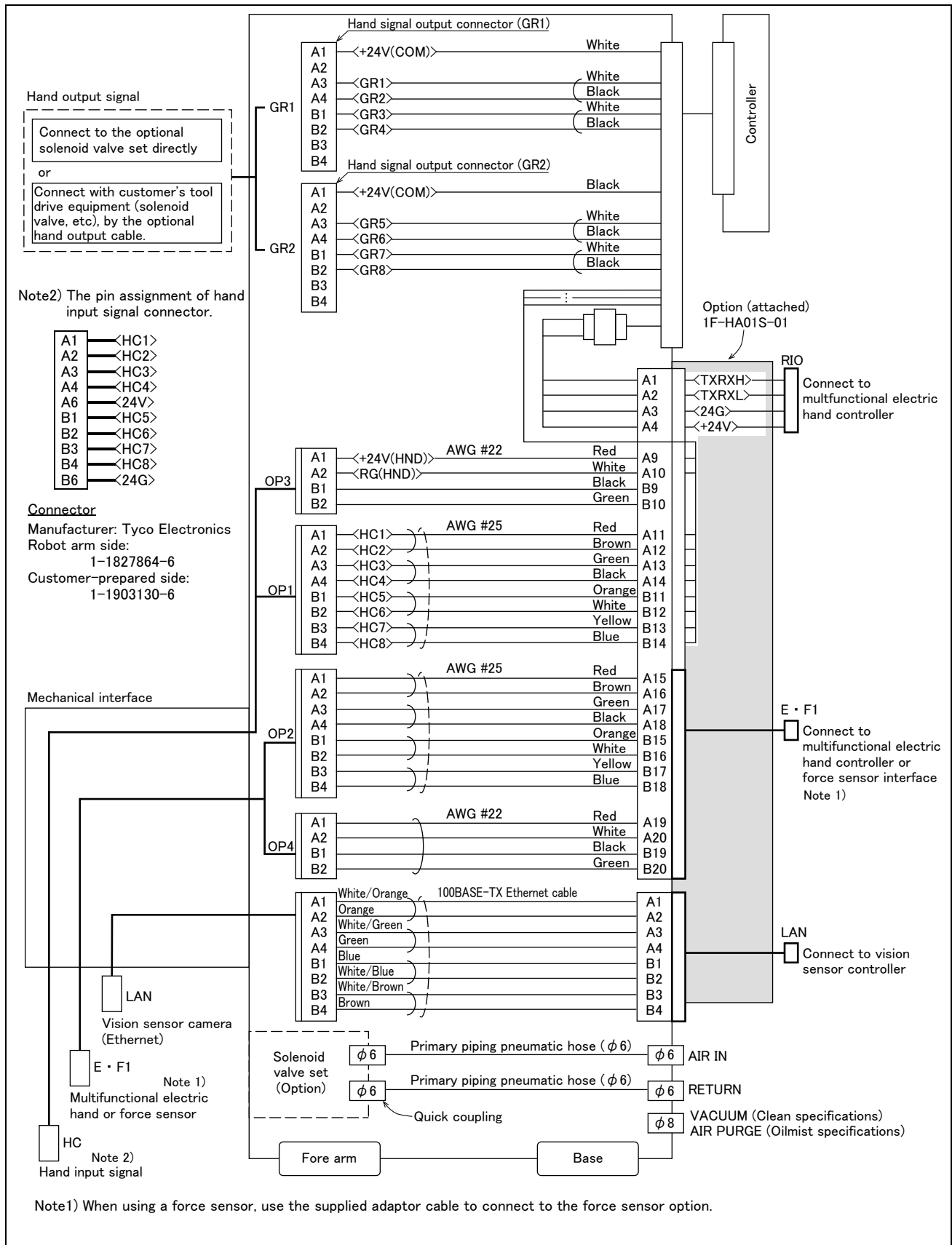

Fig.2-35 : Wiring and piping system diagram for hand and example the solenoid valve installation: RV-4FR/7FR/13FR series SH02

(5) RV-4FR/7FR/13FR series internal wiring and piping specification (SH03)

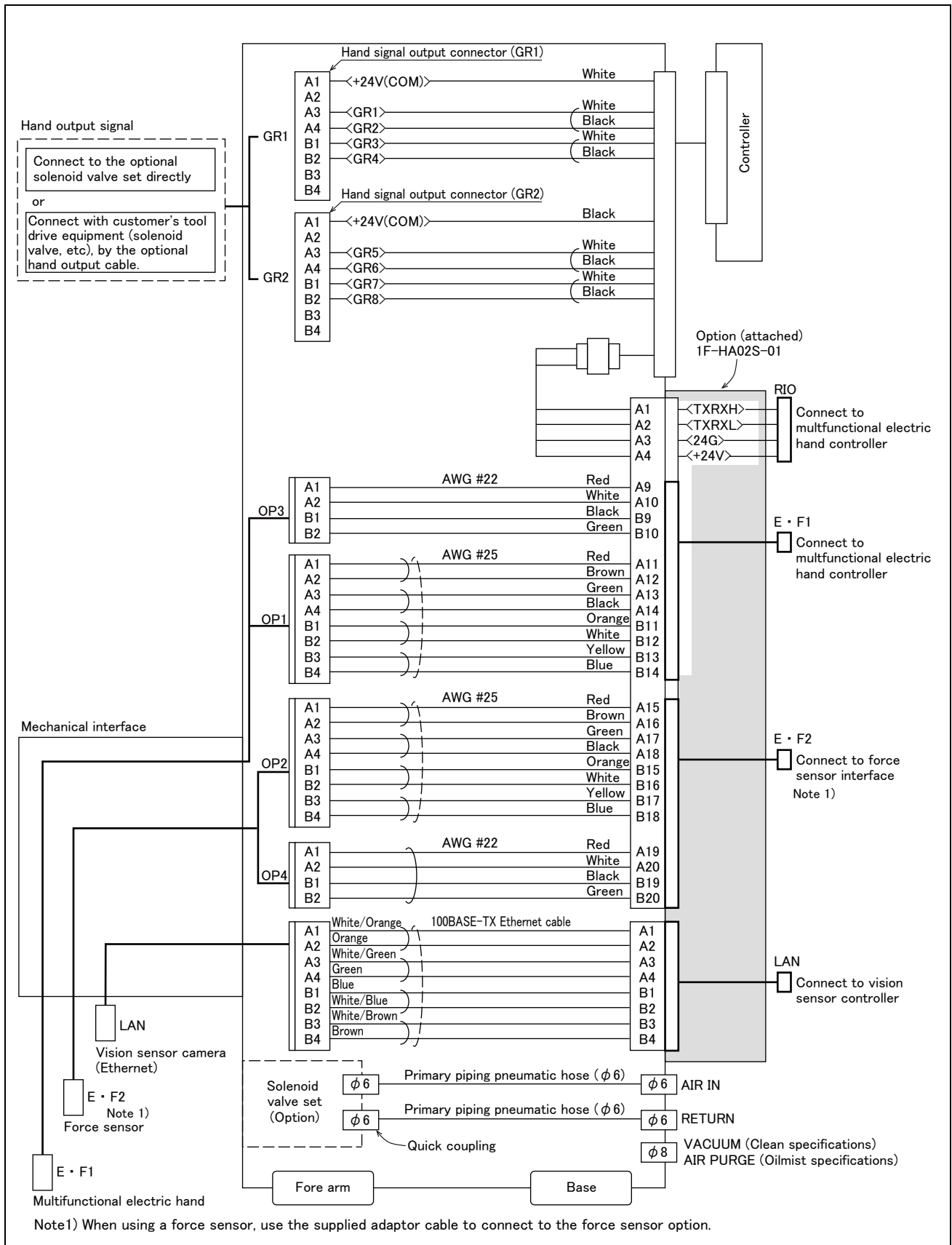

Fig.2-36 : Wiring and piping system diagram for hand and example the solenoid valve installation: RV-4FR/7FR/13FR series SH03

(6) RV-4FR/7FR/13FR series internal wiring and piping specification (SH04)

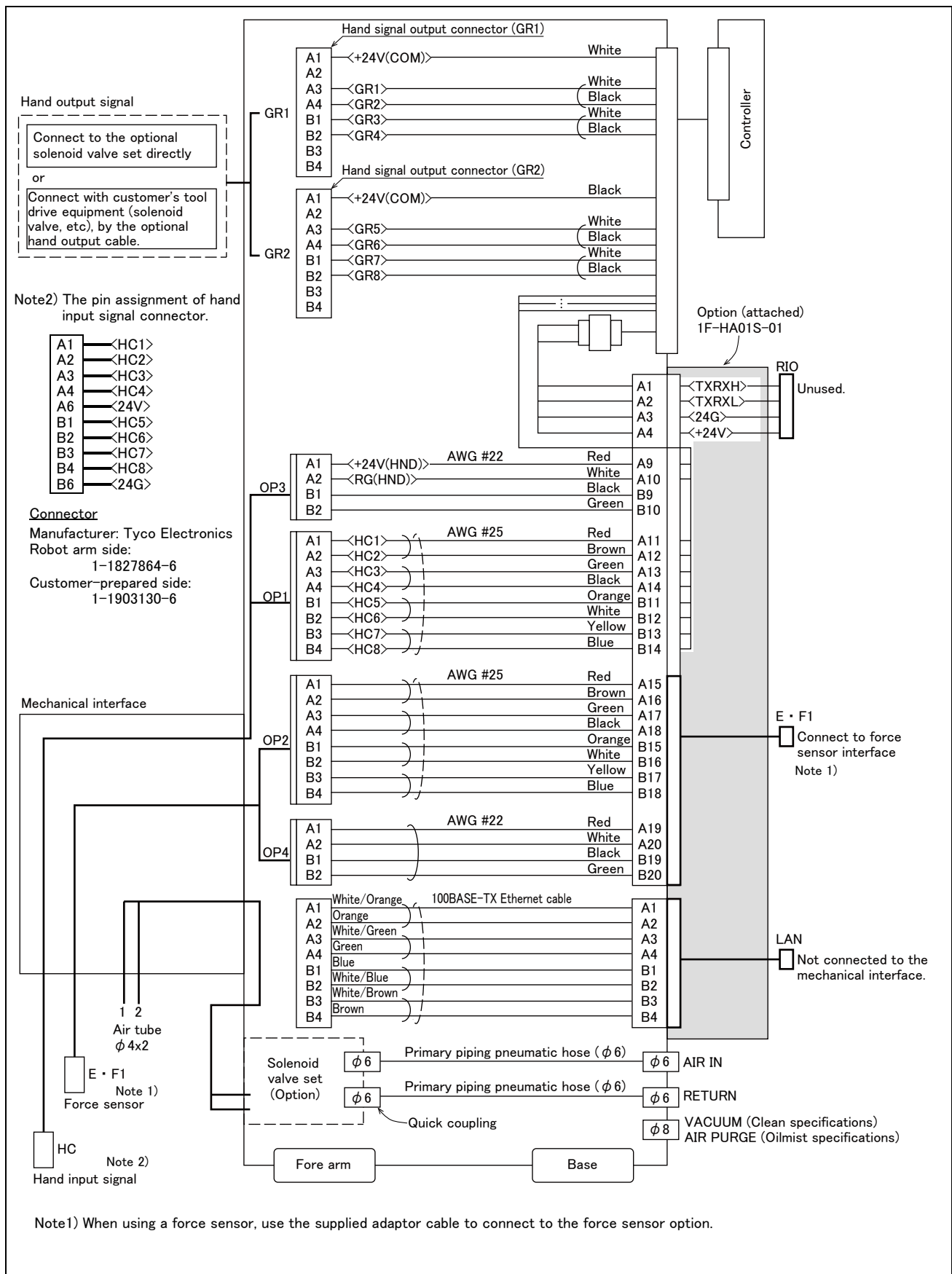

Fig.2-37 : Wiring and piping system diagram for hand and example the solenoid valve installation: RV-4FR/7FR/13FR series SH04

(7) RV-4FR/7FR/13FR series internal wiring and piping specification (SH05)

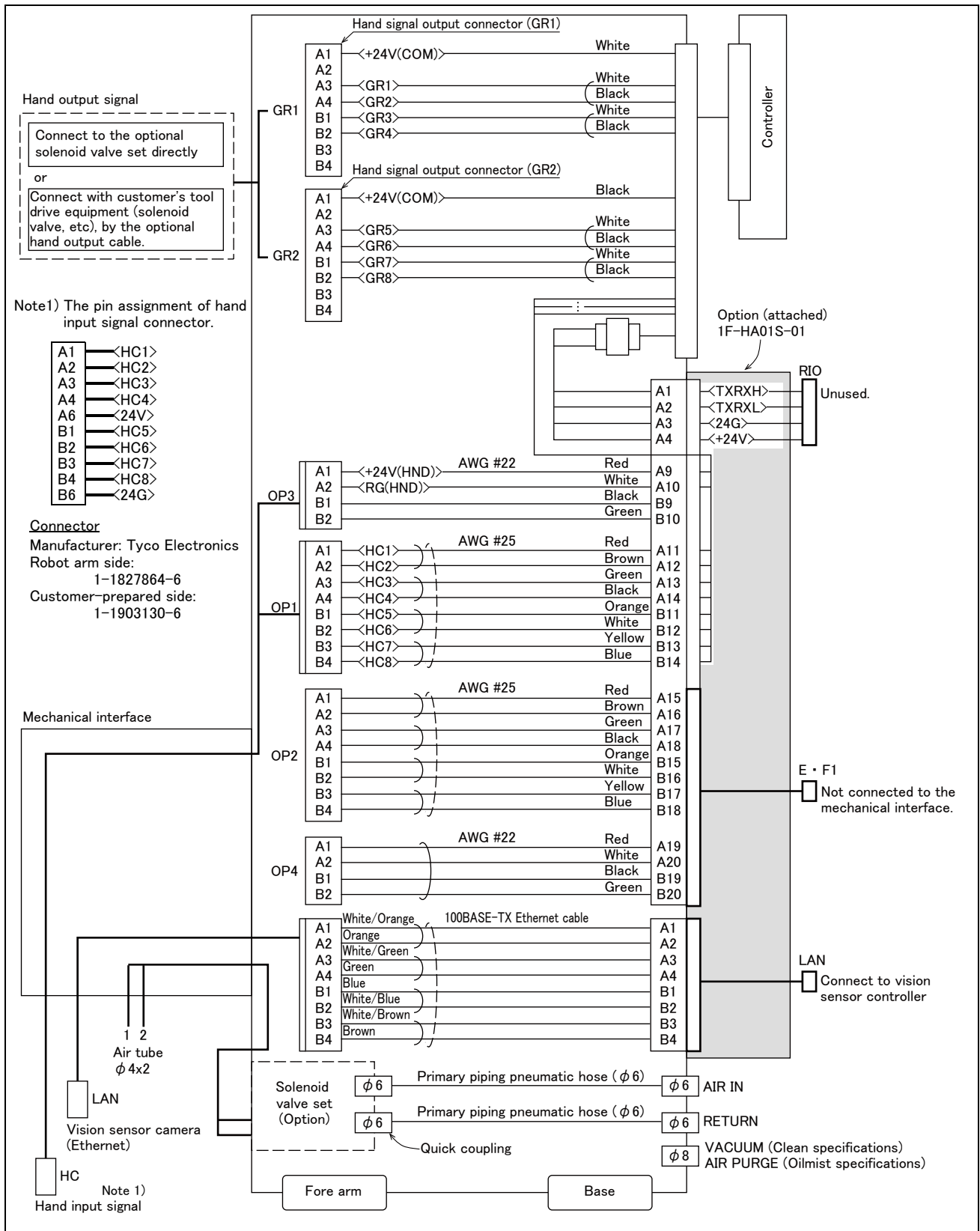

Fig.2-38 : Wiring and piping system diagram for hand and example the solenoid valve installation: RV-4FR/7FR/13FR series SH05

2.5.7 Electrical specifications of hand input/output

Table 2-14 : Electrical specifications of input circuit

Item	Specifications	Internal circuit	
Type	DC input	<p>&lt;Sink type&gt;</p>  <p>&lt;Source type&gt;</p>  <p>* Hand input RV-2FR series: HCn=HC1 to HC4 Other models: HCn=HC1 to HC8</p>	
No. of input points	8		
Insulation method	Photo-coupler insulation		
Rated input voltage	24VDC		
Rated input current	approx. 7mA		
Working voltage range	DC10.2 to 26.4V (ripple rate within 5%)		
ON voltage/ON current	8VDC or more/2mA or more		
OFF voltage/OFF current	4VDC or less/1mA or less		
Input resistance	Approx. 3.3kΩ		
Response time	OFF-ON		10ms or less (DC24V)
	ON-OFF		10ms or less (DC24V)

Table 2-15 : Electrical specifications of output circuit

Item	Specification	Internal circuit	
Type	Transistor output	<p>&lt;Sink type&gt;</p>  <p>&lt;Source type&gt;</p>  <p>* Hand output RV-2FR series: GRn=GR1 to GR4 Other models: GRn=GR1 to GR8</p>	
No. of output points	8		
Insulation method	Digital isolator		
Rated load voltage	DC24V		
Rated load voltage range	DC21.6 to 26.4VDC		
Max. current load	0.1A/ 1 point (100%)		
Current leak with power OFF	0.1mA or less		
Maximum voltage drop with power ON	DC0.9V(TYP.)		
Response time	OFF-ON		2ms or less (hardware response time)
	ON-OFF		2ms or less (resistance load) (hardware response time)
Protects	Protects the over-current (0.9A)		

### 2.5.8 Air supply circuit example for the hand

An example of pneumatic supply circuitry for the hand is shown below.

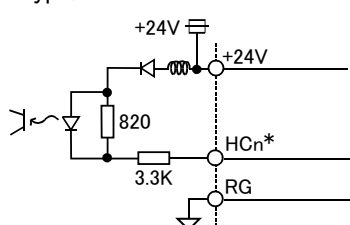
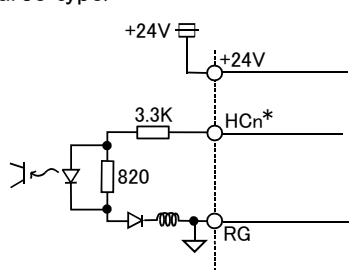
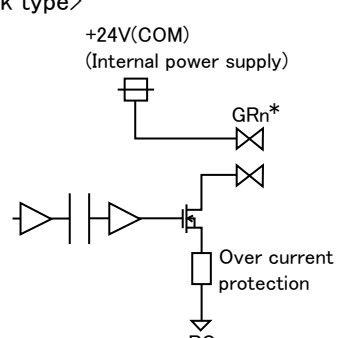
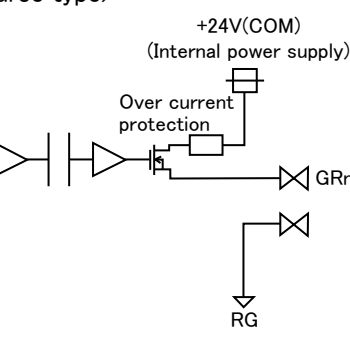
- 1) Make sure that a surge voltage protection circuit such as a diode is connected to the solenoid coil in parallel.
- 2) When the factory pneumatic pressure drops, as a result of the hand clamp strength weakening, there can be damage to the work. To prevent it, install a pressure switch to the source of the air as shown in Fig. 2-39 and use the circuit described so that the robot stops when pressure drops. Use a hand with a spring-pressure clamp, or a mechanical lock-type hand, that can be used in cases where the pressure switch becomes damaged.
- 3) The optional hand and solenoid valve are of an oilless type. If they are used, don't use any lubricator.
- 4) Supply clean air to the vacuum generation valve when you use clean specifications robot.
- 5) If the air supply temperature (primary piping) used for the tool etc. is lower than ambient air temperature, the dew condensation may occur on the coupling or the hose surface.

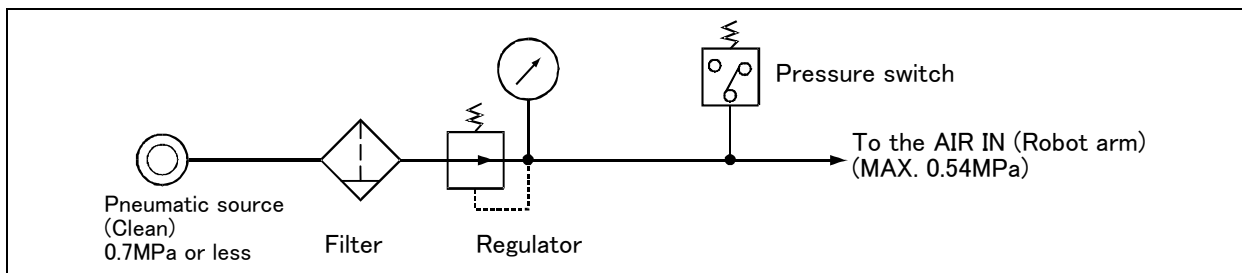

Fig.2-39 : Air supply circuit example for the hand

### 2.5.9 About the Installation of Tooling Wiring and Piping

The customer is required to provide tooling wiring, piping and metal fixtures.

Screw holes are provided on the robot arm for the installation of tooling wiring, piping and metal fixtures. (Refer to the Page 41, "2.4 Outside dimensions • Operating range diagram".)

The length of wiring and piping and the installation position on the robot must be adjusted according to the work to be done by the robot. Please use the following example as reference.

#### <Precautions>

- A hand input cable and a hand curl cable are available as optional accessories for your convenience.
- After performing wiring and piping to the robot, operate the robot at low speed to make sure that each part does not interfere with the robot arm and the peripheral devices.
- Please be aware that dust may be generated from friction if wires and pipes come into contact with the robot arm when using it according to the clean specifications.
- If you install metal fixtures and a solenoid valve using the screw holes on the No.2 arm portion, add the mass of the metal fixtures and the solenoid valve to mass of a hand and set to parameter: HNDDAT. Moreover, Fix the parts, such as a solenoid valve, firmly to prevent the parts getting shaky during operation of a robot.

## 2.6 Options

### ■ What are options?

There are a variety of options for the robot designed to make the setting up process easier for customer needs. customer installation is required for the options.

(1) Machine cable (replacement)

- Order type:     ● Fixed type..... 1F- □□ UCBL-41
- Flexed type..... 1F- □□ LUCBL-41

Note) The numbers in the boxes □□ refer the length.

■ Outline



This cable is used for extending or shortening the distance between the controller and the robot.  
 A fixed type and flexible type are available.  
 Exchanges with the machine cable attached in the standards.

■ Configuration

Table 2-16 : Configuration equipment and types

Part name	Type <sup>Note1)</sup>	Qty.	Mass (kg) <sup>Note2)</sup>	Remarks
Machine cable (replacement) fixed type	1F- □□ UCBL-41	1 cable	2.6 (2m) 9 (10m) 13 (15m) 17 (20m)	2m, 10m, 15m or 20m each
Machine cable (replacement) flexed type	1F- □□ LUCBL-41	1 cable	11 (10m) 16 (15m) 21 (20m)	10m, 15m or 20m each
Nylon clamp	NK-24N	2 pcs.	-	
Silicon rubber		2 pcs.	-	

Note1) The numbers in the boxes □□ refer the length.

Note2) Mass indicates one set.

■ Specifications

The specifications for the fixed type cables are the same as those for standard cables. Shows usage conditions for flexed type cables in [Table 2-17](#).

Table 2-17 : Conditions for the flexed type cables

Item	Specifications
Minimum flexed radius	100mm or more
Cableveyor, etc., occupation rate	50% or less
Maximum movement speed	2,000mm/s or less
Guidance of life count	7.5 million times (With silicone grease coating)
Environmental proof	IP54
Cable configuration	φ 8.9x3, φ 6.5x6, φ 6.2x1, φ 6x6

[Caution] The guidance of life count may greatly differ according to the usage state items related to [Table 2-17](#) and to the amount of silicon grease applied in the cableveyor.

Recommendation grease: G-501 (Supplier: Shin-Etsu Chemical Co., Ltd.)

[Caution] This option can be installed on clean-type, but its cleanliness is not under warranty.

[Caution] When a cableveyor is used, partitions are required to avoid overlapping or riding up of the cables. Also, adjust the cable length to eliminate tension or excessive looseness, and fix it securely.



■ Cable configuration

The configuration of the flexible cable is shown in [Table 2-18](#). Refer to this table when selecting the cable vendor.

Table 2-18 : Cable configuration (Flexed type)

Item	Motor signal cable		Motor power cable	
	AWG #24 (0.2mm <sup>2</sup> )-4P	AWG #28 (0.08mm <sup>2</sup> )-4P	AWG #16 (1.25mm <sup>2</sup> )-4C	AWG #18 (0.75mm <sup>2</sup> )-3C
No. of cores	Approx. $\phi$ 6mm	Approx. $\phi$ 6.2mm	Approx. $\phi$ 8.9mm	Approx. $\phi$ 6.5mm
Finish dimensions	6	1	3	6
No. of cables used	7		9	
No. in total				

■ Fixing the flexible cable

- (1) Connect the connector to the robot arm.

The connection method to a robot arm is the same as a standard machine cable. Please refer to the separate "Instruction Manual/ROBOT ARM SETUP & MAINTENANCE" and connect.

- (2) Wind the silicon rubber around the cable at a position 300 to 400 mm from the side of robot arm and extension section as shown below, and fix with the nylon clamp to protect the cable from external stress.

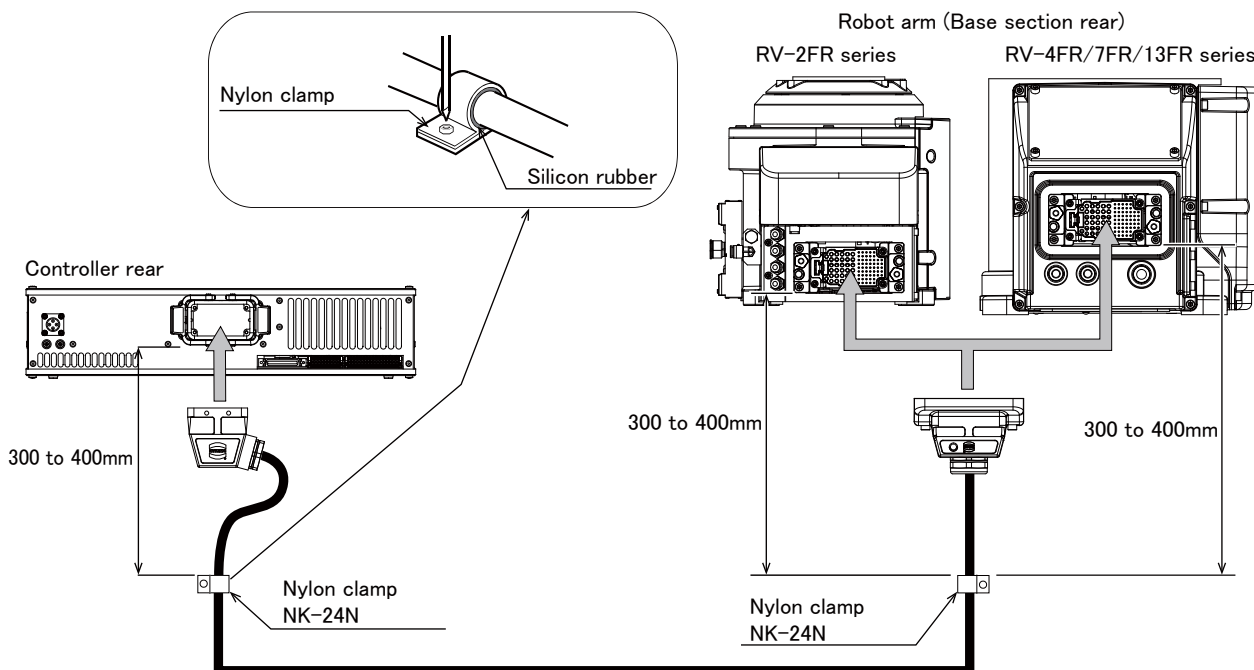

The bend size of cables are as follows.

<RV-2FR series>

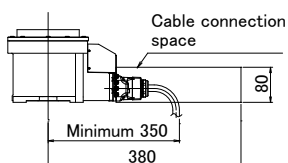

<RV-4FR series>

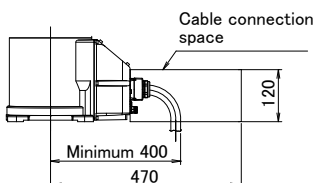

<RV-7FR series>

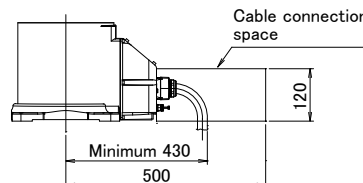

<RV-7FRLL, RV-13FR/13FRL, RV-20FR>

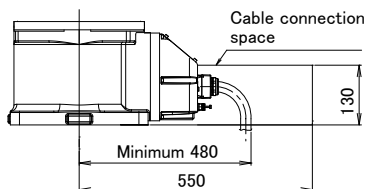

Fig.2-40 : Fixing the flexible cable

## (2) Stopper for changing the operating range (RV-2FR series)

- Order type J1 axis: 1S-DH-11J1  
J2 axis: 1S-DH-11J2  
J3 axis: 1S-DH-11J3

## ■ Outline



The operating range of J1, J2 or J3 axis is limited by the robot arm's mechanical stopper and the controller parameters.

If the axis could interfere with the peripheral devices, etc., and the operating range need to be limited, use this.

## ■ Configuration

Table 2-19 : Configuration devices

Part name	Type	Qty.	Mass(kg)	Remarks
Stopper for changing the operating range	1S-DH-11J1	1 pcs.	0.5	Variable stopper block: One set, Fixing stopper: Two blocks, Installation screw (M5 x 20): Six screws
	1S-DH-11J2	1 pcs.	0.1	Stopper A: One block, Stopper B: One block, Installation screw (M4 x 10): Four screws
	1S-DH-11J3	1 pcs.	0.1	Stopper: One set, Installation screw (M4 x 10): One screw (M4 x 25): One screw

## ■ Specifications

Table 2-20 : Specifications

Axis		Standard	Changeable angle <sup>Note1)</sup>
J1	+ side	+240 degree	Change to +210(+217), +150(+155) or +90 (+93) degree are possible.
	- side	-240 degree	Change to -210(-217), -150(-155) or -90 (-93) degree are possible.
J2	+ side	+120 degree	Change to +30(+33) degree is possible.
	- side	-120 degree (RV-2FR/2FRB)	Change to -30(-33) degree is possible.
		-117 degree (RV-2FRL/2FRLB)	
J3	+ side	+160 degree	Nothing
	- side	0 degree	Change to +70(+69) degree is possible.

Note 1) The number in bracket ( ) shows the mechanical stopper's installation position.

Note 2) Change of the operating range has limitation of combination. Change the operating range to +/-150, +/-90, +210 to -90, +90 to -210, +150 to -90 or +90 to -150 degree are possible.

Table 2-21 : Operating range change combination of the J1 axis.

	+ side	+210	+150	+90
- side				
-210		x	x	○
-150		x	○	○
-90		○	○	○

○ : Possible. x : Impossible.

The operating range change stopper installs in the position (near 0 degree) that the J1 axis has turned to the front.

Note 3) Change the operating range to +70 to +160 degree is possible.

- (1) The changeable angle shown in Table 2-20 indicates the operation range by the software. The changeable angle of + side and - side can be changed independently.
- (2) The operating range is changed with robot arm settings (installation of the stopper) and parameter settings. Refer to the separate "Instruction Manual/ROBOT ARM SETUP & MAINTENANCE" and "Instruction Manual/Detailed Explanation of Functions and Operations" for details.

(3) J1 axis operating range change (RV-4FR/7FR/13FR series)

- Order type   RV-4FR series: 1F-DH-03  
                   RV-7FR series: 1F-DH-04  
                   RV-13FR series: 1F-DH-05J1

■ Outline



The operating range of J1 axis is limited by the robot arm's mechanical stopper and the controller parameters.  
 If the axis could interfere with the peripheral devices, etc., and the operating range need to be limited, use this.

■ Configuration

(1) RV-4FR series (1F-DH-03)

Table 2-22 : Configuration devices (RV-4FR series)

No.	Part name	Qty.	Mass (kg)	Remarks
<1>	Stopper plate	2	1.1	One piece each for + side/- side
<2>	Fixing block A	2		One piece each for + side/- side
<3>	Fixing block B	1		+ side
<4>	Fixing block C	1		- side
<5>	Variable stopper block	2		One piece each for + side/- side
<6>	Screw (M10x20)	2		Use for mechanical stopper screw A and B
<7>	Screw (M6x25)	2		For fixing
<8>	Screw (M6x20)	16		For fixing

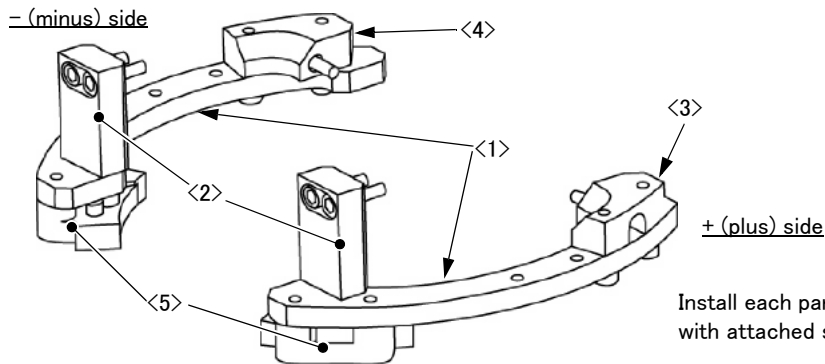

Install each parts to the upper arm lower part with attached screw.

Table 2-23 : Changeable angle (RV-4FR series)

Item	Standard	Changeable angle (combination of + side/- side) (Unit: Degree)			
+ (plus) side	+240	+30	+73	+103	+146
Variable stopper block angle	-	+33	+76	+106	+149
Variable stopper block position <sup>Note1)</sup>	-	(a)	(b)	(a)	(b)
Mechanical stopper screw A <sup>Note2)</sup>	-	Use		Disuse <sup>Note3)</sup>	
Parameter (MEJAR) setting value	+240	+30	+73	+103	+146
- (minus) side	-240	-30	-73	-103	-146
Variable stopper block angle	-	-33	-76	-106	-149
Variable stopper block position <sup>Note1)</sup>	-	(d)	(c)	(d)	(c)
Mechanical stopper screw B <sup>Note2)</sup>	-	Use		Disuse <sup>Note3)</sup>	
Parameter (MEJAR) setting value	-240	-30	-73	-103	-146

Note1) Symbol: “(a)” – “(d)” are related with the symbol of Page 86 “Fig. 2-41: Installation image of J1axis operating range change option (RV-4FR/7FR series)”.

Note2) In the table, it means that “Disuse” does not install the screw, and “Use” does install the screw.

Note3) Mechanical stopper screw which is either one of the two is always necessary. For this reason, the combination enclosed by the thick line of the square in the table (both of + (plus) side and - (minus) side are 103 or 146) cannot be used.

Example) It cannot be used that set +146 as the plus side and set -103 as the minus side simultaneously. The other combination can be set up.

- 1) The changeable angle of RV-4FR series is shown in Table 2-23. The changeable angle shown in Table 2-23 indicates the operation range by the software.  
The limit by the mechanical stopper is positioned three degrees outward from that angle, so take care when designing the layout.
- 2) The changeable angle can be set independently on the + (plus) side/ - (minus) side, within the condition shown in Table 2-23.
- 3) The operating range is changed with robot arm settings and parameter settings. Refer to the separate “Instruction Manual/ROBOT ARM SETUP & MAINTENANCE” or “Instruction Manual/Detailed Explanation of Functions and Operations” for details.

(2) RV-7FR series (1F-DH-04)

Table 2-24 : Configuration devices (RV-7FR series)

No.	Part name	Qty.	Mass (kg)	Remarks
<1>	Stopper plate	2	1.1	One piece each for + side/- side
<2>	Fixing block A	2		One piece each for + side/- side
<3>	Fixing block B	1		+ side
<4>	Fixing block C	1		- side
<5>	Variable stopper block	2		One piece each for + side/- side
<6>	Screw (M12x25)	2		Use for mechanical stopper screw A and B
<7>	Screw (M8x25)	14		For fixing
<8>	Screw (M8x20)	4		For fixing

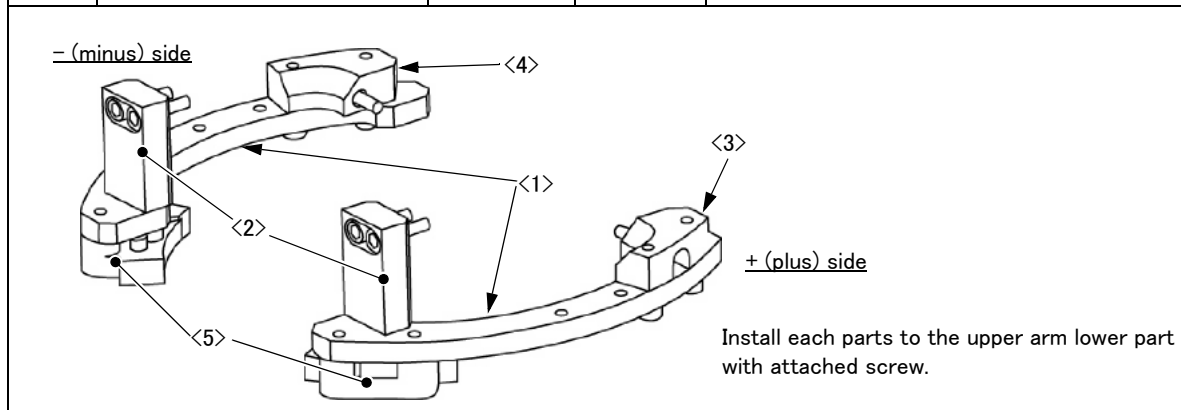

Table 2-25 : Changeable angle (RV-7FR series)

Item	Standard	Changeable angle (combination of + side/- side) (Unit: Degree)			
+ (plus) side	+240	+35	+77	<b>+99</b>	<b>+141</b>
Variable stopper block angle	-	+38	+80	<b>+102</b>	<b>+144</b>
Variable stopper block position <sup>Note1)</sup>	-	(a)	(b)	(a)	(b)
Mechanical stopper screw A <sup>Note2)</sup>	-	Use		Disuse <sup>Note3)</sup>	
Parameter (MEJAR) setting value	+240	+35	+77	+99	+141
- (minus) side	-240	-35	-77	<b>-99</b>	<b>-141</b>
Variable stopper block angle	-	-38	-80	<b>-102</b>	<b>-144</b>
Variable stopper block position <sup>Note1)</sup>	-	(d)	(c)	(d)	(c)
Mechanical stopper screw B <sup>Note2)</sup>	-	Use		Disuse <sup>Note3)</sup>	
Parameter (MEJAR) setting value	-240	-35	-77	-99	-141

Note1) Symbol: “(a)” – “(d)” are related with the symbol of Page 86 “Fig. 2-41: Installation image of J1axis operating range change option (RV-4FR/7FR series)”.

Note2) In the table, it means that “Disuse” does not install the screw, and “Use” does install the screw.

Note3) Mechanical stopper screw which is either one of the two is always necessary. For this reason, the combination enclosed by the thick line of the square in the table (both of + (plus) side and - (minus) side are 99 or 141) cannot be used.

Example) It cannot be used that set +141 as the plus side and set -99 as the minus side simultaneously. The other combination can be set up.

- 1) The changeable angle of RV-7FR series is shown in Table 2-25. The changeable angle shown in Table 2-25 indicates the operation range by the software. The limit by the mechanical stopper is positioned three degrees outward from that angle, so take care when designing the layout.
- 2) The changeable angle can be set independently on the + (plus) side/ - (minus) side, within the condition shown in Table 2-25.

- 3) The operating range is changed with robot arm settings and parameter settings. Refer to the separate "Instruction Manual/ROBOT ARM SETUP & MAINTENANCE" or "Instruction Manual/Detailed Explanation of Functions and Operations" for details.

(3) Installation image (RV-4FR/7FR series)

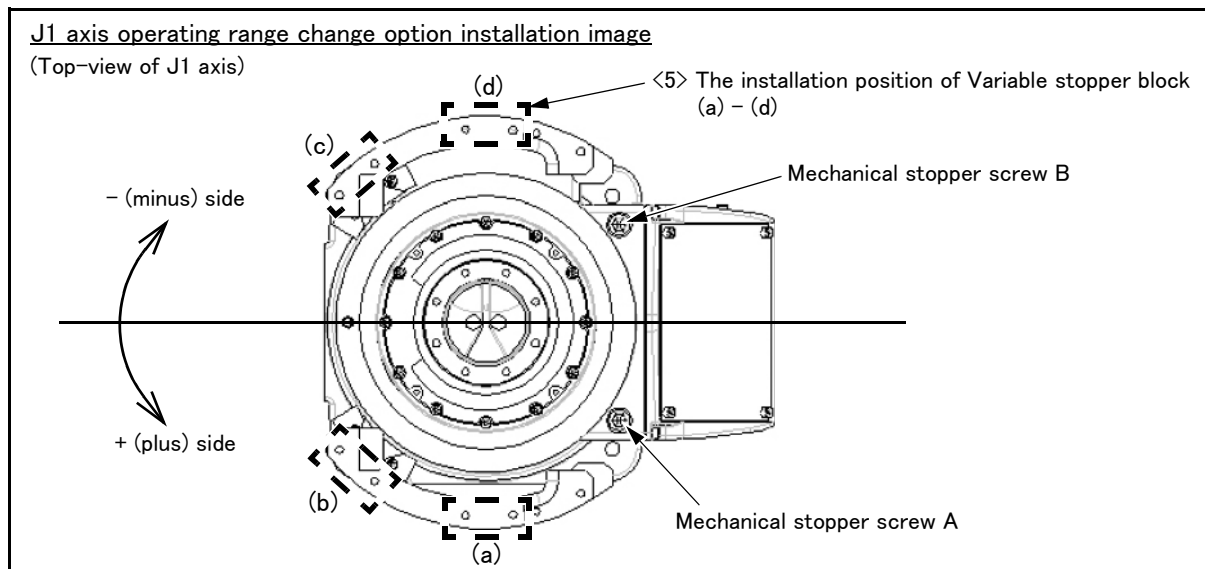

Fig.2-41 : Installation image of J1axis operating range change option (RV-4FR/7FR series)

[Example] In the RV-7FR series, when limiting the +side to +35 degree, and the -side to -141 degree, install as following.

Variable stopper block: Installs in the position of (a), and the position of (c).

Mechanical stopper screw A: Install.

Mechanical stopper screw B: Do not install.

(4) RV-13FR series (1F-DH-05J1)

Table 2-26 : Configuration devices (RV-13FR series)

No.	Part name	Qty.	Mass (kg)	Remarks
<1>	Stopper Block J1	1	0.3	
<2>	Resin Stopper B	2		One piece each for + side/- side
<3>	Screw (M12 × 20)	2		Mechanical Stopper screw
<4>	Screw (M10 × 40)	2		For Stopper Block J1 fixing
<5>	Screw (M4 × 12)	4		For Resin Stopper B fixing

<1>Stopper Block J1

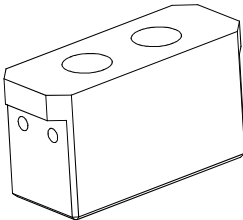

<2>Resin Stopper B

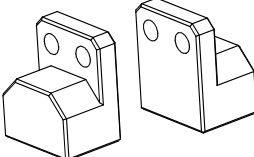

Install each parts to behind the J1 axis of robot arm with attached screw.

Table 2-27 : Changeable angle (RV-13FR series)

Item	Standard	Changeable angle	
+ (plus) side	+190	+30	+120
Mechanical Stopper screw position <sup>Note1)</sup>	-	(A)	(B)
Mechanical Stopper position	+193	+32.5	+122.5
Parameter (MEJAR) setting value	+190	+30	+120
+ (minus) side	-190	-30	-120
Mechanical Stopper screw position <sup>Note1)</sup>	-	(D)	(C)
Mechanical Stopper position	-193	-32.5	-122.5
Parameter (MEJAR) setting value	-190	-30	-120

Note1) Symbol: “(A)” – “(D)” in the Table 2-27 is related with the symbol of “Fig. 2-42: Installation image of J1 axis operating range change option (RV-13FR series)”.

- 1) The changeable angle of RV-13FR series is shown in Table 2-27. The changeable angle shown in Table 2-27 indicates the operation range by the software. The limit by the mechanical stopper is positioned three degrees outward from that angle, so take care when designing the layout.
- 2) The changeable angle can be set independently on the + (plus) side/ - (minus) side, within the condition shown in Table 2-27.
- 3) The operating range is changed with robot arm settings and parameter settings. Refer to the separate “Instruction Manual/ROBOT ARM SETUP & MAINTENANCE” or “Instruction Manual/Detailed Explanation of Functions and Operations” for details.



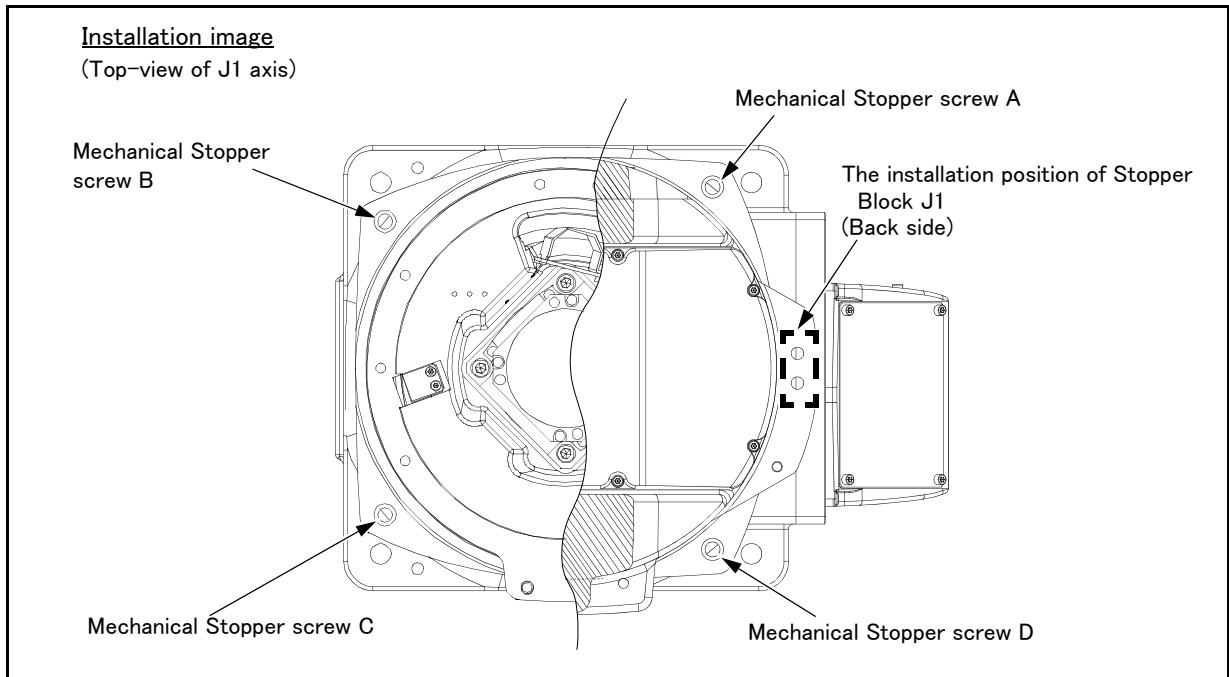

Fig.2-42 : Installation image of J1axis operating range change option (RV-13FR series)

[Example] In the RV-13FR series, when limiting + side to +32.5 degree and - side to -122.5 degree, install the Mechanical Stopper screw in the position of (A) and (C).

(4) Solenoid valve set (RV-2FR series)

- Order type : One set : 1E-VD01(Sink type)/1E-VD01E (Source type)  
Two sets : 1E-VD02(Sink type)1E-VD02E (Source type)

■ Outline

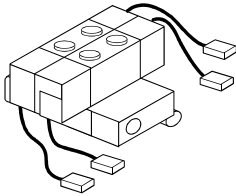

The solenoid valve set is an option that is used for controlling toolings when various toolings, such as the hand, are installed at the end of the arm. Also, for easy installation of this electromaagnetic set onto the robot, it comes equipped with a manifold, couplings, connectors, among other things.

■ Configuration

Table 2-28 : Configuration equipment

Part name	Type	Q'ty		Remark
		One set	Two sets	
Solenoid valve set (1 set)	1E-VD01/1E-VD01E	1 pc.	—	M3 x 25 two screws (installation screws).
Solenoid valve set (2 sets)	1E-VD02/1E-VD02E	—	1 pc.	

■ Specifications

Table 2-29 : Valve specifications

Item	Specifications
Number of positions	2
Port	5 <sup>Note1)</sup>
Valve function	Double solenoid
Operating fluid	Clean air <sup>Note2)</sup>
Operating method	Internal pilot method
Effective sectional area (CV value)	1.5mm <sup>2</sup> (0.08)
Oiling	Unnecessary
Operating pressure range	0.2 to 0.7MPa
Response time	12msec or less
Max. operating frequency	5Hz
Ambient temperature	5 to 50 °C

Note1) Couplings of unused solenoid valves must be blocked with plugs. If they are not blocked, supplied air will blow out from the couplings, lowering the air pressure of the solenoid valves being used and making them nonfunctional.

Recommended plugs: KQ2P-04 plug made by SMC

Note2) **⚠ CAUTION** The air to be provided must be clean, i.e., filtered with a mist separator or air filter. Failing to do so may lead to malfunctions.

Table 2-30 : Solenoid specifications

Item	Specifications
Method	Built-in fly-wheel diodes with surge protection
Operation voltage	DC24V ± 10%
Current value	40mA
Insulation	B type
Insulation resistance	100MΩ or more
Surge protection	Fly-wheel diode

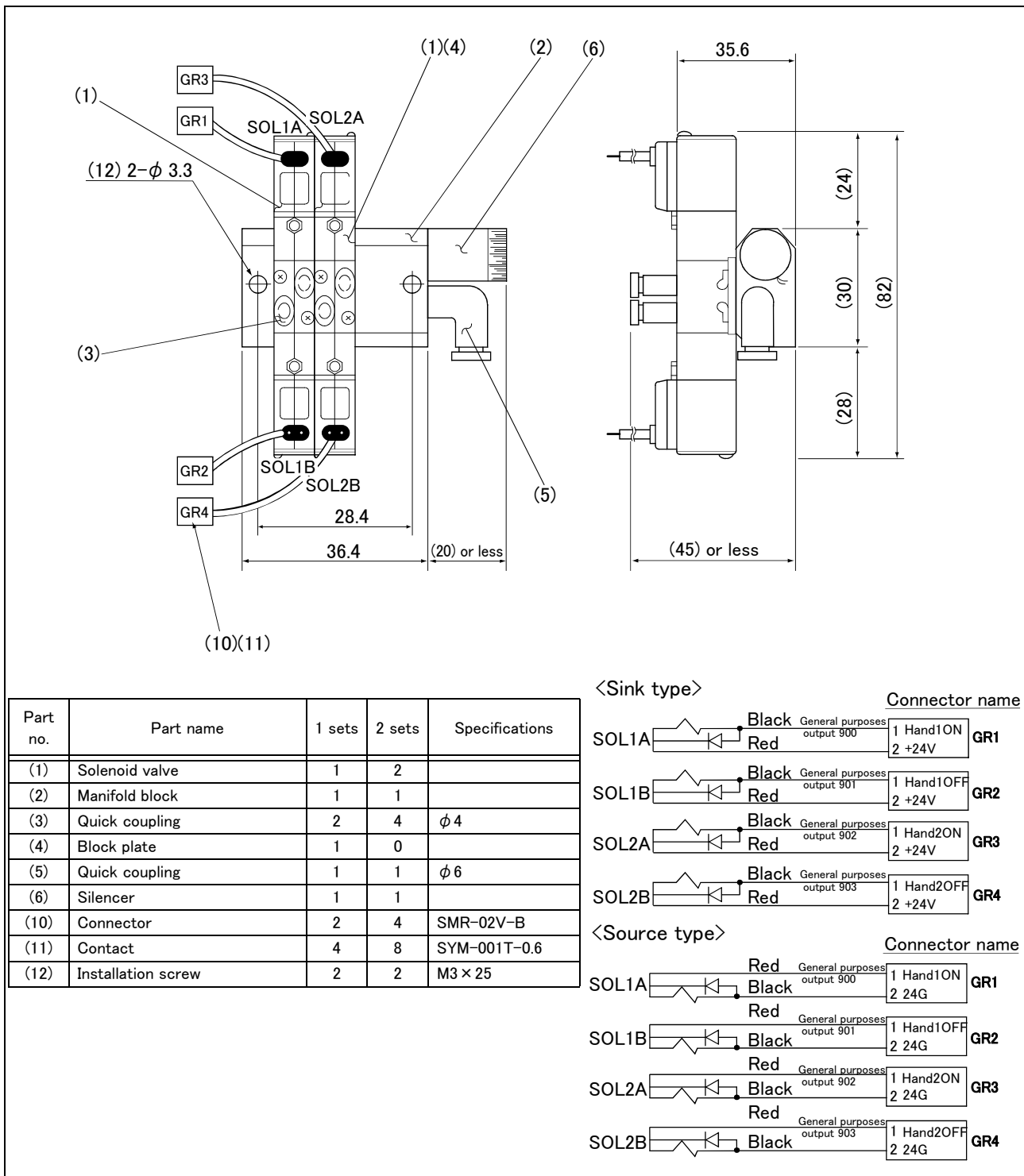

Fig.2-43 : Outline dimensional drawing

(5) Solenoid valve set (RV-4FR/7FR/13FR series)

- Order type: One set: 1F-VD01-\*\*(Sink type)/1F-VD01E-\*\*(Source type)
- Two sets: 1F-VD02-\*\*(Sink type)/1F-VD02E-\*\*(Source type)
- Three sets: 1F-VD03-\*\*(Sink type)/1F-VD03E-\*\*(Source type)
- Four sets: 1F-VD04-\*\*(Sink type)/1F-VD04E-\*\*(Source type)

Note) “-\*\*” differs by robot arm.  
 · RV-4FR/7FR series and RV-7FRL “-02”  
 · RV-13FR/13FRL and RV-20FR “-03”

■ Outline

1F-VD0\*-02



1F-VD0\*-03



The solenoid valve set is an option that is used for controlling toolings when various toolings, such as the hand, are installed at the end of the arm.

Also, for easy installation of this electromaagnetic set onto the robot, it comes equipped with a manifold, couplings, connectors, among other things.

■ Configuration

Table 2-31 : Configuration equipment

Part name	Type <sup>Note1)</sup>	Q'ty				Mass(kg) Note2)	Remark
		One set	Two sets	Three sets	Four sets		
Solenoid valve set (1 set)	1F-VD01-**/ 1F-VD01E-**	1 pc.	—	—	—	0.3	Hand output cable is already connected. Refer to Page 96, “(7) Hand input cable (RV-4FR/7FR/13FR series)”. 1F-VD0*-**: Sink type 1F-VD0*E-**: Source type. Coupling size of A/B-port (output side of solenoid valve) · 1F-VD0*-02/1F-VD0*E-02: Φ4 · 1F-VD0*-03/1F-VD0*E-03: Φ6
Solenoid valve set (2 sets)	1F-VD02-**/ 1F-VD02E-**	—	1 pc.	—	—	0.4	
Solenoid valve set (3 sets)	1F-VD03-**/ 1F-VD03E-**	—	—	1 pc.	—	0.4	
Solenoid valve set (4 sets)	1F-VD04-**/ 1F-VD04E-**	—	—	—	1 pc.	0.5	

Note1) “-\*\*” differs by robot arm. (Refer to “ ■ Order type” above)

Note2) Mass indicates one set.

■ Specifications

Table 2-32 : Valve specifications

Item	Specifications
Number of positions	2
Port	5 <sup>Note1)</sup>
Valve function	Double solenoid
Operating fluid	Clean air <sup>Note2)</sup>
Operating method	Internal pilot method
Effective sectional area (CV value)	1.1mm <sup>2</sup> (0.06)
Oiling	Unnecessary
Operating pressure range	0.1 to 0.7MPa
Response time	22msec or less (at 0.5 MPa)
Max. operating frequency	5Hz
Ambient temperature	-10 to 50 °C (However, there must be no condensation.)

Note1) Couplings of unused solenoid valves must be blocked with plugs. If they are not blocked, supplied air will blow out from the couplings, lowering the air pressure of the solenoid valves being used and making them nonfunctional.

Recommended plugs: KQ2P-04 plug made by SMC (for 1F-VD0\*-02/1F-VD0\*-02)  
 KQ2P-06 plug made by SMC (for 1F-VD0\*-03/1F-VD0\*-03)

Note2)



**CAUTION** The air to be provided must be clean, i.e., filtered with a mist separator or air filter. Failing to do so may lead to malfunctions.

Table 2-33 : Solenoid specifications

Item	Specifications
Method	Built-in fly-wheel diodes with surge protection
Coil rated voltage	DC24V $\pm$ 10%
Power consumption	0.55W
Voltage protection circuit with power surge protection	Diode

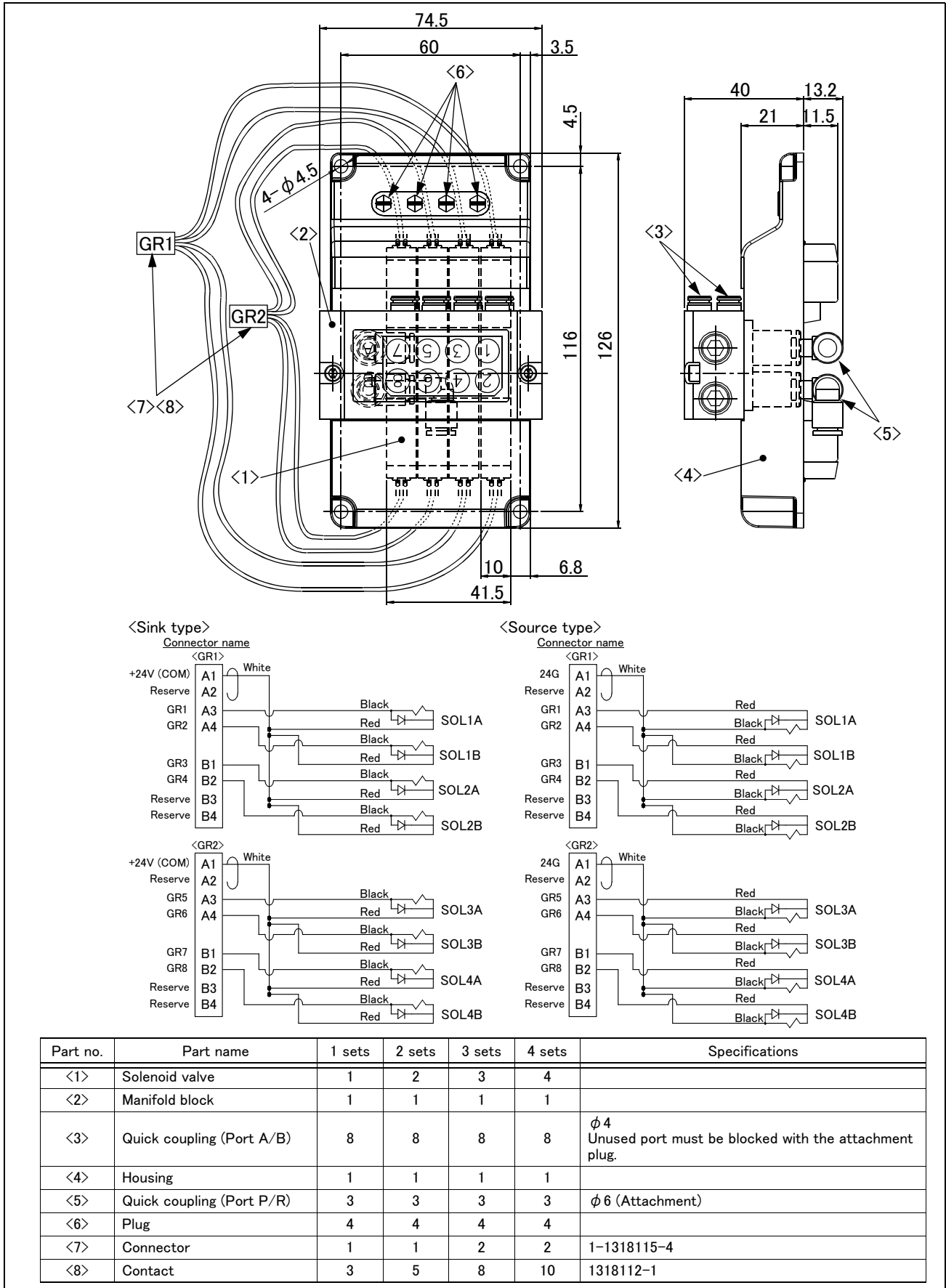

Fig.2-44 : Outline dimensional drawing (1F-VD0\*-02/1F-VD0\*E-02)

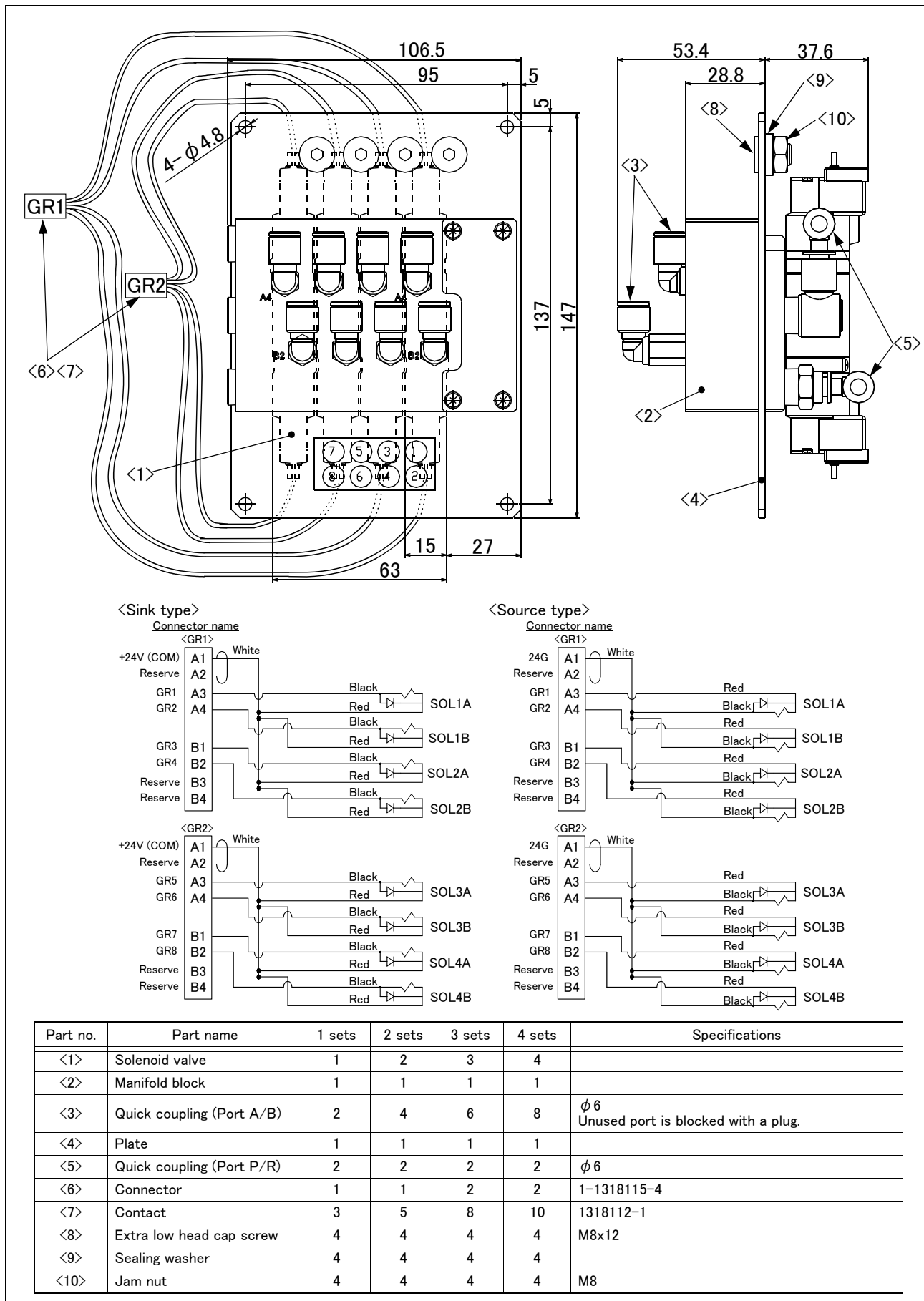

Fig.2-45 : Outline dimensional drawing (1F-VD0\*-03/1F-VD0\*E-03)

(6) Hand input cable (RV-2FR series)

■ Order type: 1S-HC30C-11

■ Outline



The hand input cable is used for customer-designed pneumatic hands. It is necessary to use this to receive the hand's open/close confirmation signals and grasping confirmation signals, at the controller. One end of the cable connects to the connector for hand input signals, which is in the wrist section of the hand. The other end of the cable connected to the sensor inside the hand customer designed.

■ Configuration

Table 2-34 : Configuration equipment

Part name	Type	Qty.	Mass (kg) <sup>Note1)</sup>	Remarks
Hand input cable	1S-HC30C-11	1 cable	0.2	

Note1) Mass indicates one set.

■ Specifications

Table 2-35 : Specifications

Item	Specifications	Remarks
Size x cable core	AWG#24 (0.2 mm <sup>2</sup> ) × 12 cores	One-sided connector, one-sided cable bridging
Total length	700mm (Including the curl section, which is 300mm long)	

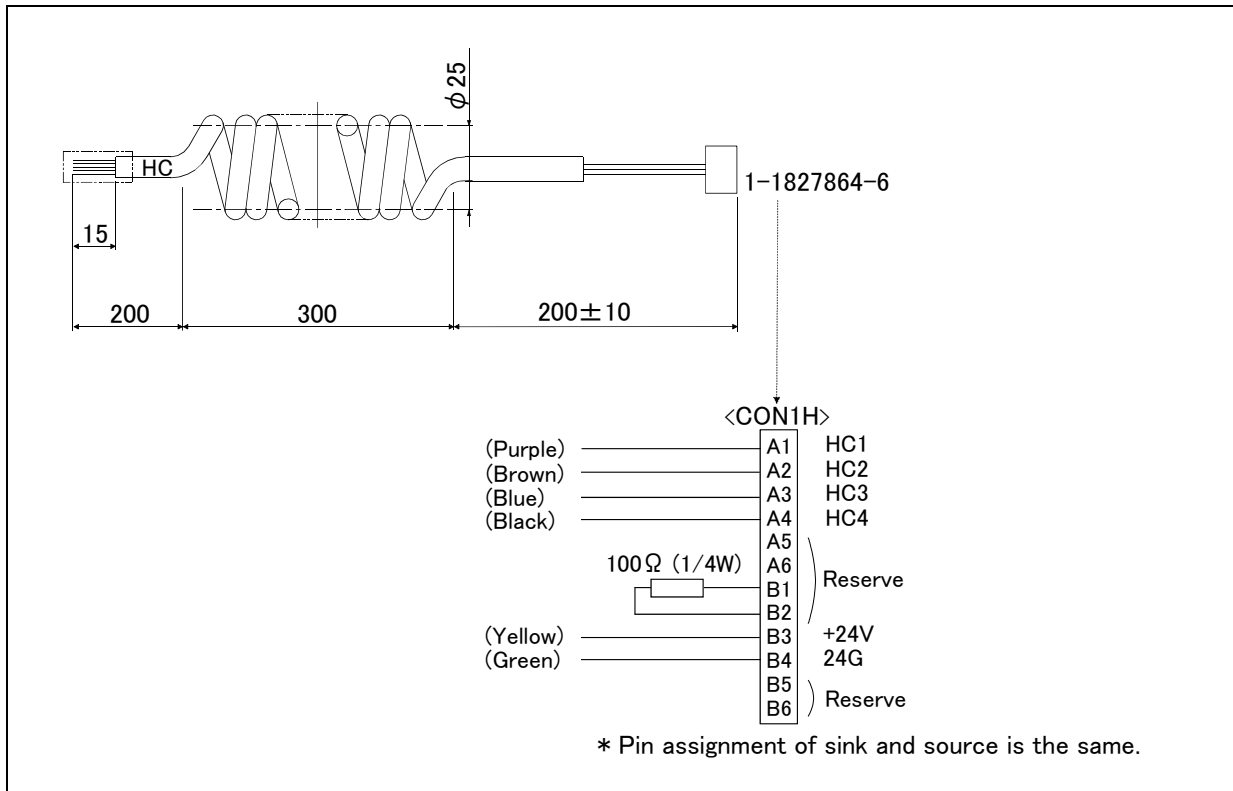

Fig.2-46 : Outside dimensional drawing and pin assignment



## (7) Hand input cable (RV-4FR/7FR/13FR series)

■ Order type: 1F-HC35S-02

■ Outline



The hand input cable is used for customer-designed pneumatic hands. It is necessary to use this to receive the hand's open/close confirmation signals and grasping confirmation signals, at the controller. One end of the cable connects to the connector for hand input signals, which is in the wrist section of the hand. The other end of the cable connected to the sensor inside the hand customer designed.

■ Configuration

Table 2-36 : Configuration equipment

Part name	Type	Qty.	Mass (kg) <sup>Note1)</sup>	Remarks
Hand input cable	1F-HC35S-02	1 cable	0.2	

Note1) Mass indicates one set.

■ Specifications

Table 2-37 : Specifications

Item	Specifications	Remarks
Size x cable core	AWG#24 (0.2 mm <sup>2</sup> ) x 12 cores	One-sided connector, one-sided cable bridging
Total length	1,000 mm	

Pin assign of the hand input cable is shown below.

Table 2-38 : Pin assign of hand input cable

Color	Connector <sup>Note1)</sup>	Pin number: names	Color	Connector <sup>Note1)</sup>	Pin number: names
Purple	OP1	A1: HC1	Yellow	OP3	A1: +24V(HND)
Brown		A2: HC2	Green		A2: RG(HND)
Blue		A3: HC3	-		Reserved
Black		A4: HC4	-		Reserved
Red		B1: HC5			
White		B2: HC6			
Gray		B3: HC7			
Pink		B4: HC8			

Note1) The connector shows the connector name connected to the robot-arm side.

[Caution] This option can be installed on clean-type, but its cleanliness is not under warranty.

(8) Hand output cable (RV-2FR series)

■ Order type: 1E-GR35S

■ Outline

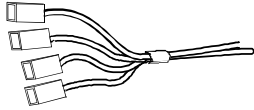

The hand output cable (solenoid valve connection cable) is an option that is used when a solenoid valve other than one of the solenoid valve set options, is used. One end of the cable has a connector that connects to the input terminal inside the robot. The other end of the cable is connected.

■ Configuration

Table 2-39 : Configuration equipment

Part name	Type	Qty.	Mass (kg) <sup>Note1)</sup>	Remarks
Hand output cable	1E-GR35S	1 cable	0.1	

Note1) Mass indicates one set.

■ Specifications

Table 2-40 : Specifications

Item	Specifications	Remarks
Size x Cable core	AWG#22(0.3mm <sup>2</sup> ) x 8 cores	One side connector and one side cable connection
Total length	350mm	

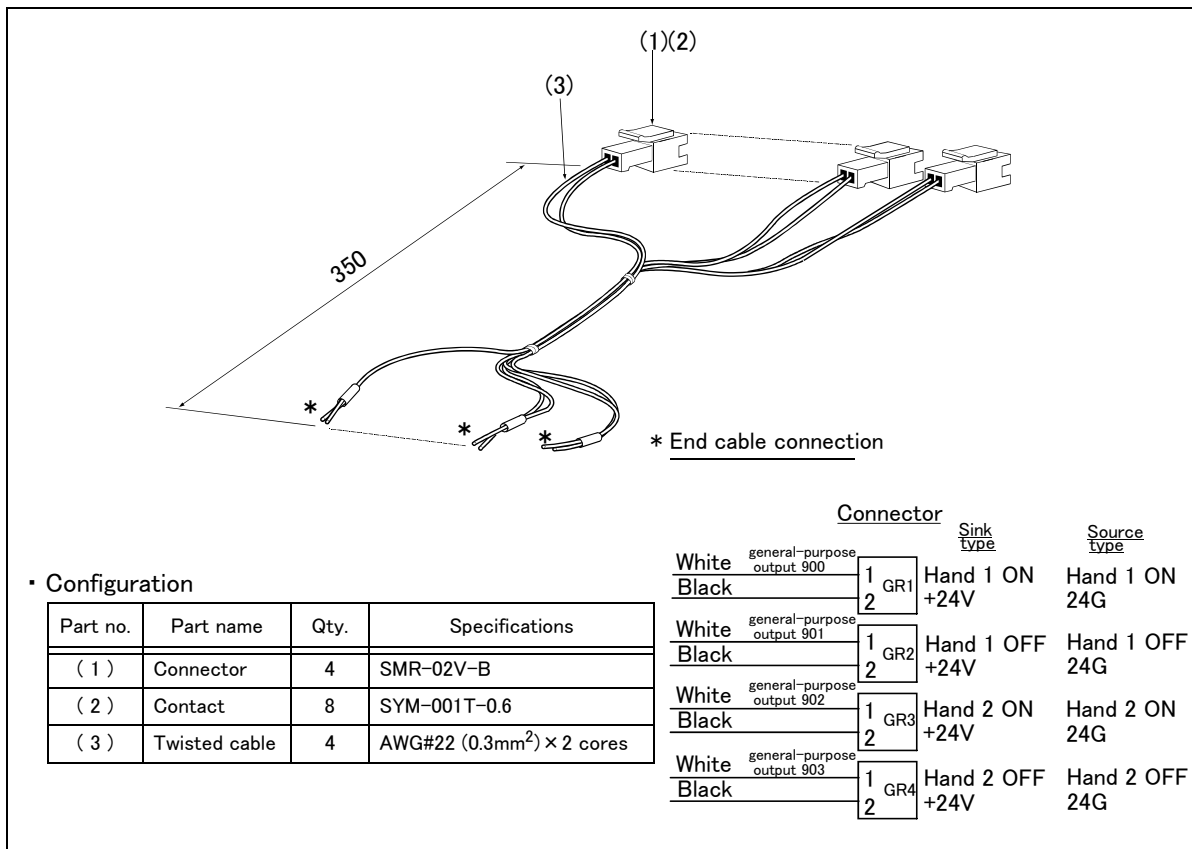

Fig.2-47 : Outline dimensional drawing and pin assignment

## (9) Hand output cable (RV-4FR/7FR/13FR series)

■ Order type: 1F-GR35S-02

■ Outline



The hand output cable (solenoid valve connection cable) is an option that is used when a solenoid valve other than one of the solenoid valve set options, is used. One end of the cable has a connector that connects to the input terminal inside the robot. The other end of the cable is connected.

■ Configuration

Table 2-41 : Configuration equipment

Part name	Type	Qty.	Mass (kg) <sup>Note1)</sup>	Remarks
Hand output cable	1F-GR35S-02	1 cable	0.1	

Note1) Mass indicates one set.

■ Specifications

Table 2-42 : Specifications

Item	Specifications	Remarks
Size x Cable core	AWG#24(0.2 mm <sup>2</sup> ) x 10 cores	One side connector and one side cable connection
Total length	500 mm	

Pin assign of the hand output cable is shown below.

Table 2-43 : Pin assign of hand output cable

Color	Connector	Pin number: names	Color	Connector	Pin number: names
Yellow	GR1	A1: +24V	Green	GR2	A1: +24V
-		A2: Reserved	-		A2: Reserved
Purple		A3: GR1 (Hand output 1)	Red		A3: GR5 (Hand output 5)
Brown		A4: GR2 (Hand output 2)	White		A4: GR6 (Hand output 6)
Blue		B1: GR3 (Hand output 3)	Gray		B1: GR7 (Hand output 7)
Black		B2: GR4 (Hand output 4)	Pink		B2: GR8 (Hand output 8)
-		B3: Reserved	-		B3: Reserved
-		B4: Reserved	-		B4: Reserved

[Caution] This option can be installed on clean-type, but its cleanliness is not under warranty.

(10) Hand curl tube

- Order type: RV-2FR/4FR/7FR series, RV-7FRLL ...One set: 1E-ST0402C  
Two sets: 1E-ST0404C
- RV-4FR/7FR series, RV-7FRLL.....Three sets: 1E-ST0406C  
Four sets: 1E-ST0408C
- RV-13FR/13FRL, RV-20FR.....One set: 1N-ST0602C  
Two sets: 1N-ST0604C  
Three sets: 1N-ST0606C  
Four sets: 1N-ST0608C

■ Outline

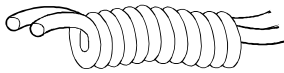

The hand curl tube is a curl tube for the pneumatic hand.

■ Configuration

Table 2-44 : Configuration equipment

Part name	Type	Qty.	Mass(kg) <sup>Note1)</sup>	Remarks
RV-2FR/4FR/7FR series, RV-7FRLL				
Hand curl tube (One set: 2 pcs.)	1E-ST0402C	1 pc.	0.1	φ 4 tube, 2pcs.
Hand curl tube (Two sets: 4 pcs.)	1E-ST0404C	1 pc.	0.1	φ 4 tube, 4pcs.
RV-4FR/7FR series, RV-7FRLL				
Hand curl tube (Three sets: 6 pcs.)	1E-ST0406C	1 pc.	0.1	φ 4 tube, 6pcs.
Hand curl tube (Four sets: 8 pcs.)	1E-ST0408C	1 pc.	0.1	φ 4 tube, 8pcs.
RV-13FR/13FRL, RV-20FR				
Hand curl tube (One set: 2 pcs.)	1N-ST0602C	1 pc.	0.1	φ 6 tube, 2pcs.
Hand curl tube (Two sets: 4 pcs.)	1N-ST0604C	1 pc.	0.1	φ 6 tube, 4pcs.
Hand curl tube (Three sets: 6 pcs.)	1N-ST0606C	1 pc.	0.1	φ 6 tube, 6pcs.
Hand curl tube (Four sets: 8 pcs.)	1N-ST0608C	1 pc.	0.1	φ 6 tube, 8pcs.

Note1) Mass indicates one set.

■ Specifications

Table 2-45 : Specifications

Item	Specifications
Material	Urethane
Size	1E-ST040*C : Outside diameter φ 4 × Inside diameter φ 2.5 1N-ST060*C : Outside diameter φ 6 × Inside diameter φ 4

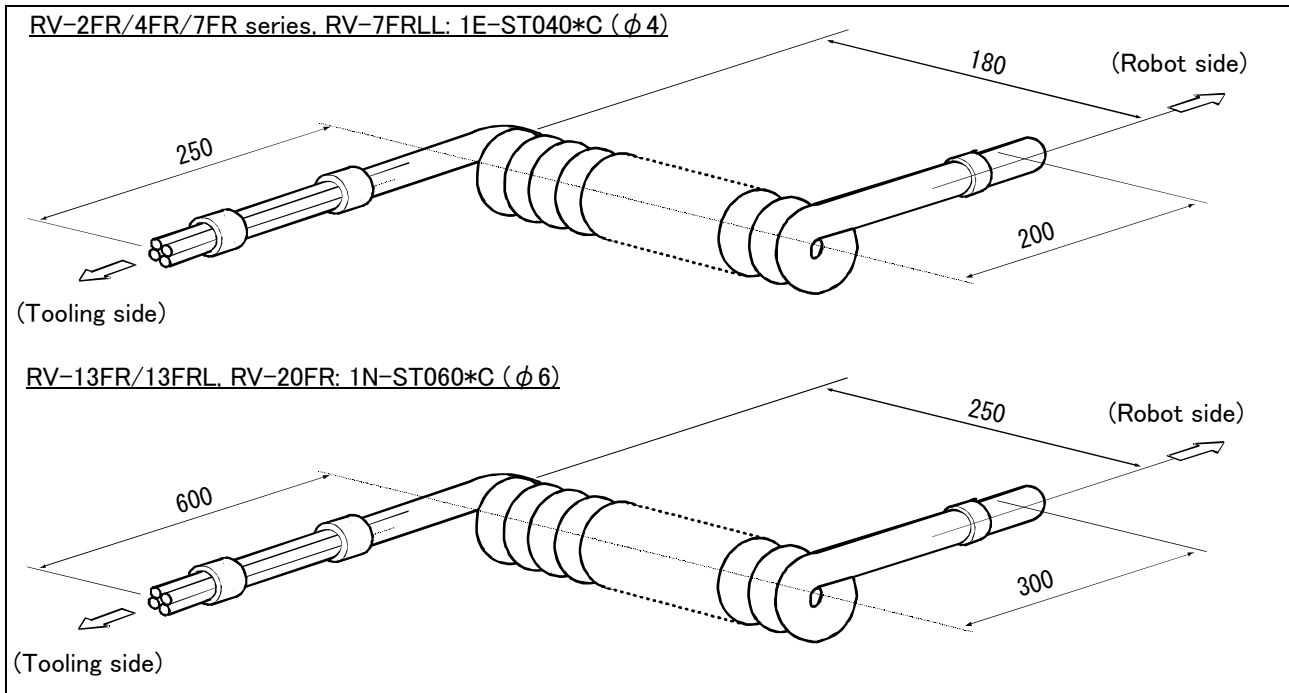

Fig.2-48 : Outline dimensional drawing

[Caution] This option can be installed on clean-type, but its cleanliness is not under warranty.

(11) Forearm external wiring set/ Base external wiring set (RV-4FR/7FR/13FR series)

■ Order type

Forearm external wiring set: 1F-HB01S-01 (Hand input signals, vision-sensor, force sensor or multifunctional electric hand)  
 1F-HB02S-01 (Force sensor, vision-sensor, and multifunctional electric hand)

Base external wiring set: 1F-HA01S-01 (Vision-sensor, force sensor or multifunctional electric hand)  
 1F-HA02S-01 (Vision-sensor, force sensor, and multifunctional electric hand)

Note) In the Internal wiring and piping specification, the corresponding base external wiring set is attached.

■ Outline

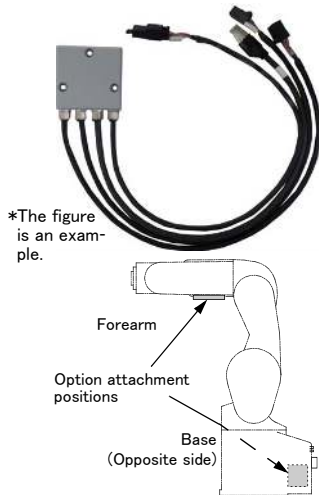

The Forearm external wiring set and the Base external wiring set are used to pull out the hand input signal cables and communication cables etc. from the underneath of the forearm and the side of the base.

1) Hand input cable

The hand input cable of the option (equivalent of 1F-HC35S-02) is installed. Connect to the connectors OP1 and OP3 of the hand input cable, which is built into the forearm. Connect the user connection side of pulled-out cable to the tools etc, and input the signals.

2) Communication cable

Pulls out the cable which attached the connector for connecting with vision sensor and multifunctional electric hand. The pulled out cables from the underneath of the forearm are connected with a vision sensor camera, a force sensor, or a multifunctional electric hand. The pulled out cables from the side of the base are connected with a vision sensor controller, a force sensor interface, or a multifunctional electric hand controller. (To connect to a force sensor, use the adaptor cable that is supplied in the force sensor option.)

■ Configuration

Table 2-46 : Configuration equipment

Part name	Type	Qty.	Remarks
Forearm external wiring set	1F-HB01S-01	Either one pc.	
	1F-HB02S-01		
Base external wiring set	1F-HA01S-01	Either one pc.	
	1F-HA02S-01		

## ■ Specification

The kind of cable which can be pulled out for each option is shown in [Table 2-47](#). Because to pull out the cable of the same purpose also as the forearm side and the base side, you should use the option in pair shown in “the pairing (recommendation)” of the table. And, each wiring system figure is shown after the following page.

Table 2-47 : Internal wiring and piping specification types

Pairing (recomm endation)	Option type	Cable length (mm) <small>Note1)</small>	Wiring (cable for the connection to each equipment)			
			Hand input signal <small>Note2)</small>	Vision sensor camera	Force sensor unit	Multifunctional electric hand
1	1F-HB01S-01 (Forearm)	1,000	Eight points	1	Either one unit	
	1F-HA01S-01 (Base)	500	–	1	Either one unit	
2	1F-HB02S-01 (Forearm)	1,000	–	1	1	1
	1F-HA02S-01 (Base)	500	–	1	1	1

Note1) The length indicates a part of the cable pulled out from the cable clamp box.

Note2) Although the connector is attached to the customer wiring side of hand input cable, the connector can be cut, and connect to the tool of the customer preparation. The color and signal name of the wire are shown in [Table 2-48](#).

Table 2-48 : Color of the wire and signal name (hand input cable)

Color	Signal name	Connector (HC)	Color	Signal name	Connector (HC)	Color	Signal name	Connector (HC)	Color	Signal name	Connector (HC)
Violet	HC1	A1	Brown	HC2	A2	Blue	HC3	A3	Black	HC4	A4
Red	HC5	B1	White	HC6	B2	Gray	HC7	B3	Pink	HC8	B4
Yellow	+24V(HND)	A6	Green	RG(HND)	B6	–					

1) Wiring system diagram (1F-H\*01S-01: Hand input signals, multifunctional electric hand/force sensor, and vision sensor)

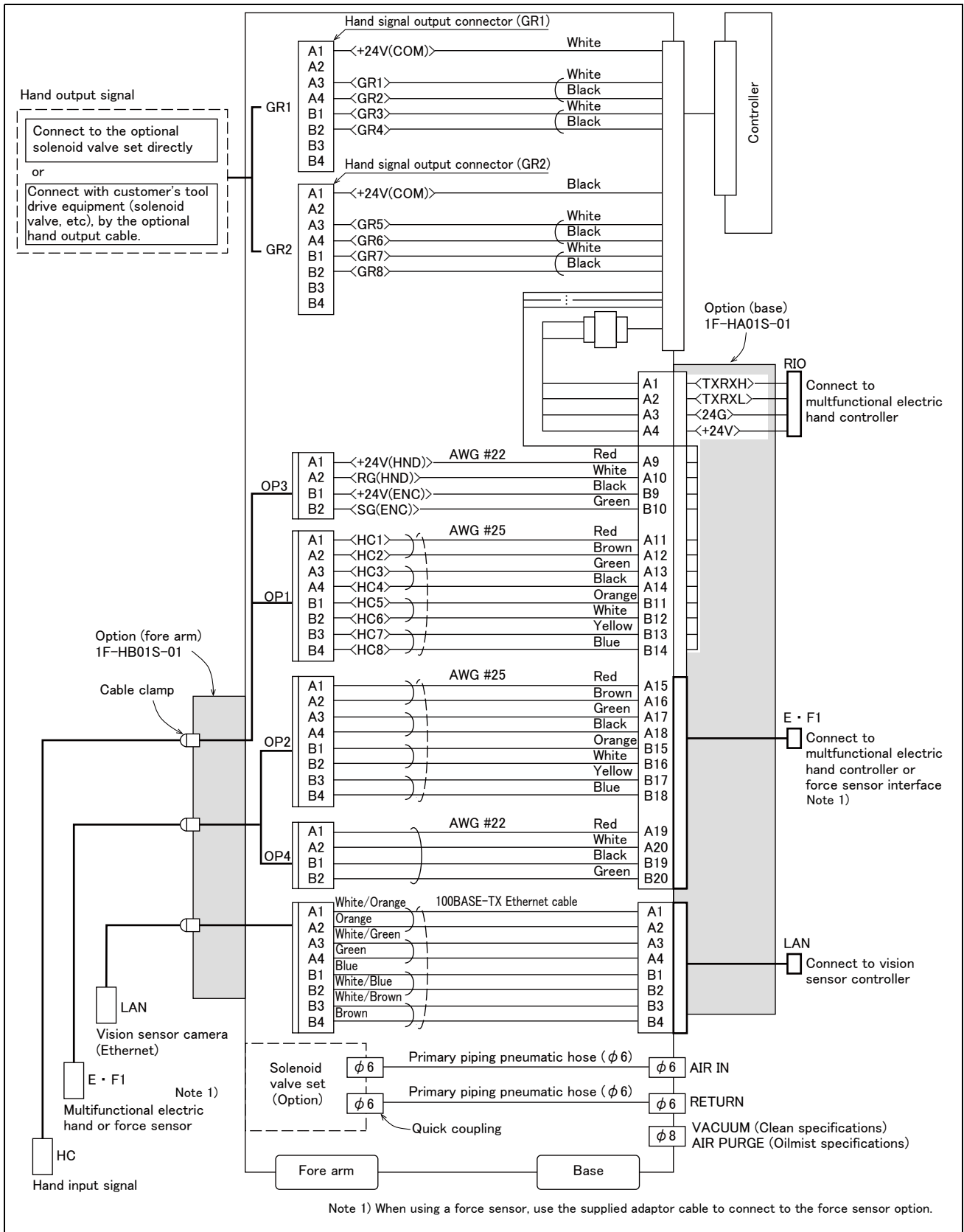

Fig.2-49 : Wiring system diagram (1F-H\*01S-01)



2) Wiring system diagram (1F-H\*02S-01: Multifunctional electric hand, force sensor, and vision-sensor)

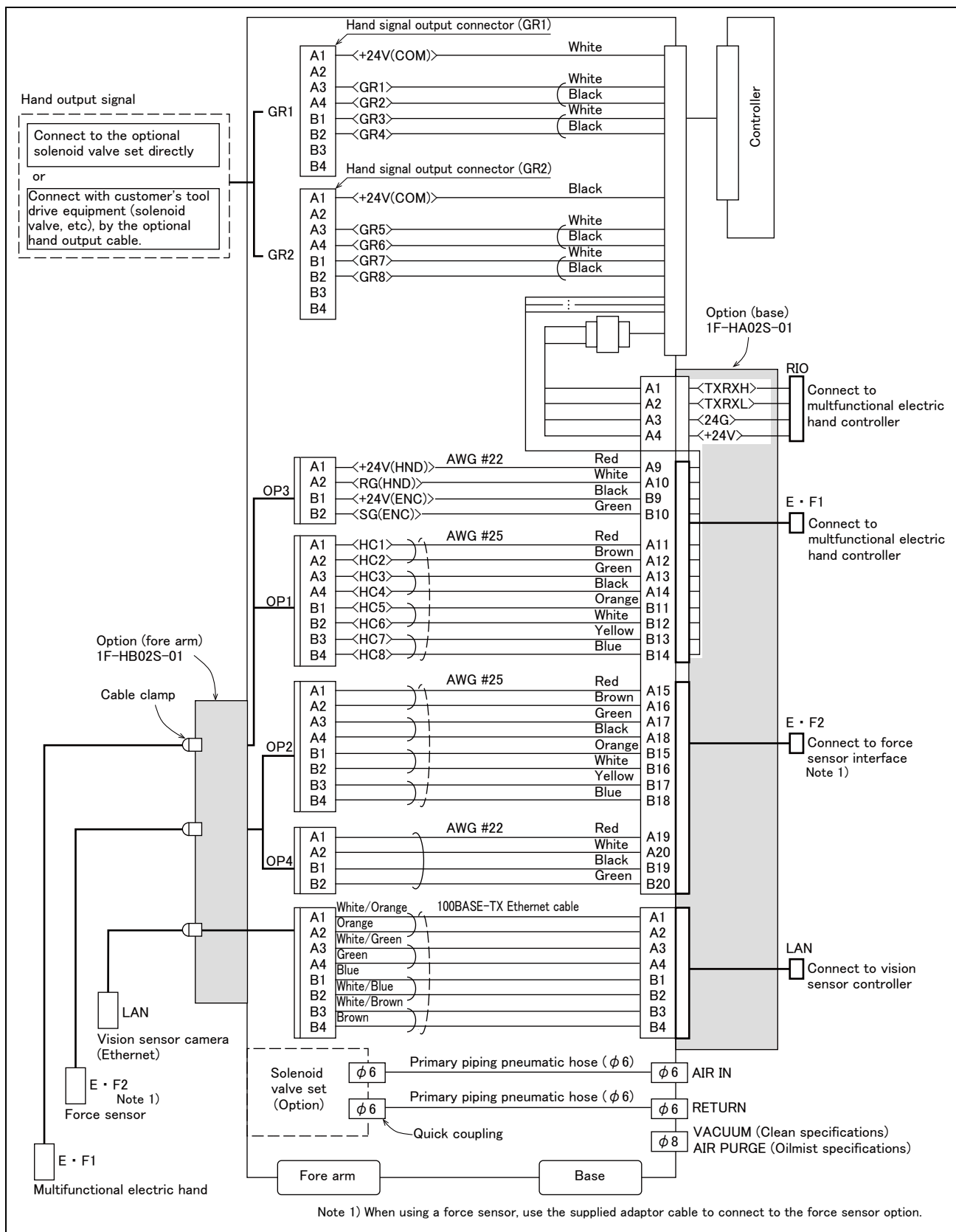

Fig.2-50 : Wiring system diagram (1F-H\*02S-01)

## 2.7 About Overhaul

Robots which have been in operation for an extended period of time can suffer from wear and other forms of deterioration. In regard to such robots, we define overhaul as an operation to replace parts running out of specified service life or other parts which have been damaged, so that the robots may be put back in shape for continued use. As a rule of thumb, it is recommended that overhaul be carried out before the total amount of servo-on time reaches the specified time (24,000 hours for the robot arm and 36,000 hours for the controller). However, the degree of the equipment's wear and deterioration presumably varies depending on their operating conditions. Especially for operation with high load and frequency, the maintenance cycle may be shorter. For details on the part selection for replacement and the timing of overhaul, contact your dealer.

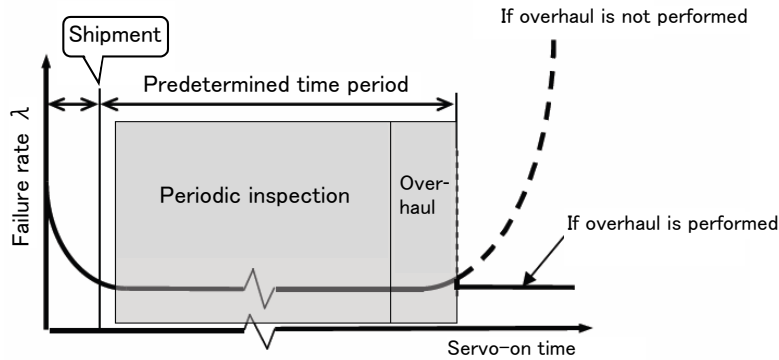

Fig.2-51 : Periodic inspection/overhaul periods

## 2.8 Maintenance parts

A long-term use of industrial robots causes a malfunction due to wear or deterioration of their components, as well as general machines. To prevent such a malfunction and perform smooth operation of the robot for a long term, the regular maintenance, inspection, and replacement of consumable parts are required. Refer to "Maintenance and Inspection" in the separate manual "INSTRUCTION MANUAL/ROBOT ARM SETUP & MAINTENANCE" for details of the maintenance and inspection. The consumable parts used in the robot arm are shown in [Table 2-49](#). Purchase these parts from the designated maker or dealer when required. Some Mitsubishi-designated parts differ from the maker's standard parts. Thus, confirm the part name, robot arm and controller serial No. and purchase the parts from the dealer.

Table 2-49 : Consumable part list

No.	Part name	Type <sup>Note1)</sup>	Usage place	Qty.	Supplier
1	Grease		Reduction gears of each axis	As needed	Mitsubishi Electric
2	Lithium battery	MR-BAT6V1	Base section	4	

Note1) Confirm the robot arm serial No., and contact the dealer or service branch of Mitsubishi Electric Co., for the type.

### 3 Controller

#### 3.1 Standard specifications

##### 3.1.1 Basic specifications

###### (1) CR800-D controller

Table 3-1 : Specifications of CR800-D controller

Item	Unit	Specification	Remarks		
Type		CR800- □ VD CR800-04VJD CR800-07VLD	“ □ ” in type name shows the load (2kg: “02”, 4kg: “04”, 7kg: “07”, 13kg: “13”, 20kg: “20”) of robot arm. CR800-04VJD controller is for RV-4FRJL only. CR800-07VLD controller is for RV-7FRLL only.		
Number of control axis		Simultaneously 6	Additional 8 axes available.		
Memory capacity	Programmed positions	point	39,000		
	No. of steps	step	78,000		
	Number of program		512		
Robot language		MELFA-BASIC V, VI			
Teaching method		Pose teaching method, MDI method <sup>Note1)</sup>			
External input and output	Input and output	point	0/0	Max. 256/256 by option	
	Dedicated input/output		Assigned with general-purpose input/output	The signal number of “STOP” input signals is fixing.	
	Hand open/close input/output	point	4/4 (RV-2FR series) 8/8 (Other models)	The sink/source type can be switched with parameters.	
	Emergency stop input	point	1	Dual line	
	Emergency stop output	point	1	Dual line	Category 4, Performance Level e (ISO13849-1)
	Mode selector switch input <sup>Note2)</sup>	point	1	Dual line	
	Mode output	point	1	Dual line	Category 3, Performance Level d (ISO13849-1)
	Robot error output	point	1	Dual line	
	Addition axis synchronization	point	1	Dual line	
	Door switch input	point	1	Dual line	
Ecoder input	Channel	2			
Interface	Additional axis, force sensor interface	Channel	1	SSCNET III/H (Connect with MR-J4-B series)	
	Communication interface between robot controllers	Channel	2	SSCNET III/H (Optical communication) For daisy chaining.	
	Remote input/output	Channel	1	Compatible with Ver. 1.0/2.0	
	USB	port	1	Ver. 2.0 HighSpeed device functions only. USB mini-B	
	Ethernet	port	1	For customer: 1000BASE-T/ 100BASE-TX/10BASE-T	
			1	Dedicated T/B port: 100BASE-TX/ 10BASE-T	
	Option slot	slot	2	For option interface	
	SD memory card slot	slot	1	For extended memory	
RS-422	port	1	Dedicated T/B port		
Power source	Input voltage range	V	RV-2FR/4FR/7FR series: Single phase AC 200 to 230	The rate of power-supply voltage fluctuation is within 10%. Refer to the table in “ ■ Introduction ” for details of the robot type.	
			RV-13FR series: Single phase AC 230 Single phase AC 200 to 230		
	Power capacity	kVA	RV-2FR series: 0.5 RV-4FR series: 1.0 RV-7FR series: 2.0 RV-13FR series: 3.0		Does not include rush current. <sup>Note3)</sup> Refer to the table in “ ■ Introduction ” for details of the robot type.
	Power supply frequency	Hz	50/60		

Item		Unit	Specification	Remarks
Outline dimensions <sup>Note4)</sup>		mm	430(W) x 425(D) x 99.5(H)	Excluding protrusions
Mass		kg	Approx. 12.5	
Construction			Self-contained floor type, Opened type. Installation vertically or horizontally	IP20 <sup>Note5)</sup>
Ambient temperature	In use	°C	0 to 40	Without freeze
	At transport/storage		-15 to +70	
Ambient humidity	In use	%RH	45 to 85	Without dew drops
	At transport/storage		90 or less	
Overvoltage category <sup>Note6)</sup>			II or less	
Pollution level <sup>Note7)</sup>			2 or less	
Altitude		m	1000 or less	
Grounding		Ω	100 or less	100 Ω or less (class D grounding) <sup>Note8)</sup>
Paint color			Dark gray	Equivalent to Munsell: 3.5PB3.2/0.8, PANTONE: 432C

Note1) Pose teaching method: The method to register the current position of the robot arm.

MDI method: The method to register by inputting the numerical value Immediate.

Note2) Provide a mode selector switch to change the mode (MANUAL/AUTOMATIC) of the controller. Select the switch that meets the following specifications.

- The switch can be locked in each position of the selected mode.
- The selected switch position can be clearly distinguished from each other.
- Only one mode can be selected at a time.

(Recommended switch model: HA1K-2C2A-2 manufactured by IDEC. The key switch can be locked in each position by removing its key.)

The mode can be changed by other means than the selector switch.

For example, the user can use a mode change program. In the program, provide a means to lock the selected mode with a password.

Note3) The power capacity is the recommended value. The power capacity does not include the rush current when the power is turned ON. The power capacity is a guideline and the actual operation is affected by the input power voltage. Use the short circuit breaker which operates by the current leakage under the commercial frequency domain (50–60Hz). If sensitive to the high frequency ingredient, it will become the cause in which below the maximum leak current value carries out the trip.

The following lists the current values of the representative models as a reference.

Model	Item	Current [A]	Apparent power [kVA]	Voltage at measurement [V]	
RV-2FR	At control power ON	0.41	0.09	214.3	
	At servo ON	0.64	0.14	214.5	
	In automatic operation	Effective value	1.23	0.25	213.7
		Peak	4.80	0.99	214.2
RV-4FRL	At control power ON	0.41	0.09	213.6	
	At servo ON	0.93	0.20	212.0	
	In automatic operation	Effective value	2.64	0.46	212.8
		Peak	12.00	2.40	213.2
RV-7FRL	At control power ON	0.40	0.09	214.2	
	At servo ON	0.94	0.20	214.1	
	In automatic operation	Effective value	4.32	0.81	214.5
		Peak	22.50	4.65	214.9
RV-13FR (Single phase)	At control power ON	0.49	0.11	214.9	
	At servo ON	1.35	0.29	214.9	
	In automatic operation	Effective value	6.29	1.30	214.9
		Peak	22.50	4.87	214.9
RV-13FR (Three phase)	At control power ON	0.39	0.14	214.3	
	At servo ON	0.91	0.33	210.7	
	In automatic operation	Effective value	3.12	0.58	216.2
		Peak	12.11	2.25	225.0

Note4) Refer to [Page 120, "3.3.1 Outside dimensions"](#) for details.

Note5) This controller is standard specification. (Refer to [Page 115, "3.1.2 Protection specifications and operating supply"](#).)

Note6) This indicates the section of the power supply to which the equipment is assumed to be connected between the public electrical power distribution network and the machinery within premises.

Category II applies to equipment for which electrical power is supplied from fixed facilities. The surge voltage withstand level for up to the rated voltage of 300V is 2500V.

Note7) This index indicates the degree to which conductive material is generated in terms of the environment in which the equipment is used.

Pollution level 2 is when only non-conductive pollution occurs. A temporary conductivity caused by condensing must be expected occasionally.

Note8) The robot must be grounded by the customer.

## (2) CR800-R controller

Use the robot CPU unit which connects to CR800-R controller, equipping the base unit of the sequencer of the MELSEC iQ-R series of our company. Specifications such as the power supply and outside dimension of the robot CPU unit are the same as the sequencer's specification. Refer to Page 118 "Fig. 3-2" (Names of each part), and Page 121 "Fig. 3-5" (Outside dimensions).

Although the specification with which the robot CPU unit and the controller (box which mounts the servo amplifier for the robots, the safety circuit, etc.) were put together is shown in Table 3-2, the specification of the controller is mainly described.

Table 3-2 : Specifications of CR800-R controller

Item	Unit	Specification	Remarks		
Type		CR800- □ VR CR800-04VJR CR800-07VLR	" □ " in type name shows the load (2kg: "02", 4kg: "04", 7kg: "07", 13kg: "13", 20kg: "20") of robot arm. CR800-04VJR controller is for RV-4FRJL only. CR800-07VLR controller is for RV-7FRLL only.		
Number of control axis		Simultaneously 6	Additional 8 axes available.		
Memory capacity	Programmed positions	point	39,000		
	No. of steps	step	78,000		
	Number of program		512		
Robot language		MELFA-BASIC V, VI			
Teaching method		Pose teaching method, MDI method <sup>Note1)</sup>			
External input and output	Input and output	point	0/0	Multi-CPU shared device Input 8192/Output 8192 (Max.)	
		Dedicated input/output	Assign to the multi-CPU shared device.		
	Hand open/close input/output	point	4/4 (RV-2FR series) 8/8 (Other models)	The sink/source type can be switched with parameters.	
	Emergency stop input	point	1	Dual line	Category 4, Performance Level e (ISO13849-1)
	Emergency stop output	point	1	Dual line	
	Mode selector switch input <sup>Note2)</sup>	point	1	Dual line	Category 3, Performance Level d (ISO13849-1)
	Mode output	point	1	Dual line	
	Robot error output	point	1	Dual line	
	Addition axis synchronization	point	1	Dual line	
Door switch input	point	1	Dual line		
Interface	Additional axis, force sensor interface	Channel	1	SSCNET III/H (Connect with MR-J4-B series)	
	Communication interface between robot controllers	Channel	1	Communication between robot CPU.	
	Remote input/output	Channel	1	Compatible with Ver. 2.0 (safety control)	
	Ethernet	port	1	For customer: 100BASE-T/ 100BASE-TX/10BASE-T	
			1	Dedicated T/B port: 100BASE-TX/ 10BASE-T	
	Option slot	slot	2	Only the function extension card is available.	
	SD memory card slot	slot	1	For extended memory	
RS-422	port	1	Dedicated T/B port		
Power source	Input voltage range	V	RV-2FR/4FR/7FR series: Single phase AC 200 to 230	The rate of power-supply voltage fluctuation is within 10%. Refer to the table in " ■ Introduction " for details of the robot type.	
			RV-13FR series: Single phase AC 230 Single phase AC 200 to 230		
	Power capacity	kVA	RV-2FR series: 0.5 RV-4FR series: 1.0 RV-7FR series: 2.0 RV-13FR series: 3.0	Does not include rush current. <sup>Note3)</sup> Refer to the table in " ■ Introduction " for details of the robot type.	

Item		Unit	Specification	Remarks
Power supply frequency		Hz	50/60	
Outline dimensions <sup>Note4)</sup>		mm	430(W) x 425(D) x 99.5(H)	Excluding protrusions
Mass		kg	Approx. 12.5	
Construction			Self-contained floor type, Opened type. Installation vertically or horizontally	IP20 <sup>Note5)</sup>
Ambient temperature	In use	°C	0 to 40	Without freeze
	At transport/storage		-15 to +70	
Ambient humidity	In use	%RH	45 to 85	Without dew drops
	At transport/storage		90 or less	
Overvoltage category <sup>Note6)</sup>			II or less	
Pollution level <sup>Note7)</sup>			2 or less	
Altitude		m	1000 or less	
Grounding		Ω	100 or less	100Ω or less (class D grounding) <sup>Note8)</sup>
Paint color			Dark gray	Equivalent to Munsell: 3.5PB3.2/0.8, PANTONE: 432C

- Note1) Pose teaching method: The method to register the current position of the robot arm.  
 MDI method: The method to register by inputting the numerical value Immediate.
- Note2) Provide a mode selector switch to change the mode (MANUAL/AUTOMATIC) of the controller. Select the switch that meets the following specifications.
- The switch can be locked in each position of the selected mode.
  - The selected switch position can be clearly distinguished from each other.
  - Only one mode can be selected at a time.
- (Recommended switch model: HA1K-2C2A-2 manufactured by IDEC. The key switch can be locked in each position by removing its key.)  
 The mode can be changed by other means than the selector switch.  
 For example, the user can use a mode change program. In the program, provide a means to lock the selected mode with a password.
- Note3) The power capacity is the recommended value. The power capacity does not include the rush current when the power is turned ON. The power capacity is a guideline and the actual operation is affected by the input power voltage. Use the short circuit breaker which operates by the current leakage under the commercial frequency domain (50–60Hz). If sensitive to the high frequency ingredient, it will become the cause in which below the maximum leak current value carries out the trip.  
 The following lists the current values of the representative models as a reference.

Model	Item	Current [A]	Apparent power [kVA]	Voltage at measurement [V]	
RV-2FR	At control power ON	0.41	0.09	214.3	
	At servo ON	0.64	0.14	214.5	
	In automatic operation	Effective value	1.23	0.25	213.7
		Peak	4.80	0.99	214.2
RV-4FRL	At control power ON	0.41	0.09	213.6	
	At servo ON	0.93	0.20	212.0	
	In automatic operation	Effective value	2.64	0.46	212.8
		Peak	12.00	2.40	213.2
RV-7FRL	At control power ON	0.40	0.09	214.2	
	At servo ON	0.94	0.20	214.1	
	In automatic operation	Effective value	4.32	0.81	214.5
		Peak	22.50	4.65	214.9
RV-13FR (Single phase)	At control power ON	0.49	0.11	214.9	
	At servo ON	1.35	0.29	214.9	
	In automatic operation	Effective value	6.29	1.30	214.9
		Peak	22.50	4.87	214.9
RV-13FR (Three phase)	At control power ON	0.39	0.14	214.3	
	At servo ON	0.91	0.33	210.7	
	In automatic operation	Effective value	3.12	0.58	216.2
		Peak	12.11	2.25	225.0

- Note4) Refer to Page 120, "3.3.1 Outside dimensions" for details.  
 Note5) This controller is standard specification. (Refer to Page 115, "3.1.2 Protection specifications and operating supply".)



Note6) This indicates the section of the power supply to which the equipment is assumed to be connected between the public electrical power distribution network and the machinery within premises.

Category II applies to equipment for which electrical power is supplied from fixed facilities. The surge voltage withstand level for up to the rated voltage of 300V is 2500V.

Note7) This index indicates the degree to which conductive material is generated in terms of the environment in which the equipment is used.

Pollution level 2 is when only non-conductive pollution occurs. A temporary conductivity caused by condensing must be expected occasionally.

Note8) The robot must be grounded by the customer.

Table 3-3 : Robot CPU unit (CR800-R controller) standard specification

Item		Unit	Specification	Remarks
Type			R16RTCPU	
Interface	Addition axis synchronization	port	1	
Power source	Power capacity (DC5V)	A	1.7	
Outline dimension		mm	27.8(W) × 110(D) × 106(H)	
Mass		kg	0.3	
Ambient temperature	In use	°C	0 to 55	Without freeze
	At transport/storage		-15 to +70	
Ambient humidity	In use	%RH	5 to 95	Without dew drops
	At transport/storage		90 or less	

(3) CR800-Q controller

Use the robot CPU unit which connects to CR800-Q controller, equipping the base unit of the sequencer of the MELSEC-Q series of our company. Specifications such as the power supply and outside dimension of the robot CPU unit are the same as the sequencer's specification. Refer to Page 119 "Fig. 3-3" (Names of each part), and Page 122 "Fig. 3-6" (Outside dimensions).

Although the specification with which the robot CPU unit and the controller (box which mounts the servo amplifier for the robots, the safety circuit, etc.) were put together is shown in Table 3-4, the specification of the controller is mainly described.

Table 3-4 : Specifications of CR800-Q controller

Item	Unit	Specification	Remarks		
Type		CR800- □ VQ CR800-04VJQ CR800-07VLQ	" □ " in type name shows the load (2kg: "02", 4kg: "04", 7kg: "07", 13kg: "13", 20kg: "20") of robot arm. CR800-04VJQ controller is for RV-4FRJL only. CR800-07VLQ controller is for RV-7FRLL only.		
Number of control axis		Simultaneously 6	Additional 8 axes available.		
Memory capacity	Programmed positions	point	26,000		
	No. of steps	step	52,000		
	Number of program		512		
Robot language		MELFA-BASIC V, VI			
Teaching method		Pose teaching method, MDI method <sup>Note1)</sup>			
External input and output	Input and output	point	0/0	Multi-CPU shared device Input 8192/Output 8192 (Max.)	
	Dedicated input/output		Assign to the multi-CPU shared device.		
	Hand open/close input/output	point	4/4 (RV-2FR series) 8/8 (Other models)	The sink/source type can be switched with parameters.	
	Emergency stop input	point	1	Dual line	Category 4, Performance Level e (ISO13849-1)  Category 3, Performance Level d (ISO13849-1)
	Emergency stop output	point	1	Dual line	
	Mode selector switch input <sup>Note2)</sup>	point	1	Dual line	
	Mode output	point	1	Dual line	
	Robot error output	point	1	Dual line	
	Addition axis synchronization	point	1	Dual line	
Door switch input	point	1	Dual line		
Interface	Additional axis, force sensor interface	Channel	1	SSCNET III/H (Connect with MR-J4-B series)	
	Communication interface between robot controllers	Channel	1	Communication between robot CPU.	
	Remote input/output	Channel	1	Compatible with Ver. 2.0 (safety control)	
	Ethernet	port	1	For customer: 100BASE-T/ 100BASE-TX/10BASE-T	
			1	Dedicated T/B port: 100BASE-TX/ 10BASE-T	
	Option slot	slot	2	Only the function extension card is available.	
	SD memory card slot	slot	1	For extended memory	
RS-422	port	1	Dedicated T/B port		
Power source	Input voltage range	V	RV-2FR/4FR/7FR series: Single phase AC 200 to 230	The rate of power-supply voltage fluctuation is within 10%. Refer to the table in " ■ Introduction " for details of the robot type.	
			RV-13FR series: Single phase AC 230 Single phase AC 200 to 230		
	Power capacity	kVA	RV-2FR series: 0.5 RV-4FR series: 1.0 RV-7FR series: 2.0 RV-13FR series: 3.0	Does not include rush current. <sup>Note3)</sup> Refer to the table in " ■ Introduction " for details of the robot type.	

Item		Unit	Specification	Remarks
Power supply frequency		Hz	50/60	
Outline dimensions <sup>Note4)</sup>		mm	430(W) x 425(D) x 99.5(H)	Excluding protrusions
Mass		kg	Approx. 12.5	
Construction			Self-contained floor type, Opened type. Installation vertically or horizontally	IP20 <sup>Note5)</sup>
Ambient temperature	In use	°C	0 to 40	Without freeze
	At transport/storage		-15 to +70	
Ambient humidity	In use	%RH	45 to 85	Without dew drops
	At transport/storage		90 or less	
Overvoltage category <sup>Note6)</sup>			II or less	
Pollution level <sup>Note7)</sup>			2 or less	
Altitude		m	1000 or less	
Grounding		Ω	100 or less	100 Ω or less (class D grounding) <sup>Note8)</sup>
Paint color			Dark gray	Equivalent to Munsell: 3.5PB3.2/0.8, PANTONE: 432C

Note1) Pose teaching method: The method to register the current position of the robot arm.

MDI method: The method to register by inputting the numerical value Immediate.

Note2) Provide a mode selector switch to change the mode (MANUAL/AUTOMATIC) of the controller. Select the switch that meets the following specifications.

- The switch can be locked in each position of the selected mode.
- The selected switch position can be clearly distinguished from each other.
- Only one mode can be selected at a time.

(Recommended switch model: HA1K-2C2A-2 manufactured by IDEC. The key switch can be locked in each position by removing its key.)

The mode can be changed by other means than the selector switch.

For example, the user can use a mode change program. In the program, provide a means to lock the selected mode with a password.

Note3) The power capacity is the recommended value. The power capacity does not include the rush current when the power is turned ON. The power capacity is a guideline and the actual operation is affected by the input power voltage. Use the short circuit breaker which operates by the current leakage under the commercial frequency domain (50–60Hz). If sensitive to the high frequency ingredient, it will become the cause in which below the maximum leak current value carries out the trip.

The following lists the current values of the representative models as a reference.

Model	Item	Current [A]	Apparent power [kVA]	Voltage at measurement [V]	
RV-2FR	At control power ON	0.41	0.09	214.3	
	At servo ON	0.64	0.14	214.5	
	In automatic operation	Effective value	1.23	0.25	213.7
		Peak	4.80	0.99	214.2
RV-4FRL	At control power ON	0.41	0.09	213.6	
	At servo ON	0.93	0.20	212.0	
	In automatic operation	Effective value	2.64	0.46	212.8
		Peak	12.00	2.40	213.2
RV-7FRL	At control power ON	0.40	0.09	214.2	
	At servo ON	0.94	0.20	214.1	
	In automatic operation	Effective value	4.32	0.81	214.5
		Peak	22.50	4.65	214.9
RV-13FR (Single phase)	At control power ON	0.49	0.11	214.9	
	At servo ON	1.35	0.29	214.9	
	In automatic operation	Effective value	6.29	1.30	214.9
		Peak	22.50	4.87	214.9
RV-13FR (Three phase)	At control power ON	0.39	0.14	214.3	
	At servo ON	0.91	0.33	210.7	
	In automatic operation	Effective value	3.12	0.58	216.2
		Peak	12.11	2.25	225.0

Note4) Refer to [Page 120](#), "3.3.1 Outside dimensions" for details.

Note5) This controller is standard specification. (Refer to [Page 115](#), "3.1.2 Protection specifications and operating supply".)

Note6) This indicates the section of the power supply to which the equipment is assumed to be connected between the public electrical power distribution network and the machinery within premises.

Category II applies to equipment for which electrical power is supplied from fixed facilities. The surge voltage withstand level for up to the rated voltage of 300V is 2500V.

Note7) This index indicates the degree to which conductive material is generated in terms of the environment in which the equipment is used.

Pollution level 2 is when only non-conductive pollution occurs. A temporary conductivity caused by condensing must be expected occasionally.

Note8) The robot must be grounded by the customer.

Table 3-5 : Robot CPU unit (CR800-Q controller) standard specification

Item		Unit	Specification	Remarks
Type			Q172DSRCPU	
Interface	Addition axis synchronization	port	1	
Power source	Power capacity (DC5V)	A	1.44	
Outline dimension		mm	27.4(W) × 120.3(D) × 120.5(H)	
Mass		kg	0.38	
Ambient temperature	In use	°C	0 to 55	Without freeze
	At transport/storage		-25 to +75	
Ambient humidity	In use	%RH	5 to 95	Without dew drops
	At transport/storage		5 to 95	

### 3.1.2 Protection specifications and operating supply

#### (1) Protection specifications

A protection method complying with the IEC Standard IP20 (Opened type) is adopted for CR800 controller.

The IEC IP symbols refer only to the degree of protection between the solid and the fluids, and don't indicated that any special protection has been constructed for the prevention against oil and water.

**【Information】**

- The IEC IP20

It indicates the protective structure that prevents an iron ball  $12^{+0.05}_0$ mm diameter, which is being pressed with the power of  $3.1 \text{ kg} \pm 10\%$ , from going through the opening in the outer sheath of the supplied equipment.

#### (2) Operating supply

The controller is supposed to be installed and used in the customer's system. Supply the primary power of the controller from the system. In addition, provide a safety device (ex. earth-leakage current breaker) that can shut off the power of the controller in the customer's system. When using the earth-leakage current breaker as a safety device, select the product that meets the following specifications.

Item	Unit	Specification
Rated voltage	V	AC200 to 230
Rated sensitivity current	mA	30 or more
Rated current	A	10 or more

Refer to the section [Page 195, "6.2 Working environment"](#) for details on the working environment.

### 3.2 Names of each part

#### 3.2.1 Controller

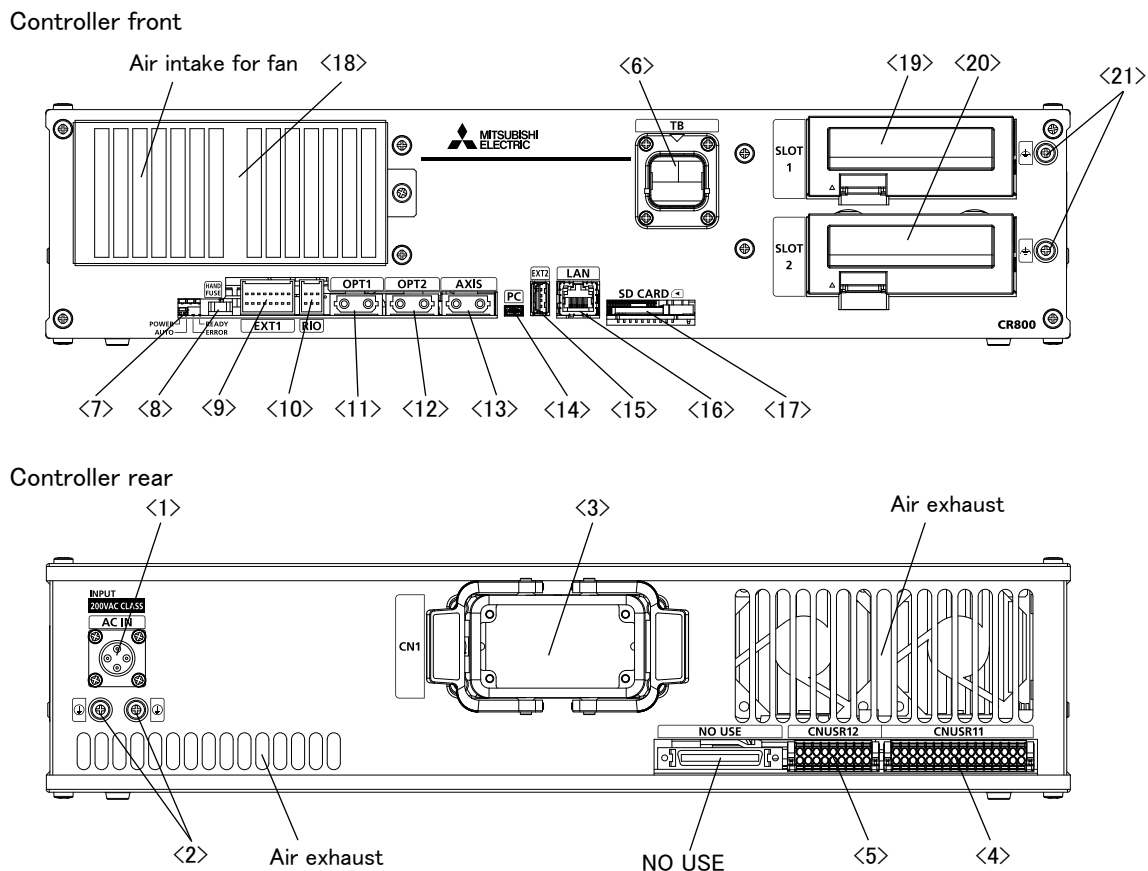

Fig.3-1 : Names of controller parts

<1> ACIN connector..... Supplied ACIN cable connector (input voltage: AC200V).  
 Refer to a separate manual “INSTRUCTION MANUAL/Controller setup, basic operation, and maintenance” for how to connect a power cable.

Number of phase	ACIN cable
Single phase	<p>Terminal: M5, cable length: 3m</p>
Three phase	<p>Terminal: M5, cable length: 3m</p>

<2> PE terminal..... Terminals for grounding (M4 screw x 2).

<3> CN1 cable..... Machine cable connector.

<4> <5> CNUSR connector..... Robot I/O cable connectors.

<4>: CNUSR11, <5>: CNUSR12

Refer to a separate manual “INSTRUCTION MANUAL/Controller setup, basic operation, and maintenance” for the connection method and the further description of pin assignment.

- <6> TB connector.....Dedicated connector for connecting T/B.
- <7> LED .....Four LEDs indicating the controller status.

LED	Details
POWER	Indicates the control power status. On: Control power ON Off: Control power OFF
AUTO	Indicates the controller mode. On: AUTOMATIC mode Off: MANUAL mode
ERROR	Indicates the error status. On: Error occurred. Rapid flashing: High-level error occurred. Off: Normal operation
READY	Indicates the operation status. On: ON (ready) Slow flashing: During operation Rapid flashing: Operation suspended.

- <8> HAND FUSE .....Fuse for the hand.
- <9> EXT1 .....Connector for function extension.
- <10> RIO.....Parallel I/O extension connector.
- <11> OPT1.....Connector for communication with another controller or the robot CPU.
- <12> OPT2.....Connector for communication with another controller.
- <13> AXIS .....Connector for additional axis connection.
- <14> PC .....Connector for communication with a personal computer. This connector cannot be used in CR800-R/CR800-Q controller.
- <15> EXT2.....Connector for function extension. This connector cannot be used in CR800-R/CR800-Q controller.
- <16> LAN.....Connector for Ethernet communication. This connector cannot be used in CR800-R/CR800-Q controller.
- <17> SD CARD .....SD memory card slot. This connector cannot be used in CR800-R/CR800-Q controller.
- <18> Filter cover .....Dustproof dust filter cover. An air filter is provided inside the filter cover.
- <19> <20>Option slot.....Option card slots (must be covered when not used).  
    <19> SLOT1, <20> SLOT2
- <21> FG terminal.....Option card cable terminals for grounding (M4 screw x 2).

 **Caution**

Use the network equipments (personal computer, USB hub, LAN hub, etc) confirmed by manufacturer. The thing unsuitable for the FA environment (related with conformity, temperature or noise) exists in the equipments connected to USB. When using network equipment, measures against the noise, such as measures against EMI and the addition of the ferrite core, may be necessary. Please fully confirm the operation by customer. Guarantee and maintenance of the equipment on the market (usual office automation equipment) cannot be performed.

3.2.2 Robot CPU unit  
 (1) CR800-R controller

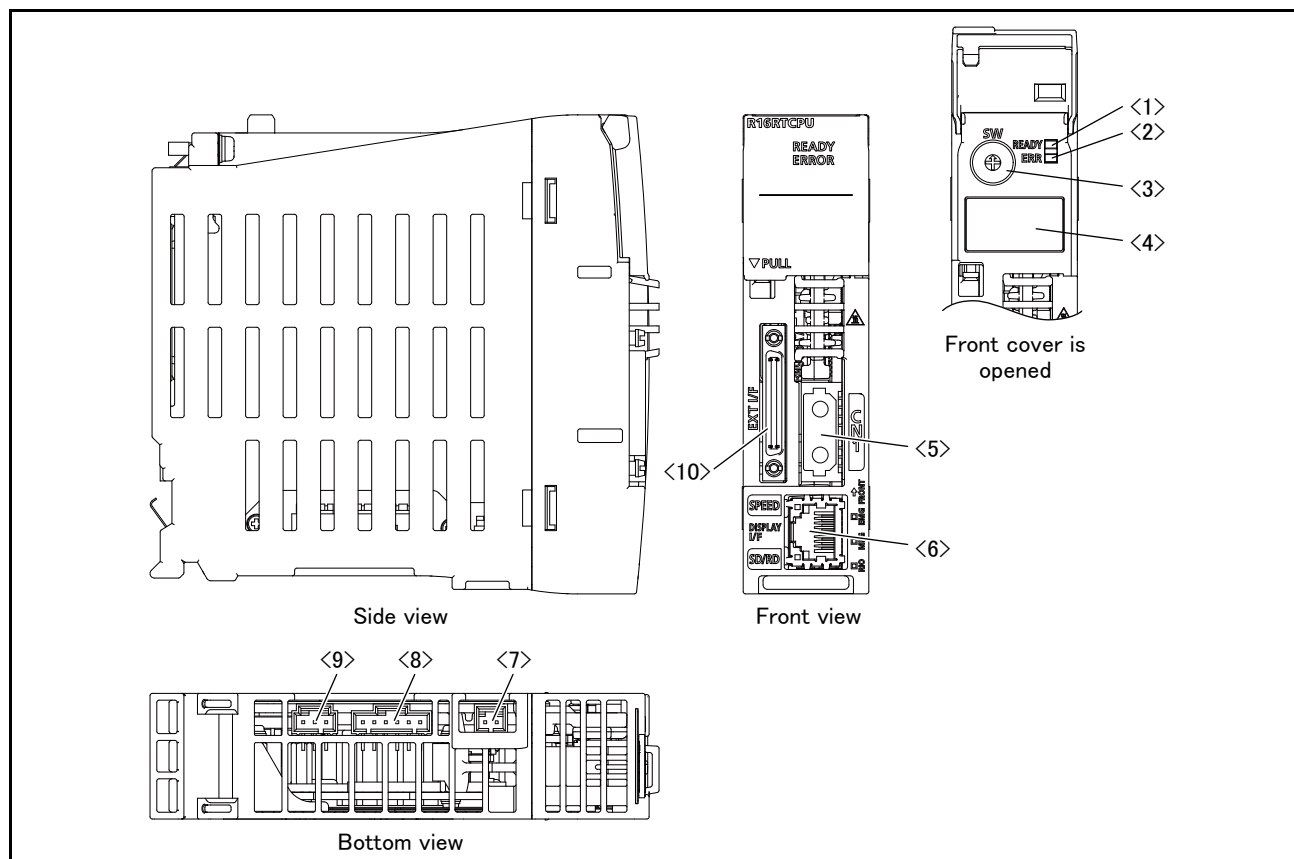

Fig.3-2 : Names of each part of the robot CPU unit (CR800-R controller)

<1> <2> LED ..... Indicators for the operation status and the error status of the robot CPU.

READY LED	ERROR LED	CPU status
OFF	ON	Power is off or a hardware error occurred.
Flashing	OFF	During initialization.
ON	OFF	Normal operation.
ON	Flashing	Moderate error occurred.
OFF	ON/flashing	Critical error occurred.

- <3> Rotary switch ..... Provided for maintenance. Always set it as "0."
- <4> Dot matrix LED..... 3-digit display indicating the operation status and error information
- <5> CN1 connector..... Connect the SSCNET III cable between the OPT1 connector on the controller and this connector.
- <6> Network connector..... Connector for Ethernet communication.
- <7> EMG connector..... Unused.
- <8> MPG connector..... Unused.
- <9> RIO connector..... Unused.
- <10> EXT I/F ..... Unused.

(2) CR800-Q controller

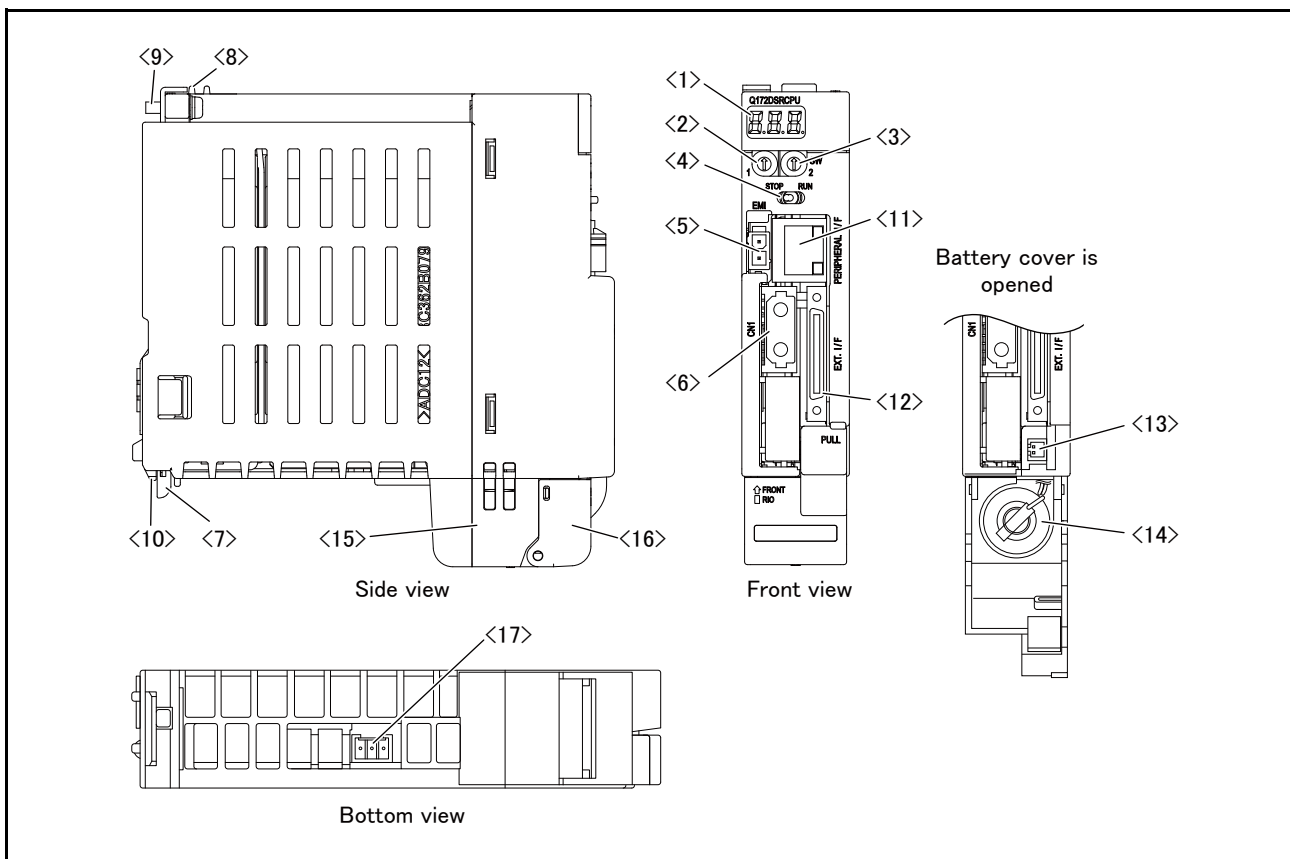

Fig.3-3 : Names of each part of the robot CPU unit (CR800-Q controller)

- <1> Seven segments LED .....Indicates operational status and error information.
- <2> Rotary switch (SW1) ..... Set up operation mode. Always set it as "0."
- <3> Rotary switch (SW2) ..... Set up operation mode. Always set it as "0."
- <4> RUN/STOP switch ..... Unused.
- <5> Emergency stop input (EMI) ..... Unused.
- <6> CN1 connector\*<sup>1)</sup> ..... Connect the SSCNET III cable to this connector and the OPT1 connector on the controller. (Connection for robot servo amplifiers)
- <7> Lever for unit installation.....Use this lever, when installing the unit in the base unit.
- <8> Hook for unit fixing\*<sup>2)</sup> ..... The hook which fixes the unit to the base unit (For the support at installation)
- <9> Unit fixing screw ..... The screw for fixing to the base unit (M3 × 13)
- <10> The projection for unit fixing ..... The projection for fixing to the base unit
- <11> PERIPHERAL I/F connector..... Connector for Ethernet communication.
- <12> EXT I/F connector..... Unused.
- <13> Battery connector..... The connector for connection with battery.
- <14> Battery\*<sup>3)</sup> ..... Battery (Q6BAT) for storing data.
- <15> Battery holder..... Compartment for the battery.
- <16> Battery cover ..... Battery holder cover.
- <17> RIO connector..... Unused.

\*1) Please store in the duct or fix the cable section near robot CPU with the bunch wire rod so that prudence of the cable is not applied to the connector section.  
 \*2) It is equipment for the support when installing the unit in the basic base unit. Please be sure to fix the unit to the basic base unit with the attached fixing screw.  
 \*3) Please be sure to use the external battery. Unless the battery cable is connected surely, the program in SRAM with a built-in robot CPU, the parameter, origin position data, etc. are not held.



### 3.3 Outside dimensions/Installation dimensions

#### 3.3.1 Outside dimensions

##### (1) Controller

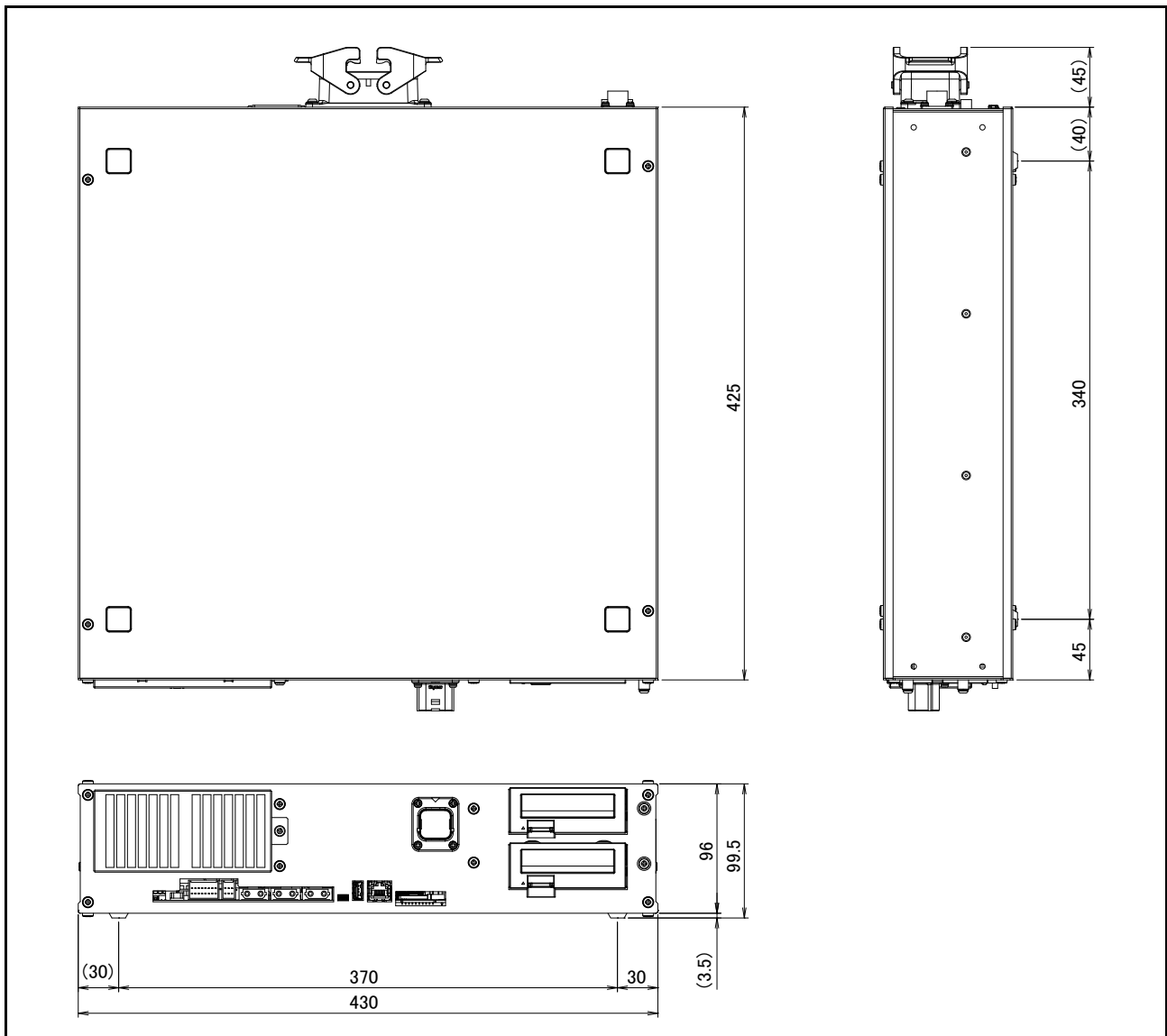

Fig.3-4 : Outside dimensions of controller

- (2) Robot CPU unit
- CR800-R controller

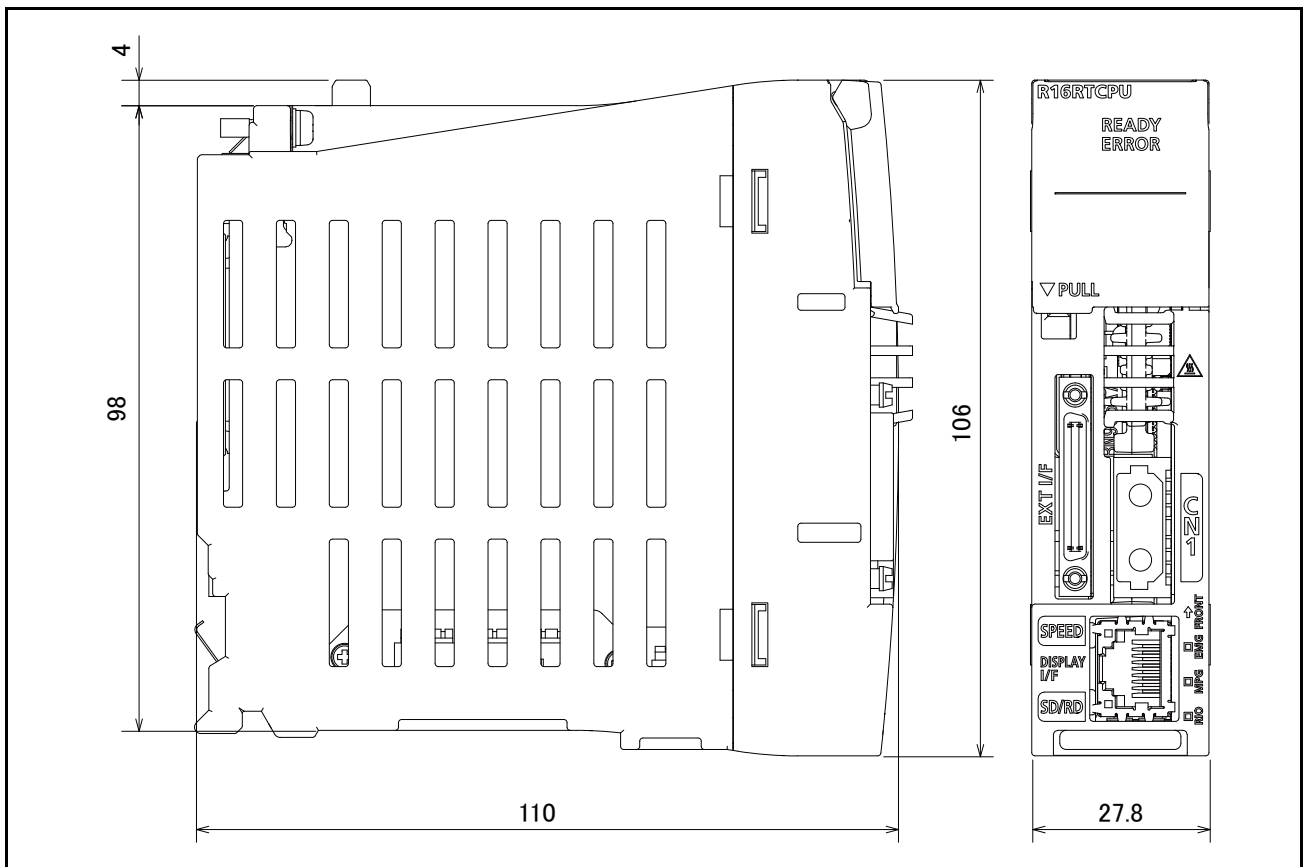

Fig.3-5 : Outside dimensions of robot CPU unit (CR800-R controller)

■ CR800-Q controller

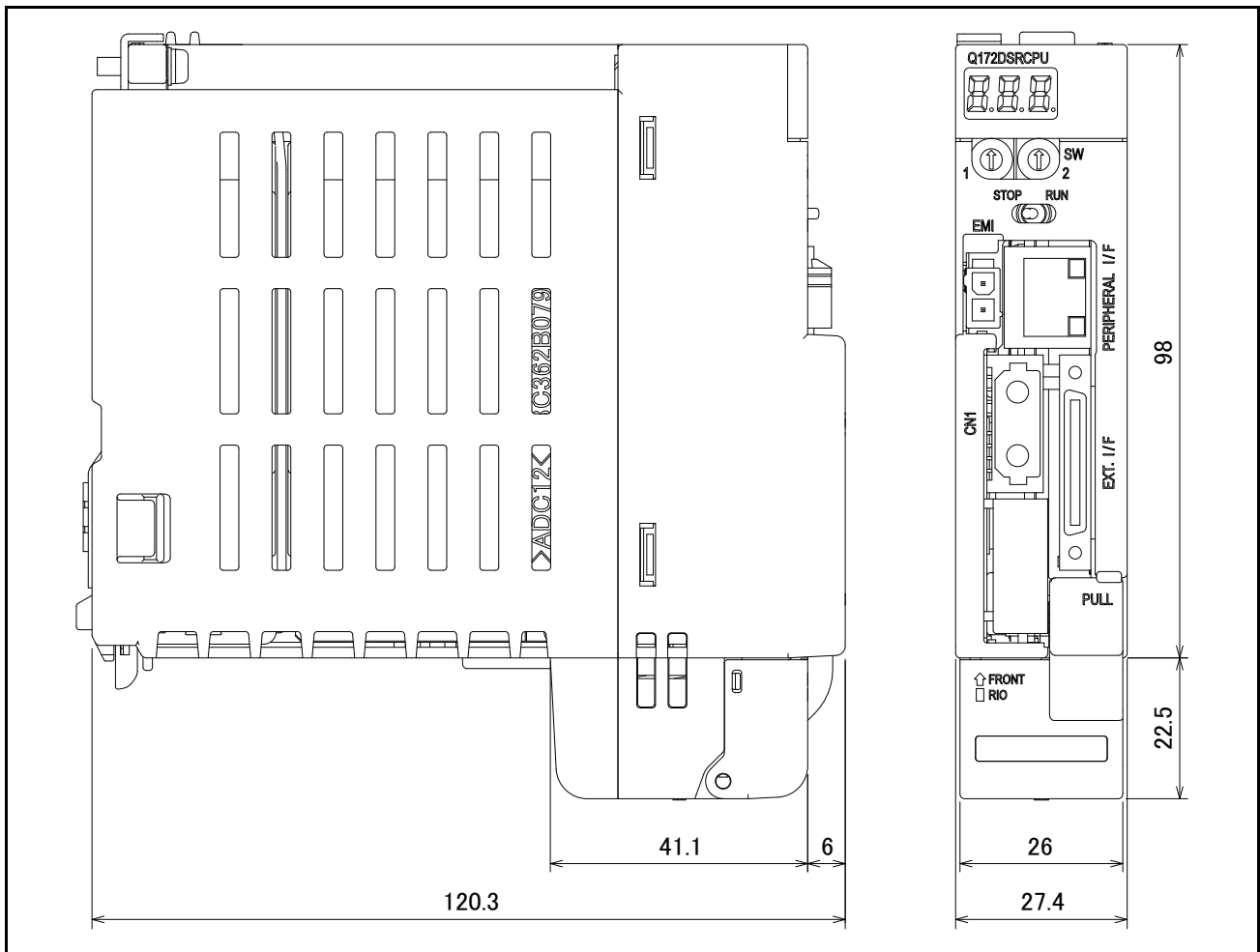

Fig.3-6 : Outside dimensions of robot CPU unit (CR800-Q controller)

### 3.3.2 Installation dimensions

#### (1) Controller

The following figures show the dimensions required installing the controller.

For the placement of the controller on its side (the horizontal installation), two stacks is permitted.

#### Horizontal installation

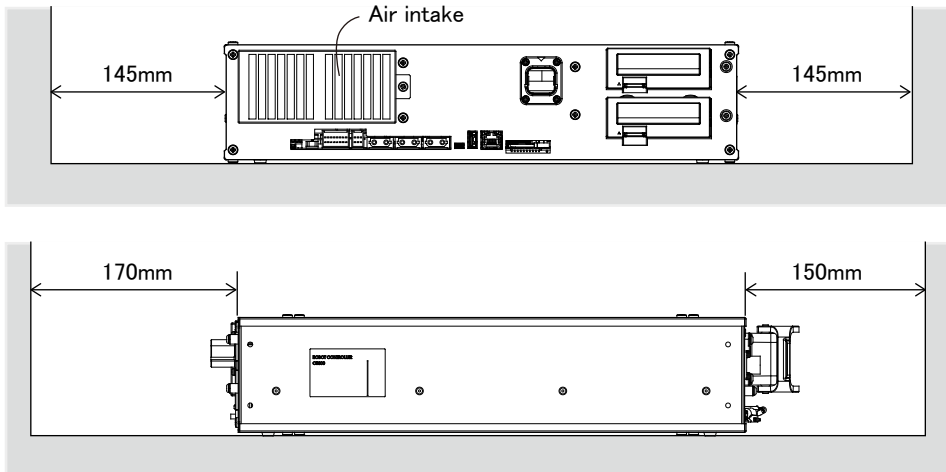

#### Vertical installation

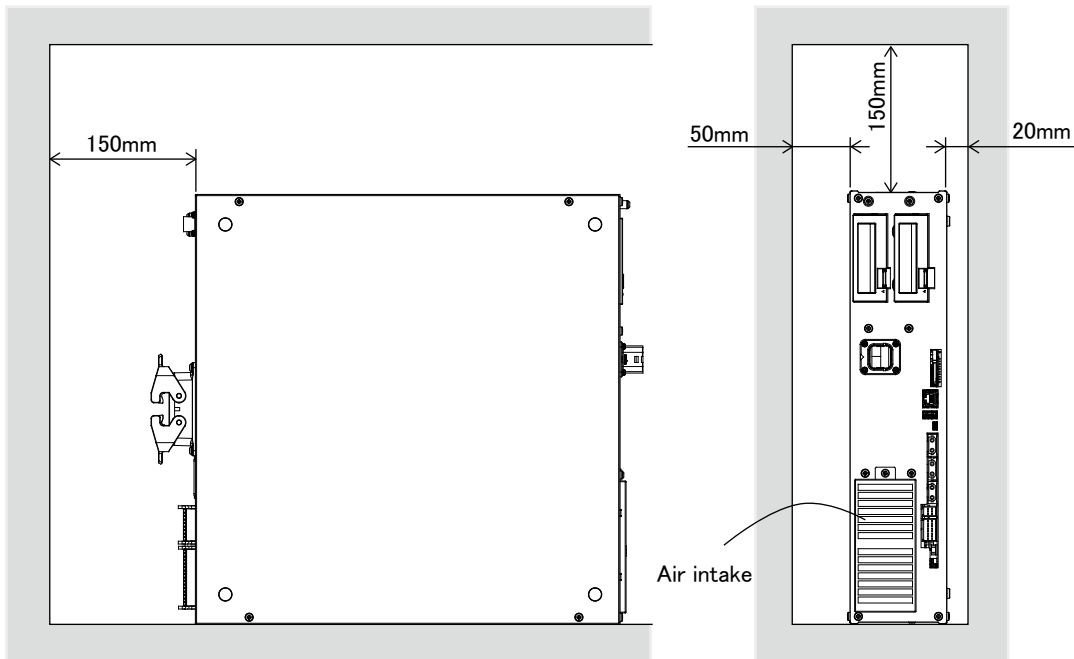

Fig.3-7 : Installation dimensions

#### **CAUTION**

Fixing installation section sure for prevention from the fall, when using the controller placing vertically. The reference figure of the metal plate for fixing is shown in [Fig. 3-8](#). You should install the metal plate for fixation to the controller with M4 x 8 or the shorter screw. The screw projection length inside the controller (side board thickness is 1.2 mm) surely makes 6.8 mm or less.

#### **CAUTION**

When storing the controller in a cabinet, etc., take special care to the heat radiating properties and ventilation properties so that the ambient temperature remains within the specification values. And, don't install the controller in the position where direct rays or the heat of lighting hits. The skin temperature of the controller may rise, and the error may occur.

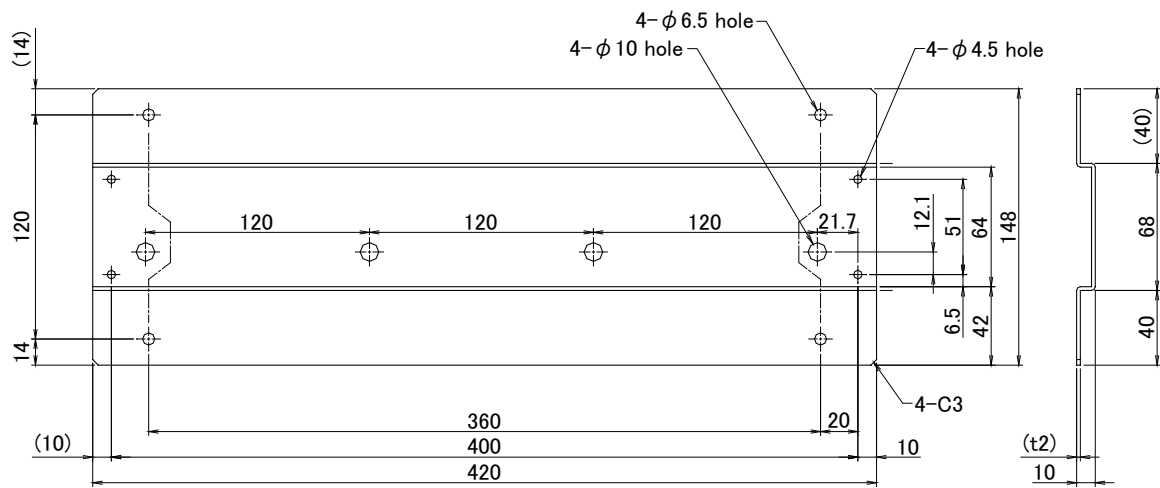

Fig.3-8 : Reference figure of the fixing metal plate for vertical installation

(2) Robot CPU unit

Because to improve ventilation and to make unit replacement easy, please secure the following distance between the upper and lower sides of the unit and the structure, etc.

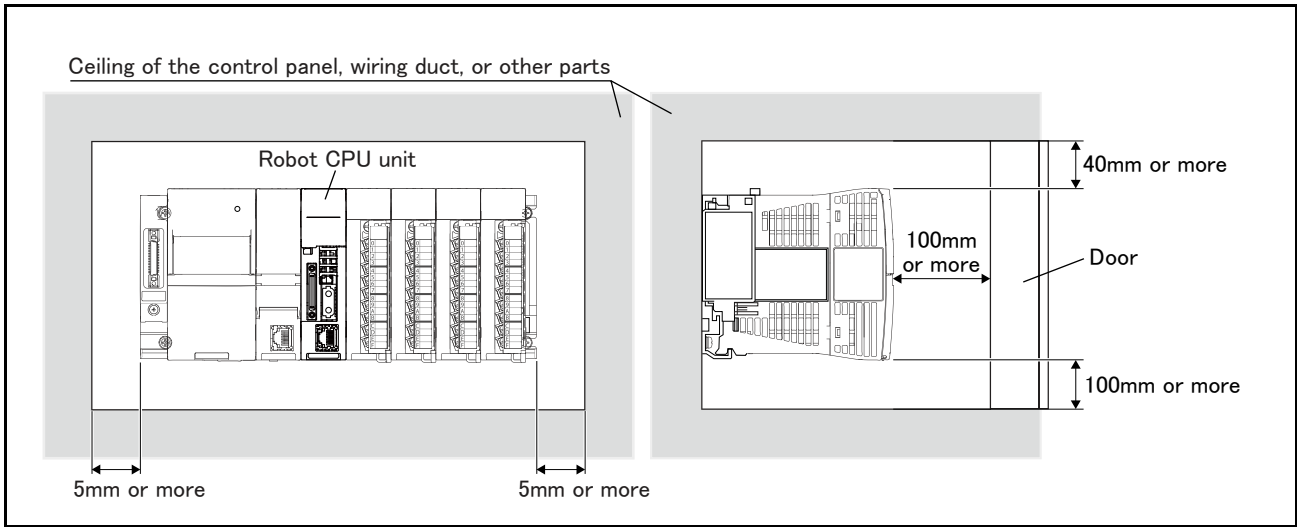

Fig.3-9 : Installation of robot CPU Unit

---

## 3.4 External input/output

### 3.4.1 Types

- (1) Dedicated input/output.....These inputs and outputs carry out the robot remote operation and status display.
- (2) General-purpose input/output.....These are inputs and outputs that the customer can program for peripheral device control.
- (3) Hand input/output.....These are inputs and outputs related to the hand that the customer can program.
- (4)Emergency stop/Door switch input.....The wiring for the safe security of the emergency stop etc. is shown in on [Page 130, "3.6 Emergency stop input and output etc."](#) and on [Page 190, "6.1.7 Examples of safety measures"](#).

<For Reference>

Linking our GOT2000 Series display equipment to the robot controller over the Ethernet permits you to control robot controller's input/output from a GOT (graphic operation terminal).

### 3.5 Dedicated input/output

Show the main function of dedicated input/output in the [Table 3-6](#). Refer to attached instruction manual "Detailed explanations of functions and operations" in the product for the other functions. Each parameter indicated with the parameter name is used by designated the signal No., assigned in the order of input signal No. and output signal No.

Table 3-6 : Dedicated input/output list

Parameter name	Input <small>Note1)</small>			Output	
	Name	Function	Level	Name	Function
TEACHMD	None			Teaching mode output signal	Outputs that the teaching mode is entered.
ATTOPMD	None			Automatic mode output signal	Outputs that the automatic mode is entered.
ATEXTMD	None			Remote mode output signal	Outputs that the remote mode is entered.
RCREADY	None			Controller power ON complete signal	Outputs that external input signals can be received.
AUTOENA	Automatic operation enabled input signal	Allows automatic operation.	L	Automatic operation enabled output signal	Outputs the automatic operation enabled state.
START	Start input signal	Starts all slots.	E	Operating output signal	Outputs that the slot is operating.
STOP	Stop input signal	Stops all slots. The input signal No. is fixed to 0. Note) Use the emergency stop input for stop inputs related to safety.	L	Wait output signal	Outputs that the slot is temporarily stopped.
STOP2	Stop input signal	The program during operation is stopped. Unlike the STOP parameter, change of the signal number is possible. Notes) Specification is the same as the STOP parameter.	L	Wait output signal	Outputs that the slot is temporarily stopped. Notes) Specification is the same as the STOP parameter.
SLOTINIT	Program reset input signal	Resets the wait state.	E	Program selection enabled output signal	Outputs that the slot is in the program selection enabled state.
ERRRESET	Error reset input signal	Resets the error state.	E	Error occurring output signal	Outputs that an error has occurred.
CYCLE	Cycle stop input signal	Carries out cycle stop.	E	In cycle stop operation output signal	Outputs that the cycle stop is operating.
SRVOFF	Servo ON enabled input signal	Turns the servo OFF for all mechanisms.	L	Servo ON enabled output signal	Outputs servo-on disable status. (Echo back)
SRVON	Servo ON input signal	Turns the servo ON for all mechanisms.	E	In servo ON output signal	Outputs the servo ON state.
IOENA	Operation rights input signal	Requests the operation rights for the external signal control.	L	Operation rights output signal	Outputs the operation rights valid state for the external signal control.
MELOCK	Machine lock input signal	Sets/resets the machine lock state for all mechanisms.	E	In machine lock output signal	Outputs the machine lock state.
SAFEPOS	Evasion point return input signal	Requests the evasion point return operation.	E	In evasion point return output signal	Outputs that the evasion point return is taking place.
OUTRESET	General-purpose output signal reset	Resets the general-purpose output signal.	E	None	
EMGERR	None			Emergency stop output signal	Outputs that an emergency stop has occurred.
S1START : S32START	Start input	Starts each slot.	E	In operation output	Outputs the operating state for each slot.



Parameter name	Input			Output	
	Name	Function	Level	Name	Function
S1STOP : S32STOP	Stop input	Stops each slot.	L	In wait output	Outputs that each slot is temporarily stopped.
PRGSEL	Program selection input signal	Designates the setting value for the program No. with numeric value input signals.	E	None	
OVRDSEL	Override selection input signal	Designates the setting value for the override with the numeric value input signals.	E	None	
IODATA Note2)	Numeric value input (start No., end No.)	Used to designate the program name, override value., mechanism value.	L	Numeric value output (start No., end No.)	Used to output the program name, override value., mechanism No.
PRGOUT	Program No. output request	Requests output of the program name.	E	Program No. output signal	Outputs that the program name is being output to the numeric value output signal.
LINEOUT	Line No. output request	Requests output of the line No.	E	Line No. output signal	Outputs that the line No. is being output to the numeric value output signal.
OVRDOUT	Override value output request	Requests the override output.	E	Override value output signal	Outputs that the override value is being output to the numeric value output signal.
ERROUT	Error No. output request	Requests the error No. output.	E	Error No. output signal	Outputs that the error No. is being output to the numeric value output signal.
JOGENA	Jog valid input signal	Validates jog operation with the external signals	E	Jog valid output signal	Outputs that the jog operation with external signals is valid.
JOGM	Jog mode input 2-bit	Designates the jog mode.	L	Jog mode output 2-bit	Outputs the current jog mode.
JOG+	Jog feed + side for 8-axes	Requests the + side jog operation.	L	None	
JOG-	Jog feed - side for 8-axes	Requests the - side jog operation.	L	None	
HNDCTRL1 : HNDCTRL3	None			Mechanism 1 hand output signal status : Mechanism 3 hand output signal status	Mechanism 1: Outputs the status of general-purpose outputs 900 to 907. Mechanism 2: Outputs the status of general-purpose outputs 910 to 917. Mechanism 3: Outputs the status of general-purpose outputs 920 to 927.
HNDSTS1 : HNDSTS3	None			Mechanism 1 hand input signal status : Mechanism 3 hand input signal status	Mechanism 1: Outputs the status of hand inputs 900 to 907. Mechanism 2: Outputs the status of hand inputs 910 to 917. Mechanism 3: Outputs the status of hand inputs 920 to 927.
HNDERR1 : HNDERR3	Mechanism 1 hand error input signal : Mechanism 3 hand error input signal	Requests the hand error occurrence.	L	Mechanism 1 hand error output signal : Mechanism 3 hand error output signal	Outputs that a hand error is occurring.
AIRERR1 : AIRERR3	Pneumatic pressure error 1 input signal : Pneumatic pressure error 3 input signal	Request the pneumatic pressure error occurrence.	L	Pneumatic pressure error 1 output signal. : Pneumatic pressure error 3 output signal.	Outputs that a pneumatic pressure error is occurring.

Parameter name	Input <span style="float: right;">Note1)</span>			Output	
	Name	Function	Level	Name	Function
M1PTEXC : M3PTEXC	None		L	Maintenance parts replacement time warning signal	Outputs that the maintenance parts have reached the replacement time.
USER-AREA <sup>Note3)</sup>	None			User-designated area 8-points	Outputs that the robot is in the user-designated area.

Note1) The level indicates the signal level.

L: Level signal → The designated function is validated when the signal is ON, and is invalidated when the signal is OFF.

E: Edge signal → The designated function is validated when the signal changes from the OFF to ON state, and the function maintains the original state even when the signal then turns OFF.

Note2) Four elements are set in the order of input signal start No., end No., output signal start No. and end No.

Note3) Up to eight points can be set successively in order of start output signal No. and end output signal No.

### 3.6 Emergency stop input and output etc.

Do wiring of the external emergency stop, the special stop input, the door switch, and the mode selector switch from the "special input/output" terminal connector.

Table 3-7 : Special input/output terminal

Item	Name	Function
Input	Emergency stop	Applies the emergency stop. Dual line, normal close
Input	Special stop input	Applies the stop. (Refer to <a href="#">Page 134</a> , "3.6.2 Special stop input (SKIP)")
Input	Door switch	Servo-off. Dual line, normal close ( <a href="#">Page 135</a> , "3.6.3 Door switch function")
Input	Mode selector switch	Changes the mode (MANUAL/AUTOMATIC) of the controller. Dual line ( <a href="#">Page 135</a> , "3.6.4 Mode selector switch function")
Output	Robot error output	Contact is opening during error occurrence.
Output	Emergency stop output	The point of contact opens under occurrence of emergency stop of external input signal, emergency stop of T/B.
Output	Mode output	MANUAL mode: contactor is opening, AUTOMATIC mode: contactor is closing.
Output	Magnet contactor control connector output for addition axes	When an additional axis is used, the servo ON/OFF status of the additional axis can be synchronized with the robot arm. ( <a href="#">Page 141</a> , "3.8 Magnet contactor control connector output (AXMC) for addition axes")

\*At the time of the power supply OFF, the output point of contact is always open.

[Note] Wire for each input terminal as shown in [Fig. 3-11](#).

The contact capacity of each input/output terminal is DC24V/100mA. Do not connect the equipment except for this range. The use exceeding contact capacity causes failure.

In the customer's system, do not ground the + side of 24V power supply prepared by customer for connect to the controller. (related with emergency stop and parallel input/output) If it connects with the controller under the condition that the + side is grounded, it will lead to failure of controller.

[Note] If a stop signal or servo OFF signal is input simultaneously with a door switch open/emergency stop input, the error, H056n "Servo sys. error (A/D)" may occur.

When a door switch open/emergency stop is input, the robot turns off the servo after it stops. It is unnecessary to input a stop signal or servo OFF signal. To input a stop signal or servo OFF signal with a door switch open/emergency stop input, wait for 100ms or more after a door switch open/emergency stop input.

Pin number assignment of each terminal and the circuit diagram are shown in [Fig. 3-11](#).

#### 3.6.1 Connection of the external emergency stop and mode selector switch

The input terminals for the external emergency stop, door switch, and mode selector switch are arranged as shown in [Fig. 3-11](#). Customers should be sure to prepare the external emergency stop, door switch, and mode selector switch, etc. and use the robot while these are connected. Connection procedures are shown below. In addition, refer to [Page 190](#), "6.1.7 Examples of safety measures" for the information on the emergency stop connection and cautions.

[Caution] The emergency stop circuit is duplicated inside the controller. The emergency stop switch uses a double contact-type switch, so please be sure to fix both of the contacts to the connector pins as shown below in order to ensure the wiring is duplicated. An error will continue to occur in the event that only one of the pins is connected.

- 1) Please prepare the emergency stop switch, door switch, and mode selector switch.
- 2) Connect the contacts of each switch to the contacts as shown below:
  - a) External emergency stop switch  
CNUSR11 connector "between 7 and 23" and "between 14 and 30".
  - b) Door switch  
CNUSR11 connector "between 6 and 22" and "between 13 and 29".
  - c) Mode selector switch  
CNUSR11 connector "between 5 and 21" and "between 12 and 28".

[Caution] Be sure to use a shield cable for the emergency stop wiring cable and dedicated stop input wiring cable. And when operating in an environment that is easily affected by noise, be sure to install the ferrite core (recommended model name: E04SR301334, manufacturer: Seiwa Electric Mfg. Co., Ltd.). Be sure to place the ferrite core in 300mm or less from the connecting terminal section.

**CAUTION** Make sure there are no mistakes in the wiring. Connecting differently to the way specified in the manual can result in errors, such as the emergency stop not being released. In order to prevent errors occurring, please be sure to check that all functions (such as the teaching box emergency stop, customer emergency stop, and door switch) are working properly after the wiring setup is completed.

**CAUTION** You should always connect doubly connection of the emergency stop, the door switch, and the mode selector switch. In connection of only one side, if the relay of customer use should break down, it may not function correctly. And, the output contacts from the robot controller (robot error output, emergency stop output, mode output, addition axis contactor control output) are dual contacts (synchronizes). You should connect surely by dual line with the customer's equipment as well as connection of the emergency stop and the door switch.

**CAUTION** Please make sure to wire the multiple emergency stop switches so that they each function independently. Check and make sure that the emergency stop doesn't only function under an AND condition (when multiple emergency stop switches are ON at the same time).

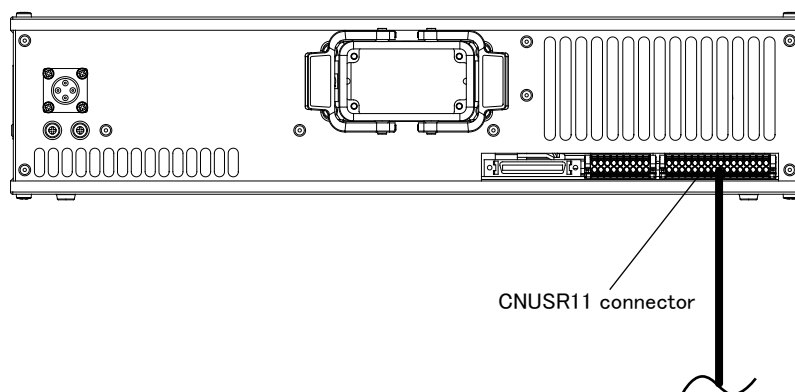

Fig.3-10 : Emergency stop cable and mode selector switch connection

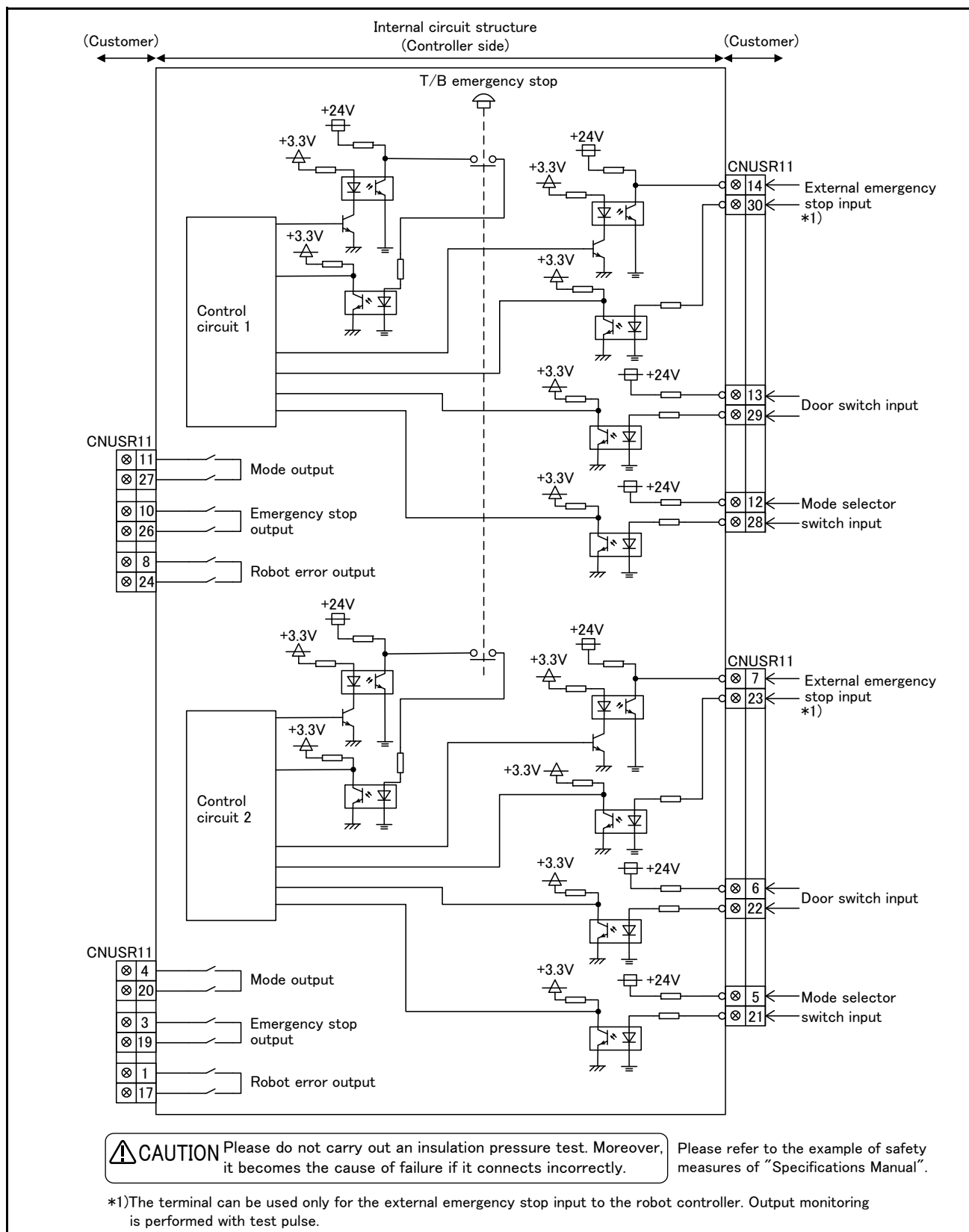

Fig.3-11 : External emergency stop connection

**CAUTION**

Place the emergency stop switch in an easily operable position, and be sure to wire it to the emergency stop correctly by referencing [Page 190, "6.1.7 Examples of safety measures"](#). This is a necessary measure in order to ensure safe operation so that the robot can be stopped immediately by pressing the emergency stop switch in the event that the robot malfunctions.

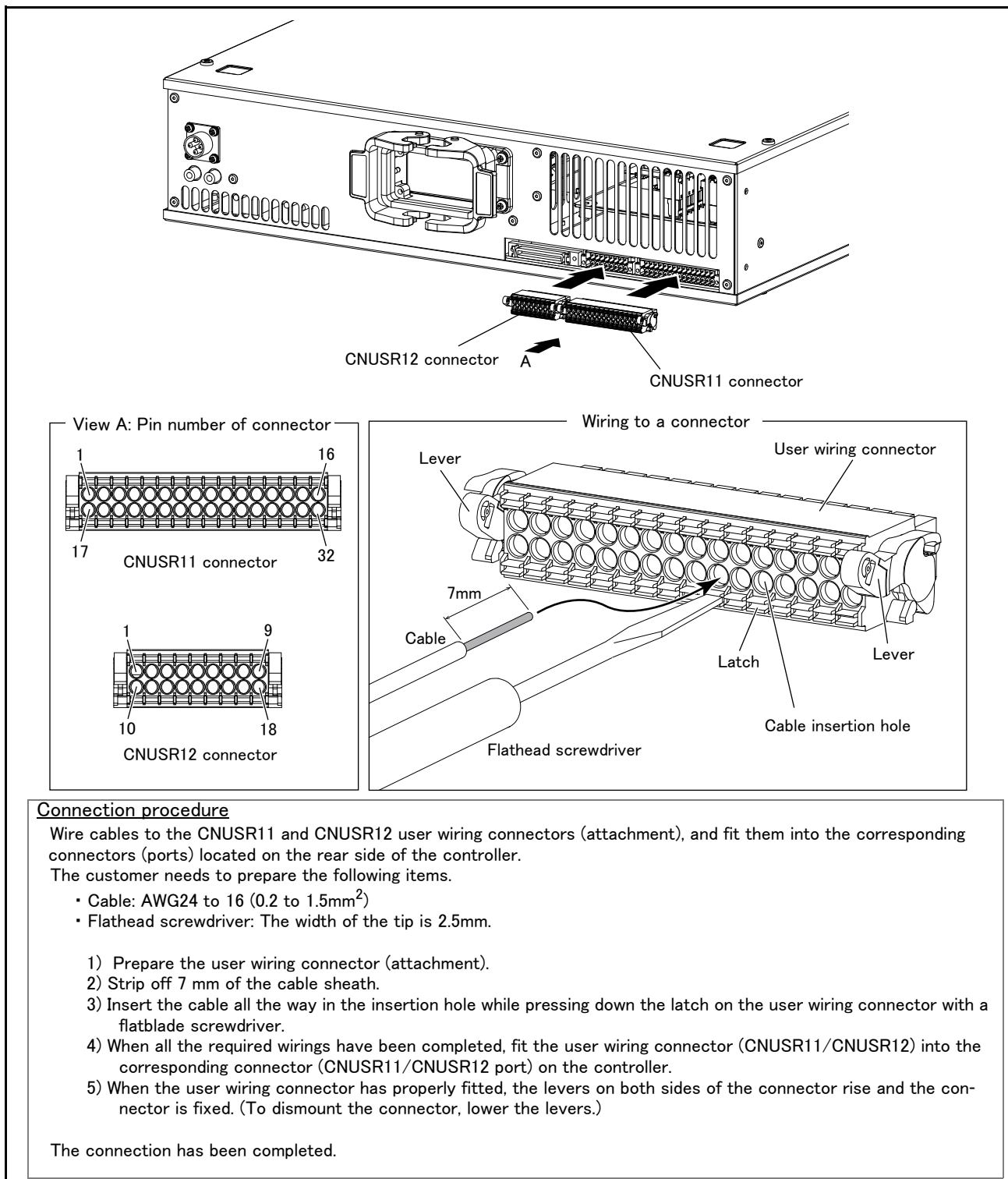

Fig.3-12 : Wiring method to the user wiring connector

**CAUTION**

Fully check the number of the cable insertion hole (connector pin number) for incorrect connection. Incorrect wiring may damage the robot or cause a malfunction.

**CAUTION**

When wiring to the CNUSR11/CNUSR12 connector, pay attention to fraying wires of the core wires. The fraying wires can come into contact with the adjacent terminal, causing a short circuit.

Do not apply solder on core wires. Doing so may cause a contact failure.

### 3.6.2 Special stop input (SKIP)

The SKIP is the input signal to stop the robot. Please connect the pin 4, 13 of the CNUSR12 connector shown in Fig. 3-13.

Table 3-8 : Special stop input electric specification

Item	Specifications	Internal circuit	
Type	DC input		
No. of input point	1		
Insulation method	Photo-coupler insulation		
Rated input voltage	DC24V		
Rated input current	Approx. 11mA		
Working voltage range	DC 21.6 ~ 26.4V (Ripple rate within 5%)		
ON voltage/ON current	DC 8V or more / 2mA or more		
OFF voltage/OFF current	DC 4V or less / 1mA or less		
Input resistance	Approx. 2.2 k $\Omega$		
Response time	OFF $\rightarrow$ ON		1ms or less
	ON $\rightarrow$ OFF		1ms or less
Common method	1 point per common		
External wire connection method	Connector		

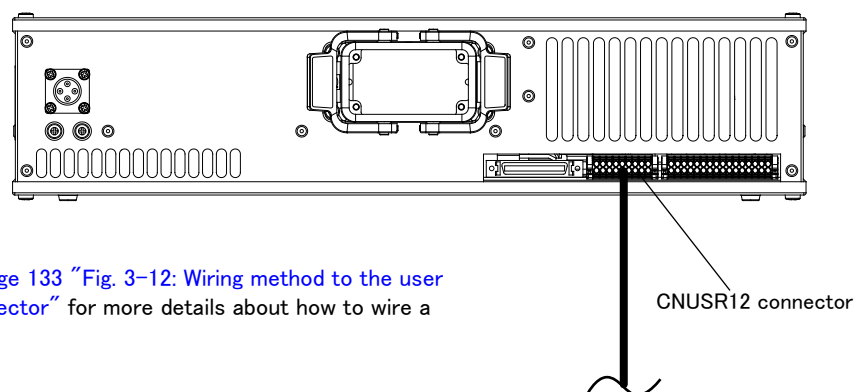

\* Refer to Page 133 "Fig. 3-12: Wiring method to the user wiring connector" for more details about how to wire a connector.

Note) In the customer's system, do not ground the + side of 24V power supply prepared by customer for connect to the controller. (related with emergency stop and parallel input/output) If it connects with the controller under the condition that the + side is grounded, it will lead to failure of controller.

Fig.3-13 : Connection of the special-stop-input

### 3.6.3 Door switch function

This function acquires the status of the switches attached on the door of the safety fence, and it turns OFF the servo to stop the robot when the door is opened. Perform wiring so that the contact opens when the door is opened.

Follow the wiring example shown in [Page 132 "Fig. 3-11: External emergency stop connection"](#) and [Page 190, "6.1.7 Examples of safety measures"](#). Details of this function according to the robot status are shown below (Fig. 3-14).

\*During automatic operation .....When the door is opened, the servo turns OFF and the robot stops. An error occurs. The process of the restoration: Close the door, reset the alarm, turn on the servo, and restart.

\*During teaching.....Even when the door is opened, using a selector switch allows to turn the servo ON with the teaching pendant to operate the robot.

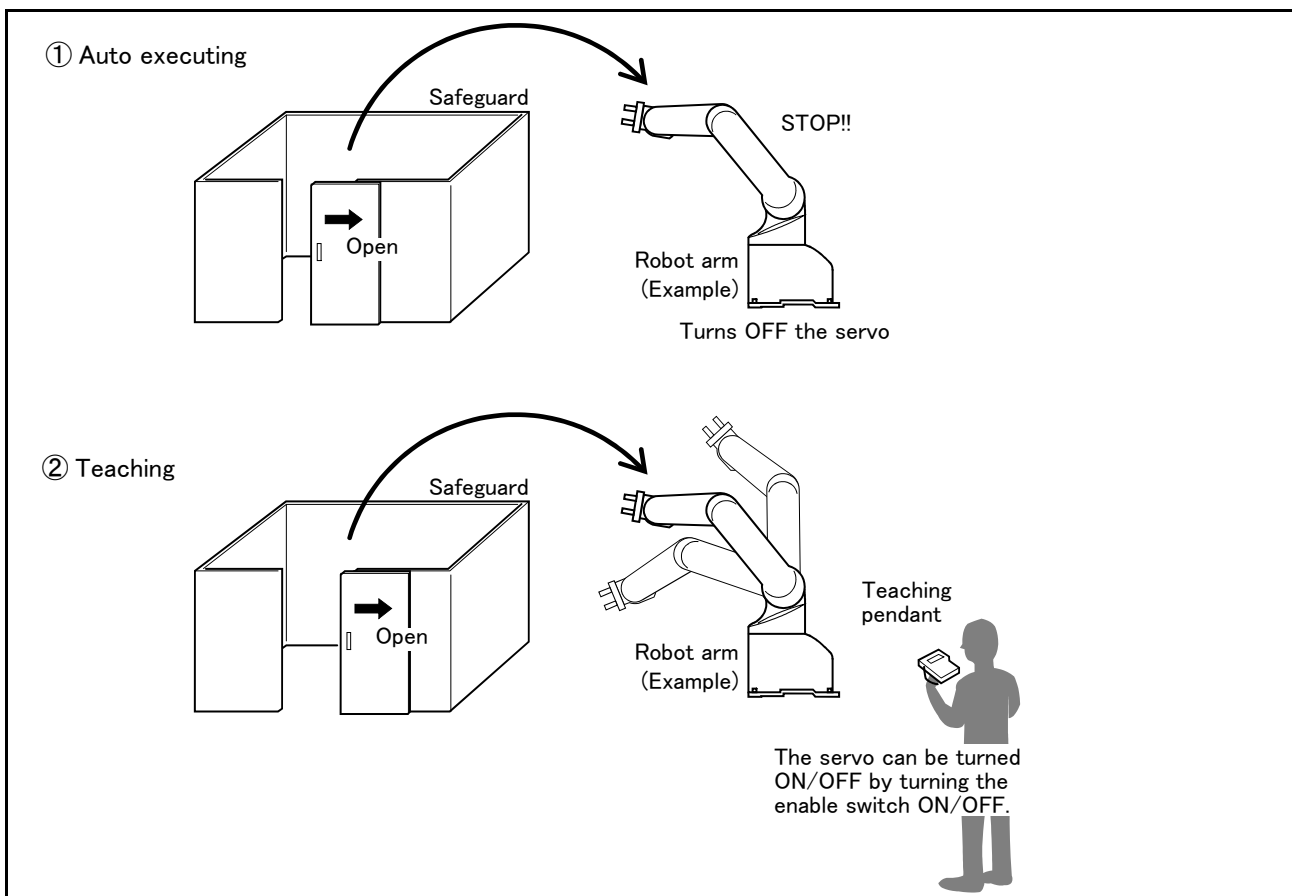

Fig.3-14 : Door switch function

### 3.6.4 Mode selector switch function

The mode selector switch switches the mode of the controller between MANUAL mode and AUTOMATIC mode.

Table 3-9 : States of input terminal

Mode of controller	Input terminal
MANUAL (Teaching)	Open
AUTOMATIC (Automatic operation)	Close



## (1) Automatic Operation/Jog Operation/Brake Release and Necessary Switch Settings

The following is a description of various operations performed on the robot and switch settings that are required.

Table 3-10 : Various operations and necessary switch settings

No	Operation	Related switch settings <sup>Note1)</sup>				Description
		T/B enable/disable	T/B enable switch	Mode selector switch input terminal	Door switch input terminal	
1	Jog operation	Enable	ON	Open (MANUAL mode)	—	If the mode selector switch input is set to Open (MANUAL mode), the state of door switch input does not matter.
3	Brake release <sup>Note2)</sup>	Enable	ON	Open (MANUAL mode)	—	If the mode selector switch input is set to Open (MANUAL mode), the state of door switch input does not matter.
4	Automatic operation	Disable	—	Close (AUTOMATIC mode)	Close (Door Close)	Door switch input must always be in a state of Close (Door Close).

Note1) “—” in the table indicates that the state of switch concerned does not matter.

Refer to the following for operation of each switch.

- T/B enable/disable:.....Page 144, “(1) Teaching pendant (T/B)”
- T/B enable switch: .....Page 144, “(1) Teaching pendant (T/B)”
- Mode selector switch input terminal:.....Page 190, “6.1.7 Examples of safety measures”
- Door switch input terminal: .....Page 190, “6.1.7 Examples of safety measures”

Note2) T/B is used for the brake release operation. Brake release can be effected only when the T/B enable switch is placed in intermediate position (lightly gripped position). At this point, the state of door switch input does not matter.

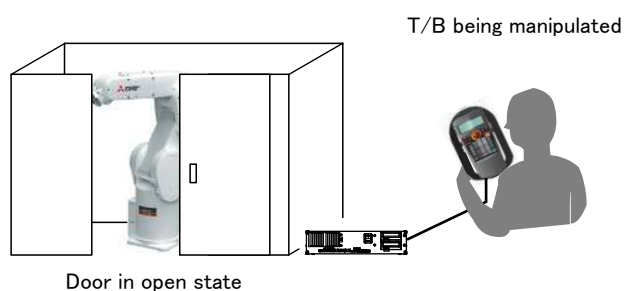

### ⚠ CAUTION

Upon the release of brake, the robot arm may fall under its own weight depending on the axis which has been released. To ensure safety, take appropriate measures such as supporting the axis to avoid the free fall.

Fig.3-15 : Brake release operation

### 3.7 Additional Axis Function

This controller is equipped with an additional axis interface for controlling an additional axis when a traveling axis or rotary table is added to the robot. A maximum of eight axes of servo motors can be controlled at the same time by connecting a general-purpose servo amplifier (MR-J4-B series) that supports Mitsubishi's SSCNET III. Refer to the separate "Additional axis interface Instruction Manual" for details on the additional axis function.

#### 3.7.1 Wiring of the Additional Axis Interface

Table 3-11 shows the connectors for additional axes inside the controller.  
 Fig. 3-16 shows a connection example (configuration example).

Table 3-11 : Dedicated connectors inside the controller

Name	Connector name	Details
Connector for additional axes	AXIS	The connector for connecting the general-purpose servo amplifier.

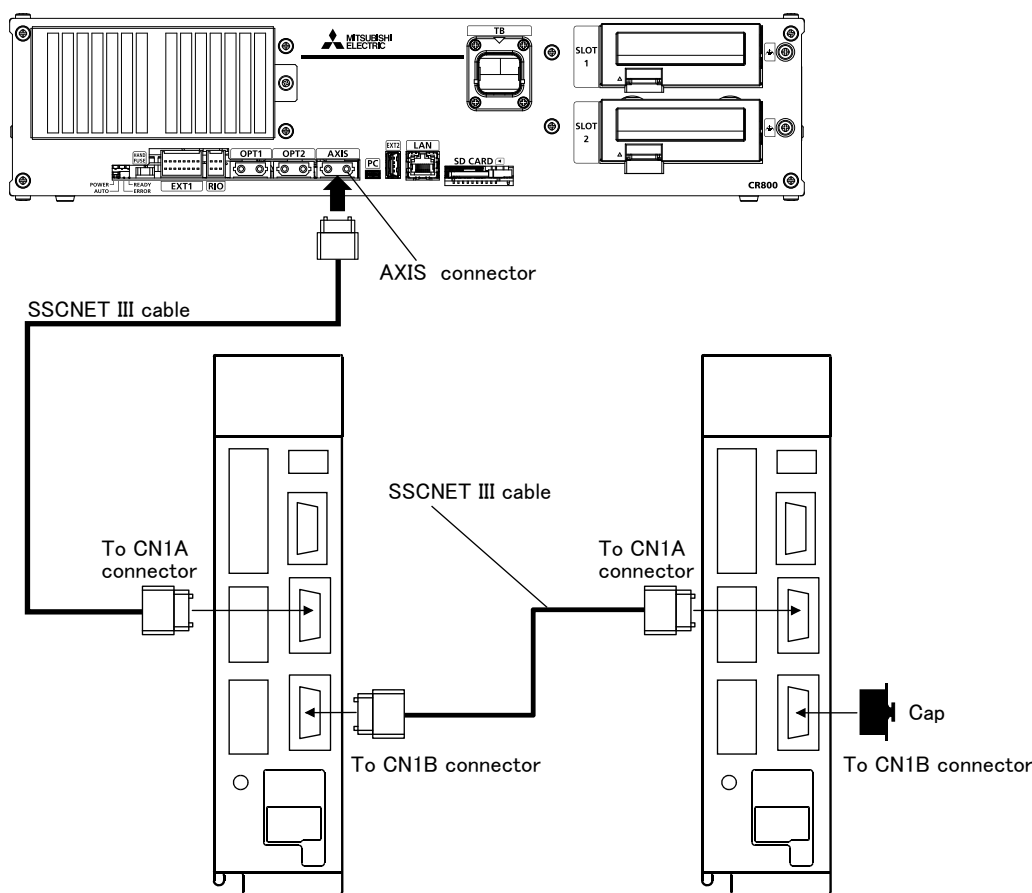

\* It cannot communicate, if connection of CN1A and CN1B is mistaken.

Fig.3-16 : Example of addition axis connection

## 3.7.2 Example of the installation of the noise filter

## ■ EMC filter (recommended)

Please install the recommendation filter shown below according to the example of connection.

Table 3-12 : Combination of a servo amplifier and filter (Soshin Electric)

Servo amplifier	Recommended filter (Soshin Electric)				Mass [kg]
	Model	Rated current [A]	Rated voltage [VAC]	Leakage current [mA]	
MR-J4-10B(-RJ) to MR-J4-100B(-RJ)	HF3010A-UN <sup>Note1)</sup>	10	250	5	3.5
MR-J4-200B(-RJ) MR-J4-350B(-RJ)	HF3030A-UN <sup>Note1)</sup>	30			5.5
MR-J4-500B(-RJ) MR-J4-700B(-RJ)	HF3040A-UN <sup>Note1)</sup>	40		6.5	6
MR-J4-11KB(-RJ) MR-J4-15KB(-RJ) MR-J4-22KB(-RJ)	HF3100A-UN <sup>Note1)</sup>	100			12
MR-J4-60B4(-RJ) MR-J4-100B4(-RJ)	TF3005C-TX	5	500	5.5	6
MR-J4-200B4(-RJ) MR-J4-700B4(-RJ)	TF3020C-TX	20			
MR-J4-11KB4(-RJ)	TF3030C-TX	30			7.5
MR-J4-15KB4(-RJ)	TF3040C-TX	40			12.5
MR-J4-22KB4(-RJ)	TF3060C-TX	60			
MR-J4-10B1(-RJ) to MR-J4-40B1(-RJ)	TF3010A-UN <sup>Note1)</sup>	10	250	5	3.5

Note1) Following surge protector is separately required to use any of these EMC filters.  
RSPD-250-U4 (Manufacture: OKAYA Electric Industries CO., Ltd.)

Table 3-13 : Combination of a servo amplifier and filter (COSEL)

Servo amplifier	Recommended filter (COSEL)				Mass [kg]
	Model	Rated current [A]	Rated voltage [VAC]	Leakage current [mA]	
MR-J4-11KB(-RJ) to MR-J4-22KB(-RJ)	FTB-100-355-L <sup>Note1)</sup>	100	500	40	5.3
MR-J4-22KB4(-RJ)	FTB-80-355-L <sup>Note1)</sup>	80	500	80	5.3

Note1) Following surge protector is separately required to use any of these EMC filters.  
RSPD-500-U4 (Manufacture: OKAYA Electric Industries CO., Ltd.)

■ Installing an EMC noise filter

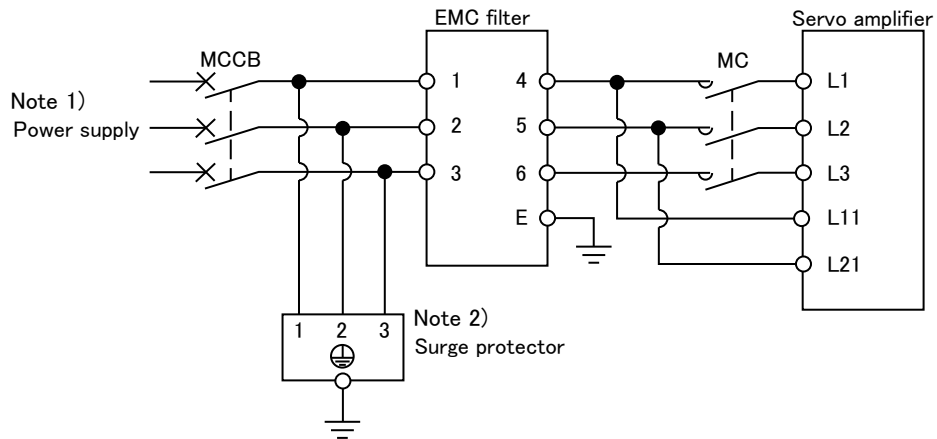

- Note 1) For 1-phase 200V to 230VAC power supply, connect the power supply to L1, L2 and leave L3 open.  
There is no L3 for 1-phase 100 to 120 VAC power supply.
- Note 2) The example is when a surge protector is connected.

Fig.3-17 : Example of EMC noise filter installation

## (1) Line noise filter

This filter is effective in suppressing noises radiated from the power supply side and output side of the servo amplifier and also in suppressing high-frequency leakage current (zero-phase current) especially within 0.5MHz to 5MHz band.

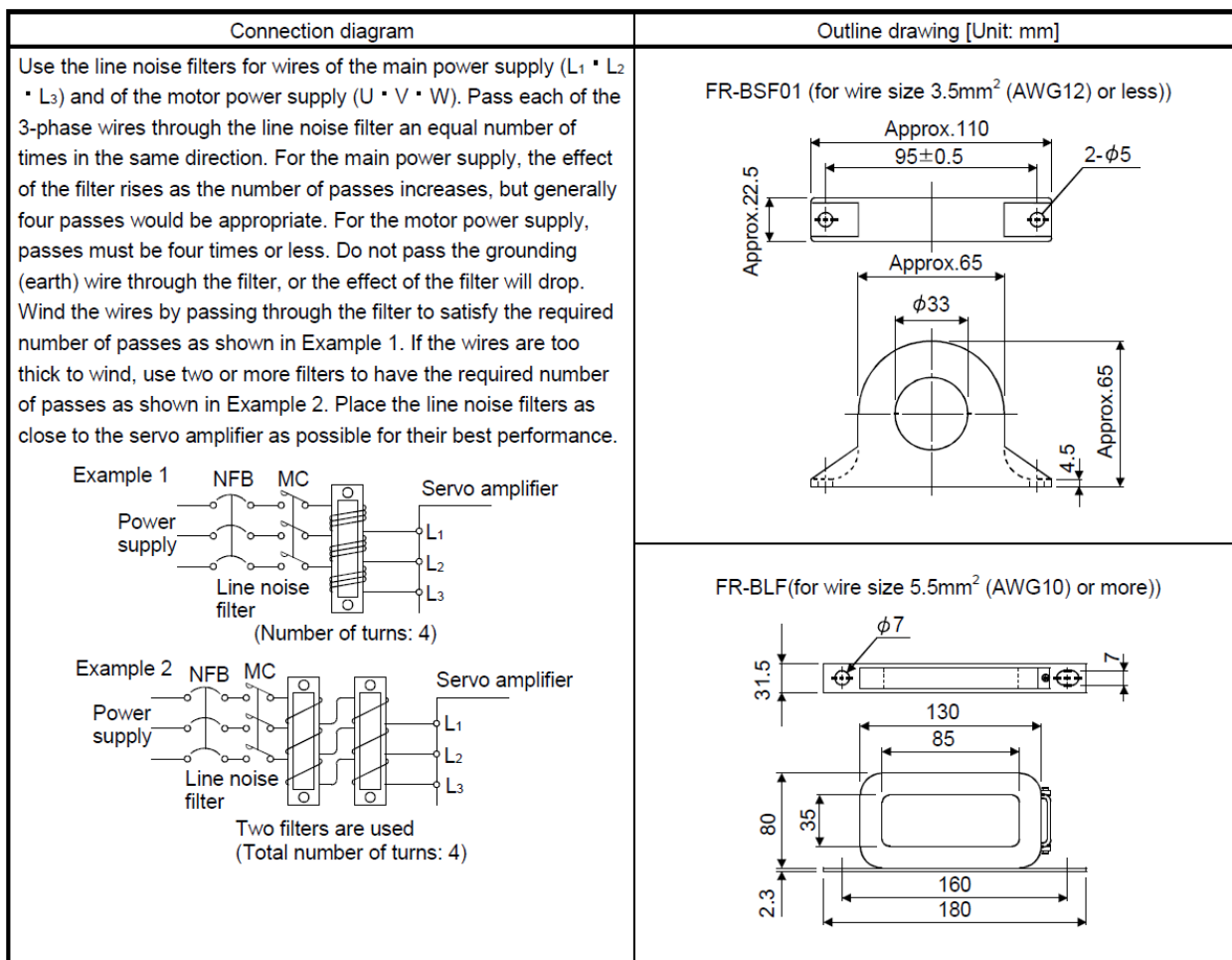

Fig.3-18 : Example of noise filter installation

### 3.8 Magnet contactor control connector output (AXMC) for addition axes

When an additional axis is used, the servo ON/OFF status of the additional axis can be synchronized with the servo ON/OFF status of the robot itself by using the output contact (AXMC) provided on the rear or inside of the controller and configuring a circuit so that the power to the servo amplifier for the additional axis can be turned off when this output is open.

An example circuit is shown in Page 141, "(1) Example circuit". An image of how to connect the connector is shown in Page 142, "(2) Image of how to connect the controller connector".

When you are using an additional axis, please perform appropriate circuit connections by referring to these drawings.

Refer to Page 137, "3.7 Additional Axis Function" and the separate "Additional axis interface Instruction Manual" for details on the additional axis function.

Note1) you use the addition axis function as a user mechanism who became independent of the robot arm, please do not connect this output signal. Servo-on of the user mechanism may be unable.

#### (1) Example circuit

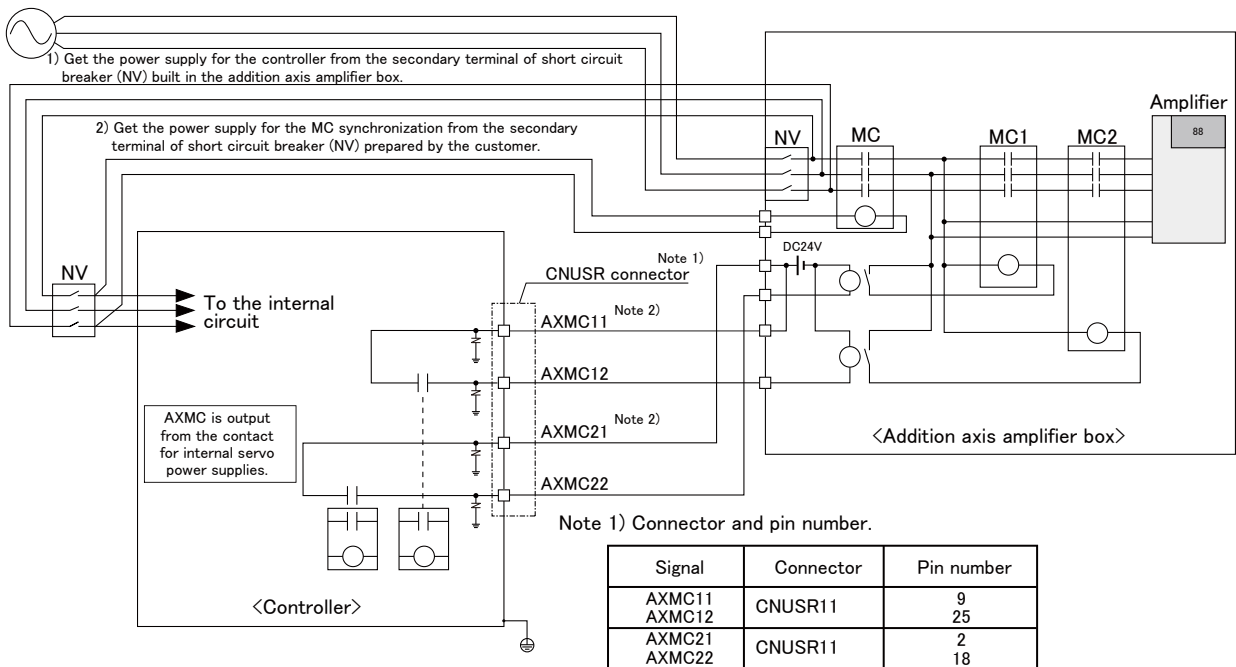

Note 2) This output is opened, if the robot turns off the servo by occurrence of alarm etc.  
<Electric specification>  
DC24V/10mA to 100mA

[Note] For the input/output cable (CNUSR connector cable) that connects customer's system and the controller, prevent ground faults from occurring at the + side of the 24V power supply prepared by customer. A ground fault may lead to a failure of the protection device in the controller.

Bending or frictional forces may be applied to the input/output cable repeatedly depending on the system configuration or layout. In this case, use a flexible cable for the input/output cable. Note that a fixed cable may be broken, resulting in a ground fault.

Fig.3-19 : Example of circuit for addition axes of Magnet contactor control output

(2) Image of how to connect the controller connector

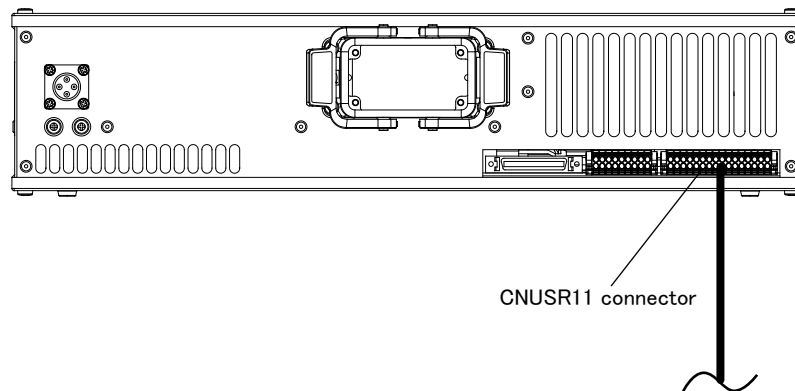

\* Refer to [Page 133 "Fig. 3-12: Wiring method to the user wiring connector"](#) for more details about how to wire a connector.

Fig.3-20 : AXMC terminal connector

### 3.9 Options

■ What are options?

There are a variety of options for the robot designed to make the setting up process easier for user needs. User installation is required for the options.



## 3.9.1 CR800-D/R/Q controller common

## (1) Teaching pendant (T/B)

- Order type: ● R32TB :Cable length 7m  
 ● R32TB-15 :Cable length 15m

## ■ Outline



This is used to create, edit and control the program, teach the operation position and for jog feed, etc. For safety proposes, a 3-position enable switch is mounted.\*1)

For multiple robots, you can operate them with just one teaching pendant by repeating the removal of it from another robot and the connection of it to the target robot.

## ■ Configuration

Table 3-14 : Configuration device

Part name	Type	Qty.	Mass (kg) <sup>Note1)</sup>	Remarks
Teaching pendant	R32TB	Either one pc.	1.7	Cable length is 7m.
	R32TB-15		2.8	Cable length is 15m.

Note1) Mass indicates one set.

## ■ Specifications

Table 3-15 : Specifications

Items	Specifications	Remarks
Outline dimensions	195(W) x 292(H) x 106(D) (refer to outline drawing)	
Body color	Dark gray	
Mass	Approx. 0.9kg (body only, excluding cables)	
Connection method	Connects with controller via connector.	
Interface	RS-422	
Display method	LCD method: 24 characters x 8 lines, LCD illumination: with backlight	At 8x8 font
Operation section	36 keys	

## \*1) &lt;3-position enable switch&gt;

In ISO/10218 (1992) and JIS-B8433 (1993), this is defined as an "enable device". These standards specify that the robot operation using the teaching pendant is enabled only when the "enable device" is at a specified position. With the Mitsubishi Electric industrial robot, the above "enable device" is configured of an "Enable/Disable switch" and "Enable switch".

The 3-position enable switch has three statuses. The following modes are entered according to the switch state.

- a) "Not pressed" .....The robot does not operate. \*)
- b) "Pressed lightly" .....The robot can be operated and teaching is possible.
- c) "Pressed with force" .....The robot does not operate. \*)

\*) Operations, such as program editing and status display, other than robot operation are possible.

Safety is secured as the servo power is turned OFF simultaneously with the input of the emergency stop.

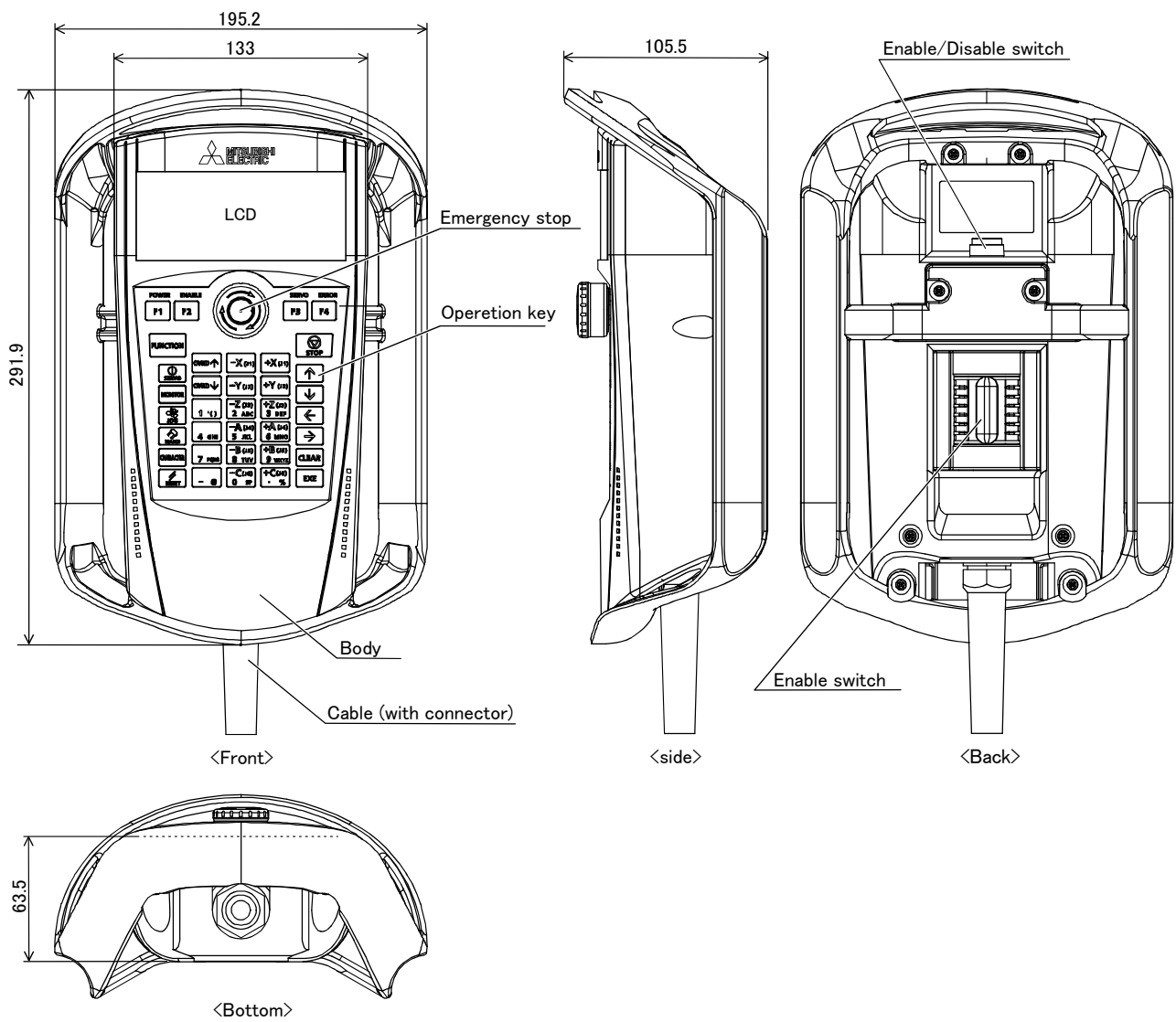

Fig.3-21 : Outside dimensions of teaching pendant

■ Installation method

The teaching pendant is connected to the TB connector on the front of the controller.

### ■ Key layout and main functions



Fig.3-22 : Teaching pendant key layout and main functions

(2) High efficient teaching pendant (T/B)

- Order type: ● R56TB :Cable length 7m
- R56TB-15 :Cable length 15m

■ Outline



This is used to create, edit and control the program, to teach the operation position, or to perform jog feed, etc. This highly efficient teaching pendant has a touchscreen graphical user interface (GUI) which allows easy operation. In addition, the 3-position enable switch \*1) is provided for the safety use.

For multiple robots, you can operate them with just one teaching pendant by repeating the removal of it from another robot and the connection of it to the target robot.

■ Configuration

Table 3-16 : Configuration device

Part name	Type	Qty.	Mass (kg) Note1)	Remarks
High efficient teaching pendant	R56TB	Either one pc.	2.1	Cable length is 7m.
	R56TB-15		3.2	Cable length is 15m.

Note1) Mass indicates one set.

■ Specifications

Table 3-17 : Specifications

Items	Specifications	Remarks
Outline dimensions	252(W) x 240(H) x 114(D) (refer to outline drawing)	
Body color	Dark gray	
Mass	Approx. 1.25kg (body only, excluding cables)	
Connection method	Connects with controller via connector.	
Interface	RS-422, Ethernet (10BASE-T)	For connection with robot controller
	USB host	Note1)
Display	6.5" TFT (640 x 480) color touchscreen, with backlight	

Note1) The operation of the following USB memory sticks has been confirmed.

- a) Kingston Data Traveler .....Manufacture: Kingston, Type: USB 2.0 memory stick, Memory sizes: 128 MB - 1GB
- b) Transcend Jet Flash .....Manufacture: Transcend, Type: USB 2.0 memory stick, Memory sizes: 128 MB - 1GB

Notice) The operation of those other than the above is not guaranteed.

■ Installation method

The teaching pendant is connected to the TB connector on the front of the controller.

\*1) <3-position enable switch>

In ISO/10218 (1992) and JIS-B8433 (1993), this is defined as an "enable device". These standards specify that the robot operation using the teaching pendant is enabled only when the "enable device" is at a specified position. With the Mitsubishi Electric industrial robot, the above "enable device" is configured of an "Enable/Disable switch" and "Enable switch".

The 3-position enable switch has three statuses. The following modes are entered according to the switch state.

- a) "Not pressed" ..... The robot does not operate. \*)
- b) "Pressed lightly" ..... The robot can be operated and teaching is possible.
- c) "Pressed with force" ..... The robot does not operate. \*)

\*) Operations, such as program editing and status display, other than robot operation are possible.

Safety is secured as the servo power is turned OFF simultaneously with the input of the emergency stop.

### ■ Outside dimensions and main functions

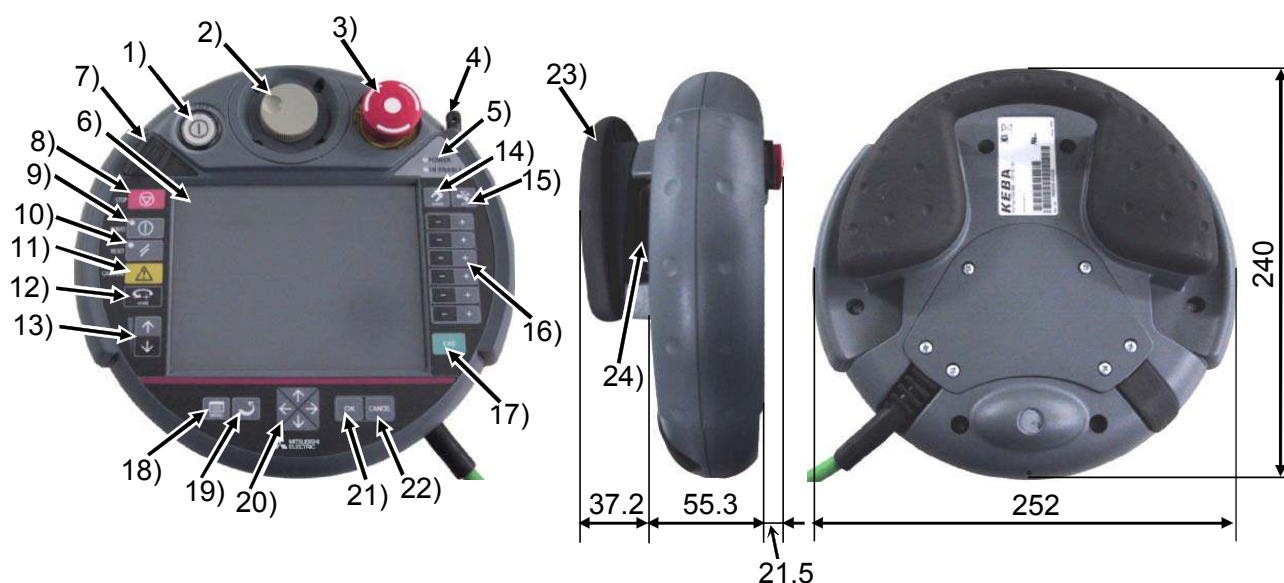

- 1) TEACH button ..... This changeover switch is used to enable or disable the T/B key operations. The lamp (white) lights up during enabling state.
- 2) Wheel ..... Move the cursor to select the menu and so on.
- 3) Emergency stop button ..... This stops the robot in an emergency state. The servo turns OFF. Turn to the right to cancel.
- 4) Touch stylus (Integrated in housing)  
The pen which operates the touch panel.
- 5) Power supply LED, T/B enable LED  
POWER LED lights up during supplying the power supply. TB ENABLE LED lights up during enabling state.
- 6) Touch panel ..... Tap to operate with the stylus pen and the screen is displayed.
- 7) USB connector ..... Plug-in the USB memory stick.
- 8) STOP button ..... This stops the robot immediately. The servo does not turn OFF.
- 9) SERVO button ..... This turns ON the servo power simultaneously with the enable switch. The LED (green) lights during servo ON.
- 10) RESET button ..... This key resets an error state that has occurred.
- 11) CAUTION button ..... If this button is pushed in jog operation, the limit switch can be canceled. Moreover, push this button, when releasing the brake.
- 12) HOME button ..... Not use.
- 13) OVRD button ..... This scrolls override up or down.
- 14) HAND button ..... Display the screen of hand operation.
- 15) JOG button ..... Display the screen of jog operation.
- 16) +/- button ..... This button operates corresponding to the selected operation.
- 17) EXE button ..... Move the robot, such as hand alignment.
- 18) MENU button ..... Display the menu screen.
- 19) RETURN button ..... Close each operation screen.
- 20) Arrow button ..... Move the cursor
- 21) OK button ..... Fix each screen operation.
- 22) CANCEL button ..... Cancel each screen operation.
- 23) Multi grip handle ..... Holds the T/B.
- 24) Enable switch ..... If this switch is released or pressed with force while the T/B is enabled, the servo power supply turns OFF. To move the robot in jog operation or the like, press the switch lightly and hold it. The enable switch is mounted on each of the multi grip handle.

Fig.3-23 : Teaching pendant outside dimensions and main functions

(3) Function extension card

- Order type: 2F-DQ510 .....MELFA Smart Plus card pack (A-type)
- 2F-DQ520 .....MELFA Smart Plus card pack (AB-type)
- 2F-DQ511 .....MELFA Smart Plus card (A-type)
- 2F-DQ521 .....MELFA Smart Plus card (B-type)

■ Outline



This card is used to enable the MELFA Smart Plus option.  
 Insert this card in the option slot on the front of the controller, and enable the MELFA Smart Plus software extension function.

■ Configuration

Table 3-18 : Configuration device

Part name		Type	Qty.	Mass (Kg)	Remarks
MELFA Smart Plus card pack	A-type	2F-DQ510	1	0.5	
	AB-type	2F-DQ520	1	0.5	Software version of controller: Ver. A3 or later
MELFA Smart Plus card	A-type	2F-DQ511	1	0.5	
	B-type	2F-DQ521	1	0.5	Software version of controller: Ver. A3 or later

## (4) Controller protection box

■ Order type: CR800-MB

■ Outline

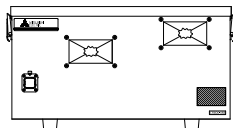

Storing the controller in this box protects the controller from dust and water. Use this option, when the controller is installed where environment is oil mist such as machine shop etc.

■ Configuration

Table 3-19 : Configuration equipment and types

Part name	Type	Qty.	Mass (Kg) <sup>Note1)</sup>	Remarks
Controller protection box	CR800-MB	1	21	
Label for serial number		1		
Transparent seal		1		
Cable tie	T50L	4		
Screw for fixing of the controller mounting plate	M4x8	4		
Instruction Manual	BFP-A3501	1	-	

Note1) Mass indicates one set.

■ Specifications

Table 3-20 : Specifications

Item	Unit	Specifications	Remarks
Outside dimension	mm	500(W) × 725(D) × 250(H)	Protrusions such as rubber legs are excluded.
Mass	kg	21	
Construction		IP54 <sup>Note1)</sup>	Self-contained floor type
Grounding	Ω	100 or less (class D grounding)	
Paint color		Dark gray	Equivalent to Munsell: 3.5PB3.2/0.8, PANTONE: 432C

Note1) In the environment where oil, such as machining oil, drops on the controller protection box, provide a shield plate to protect the controller protection box from the oil droplets.

- (1) The robot must be grounded by the customer.
- (2) The customer needs to prepare the power cable for protection box fan and the grounding cable.  
(Power supply voltage for fan: 200 VAC, Screw size for power supply connection terminal block: M4)

■ Outside dimension

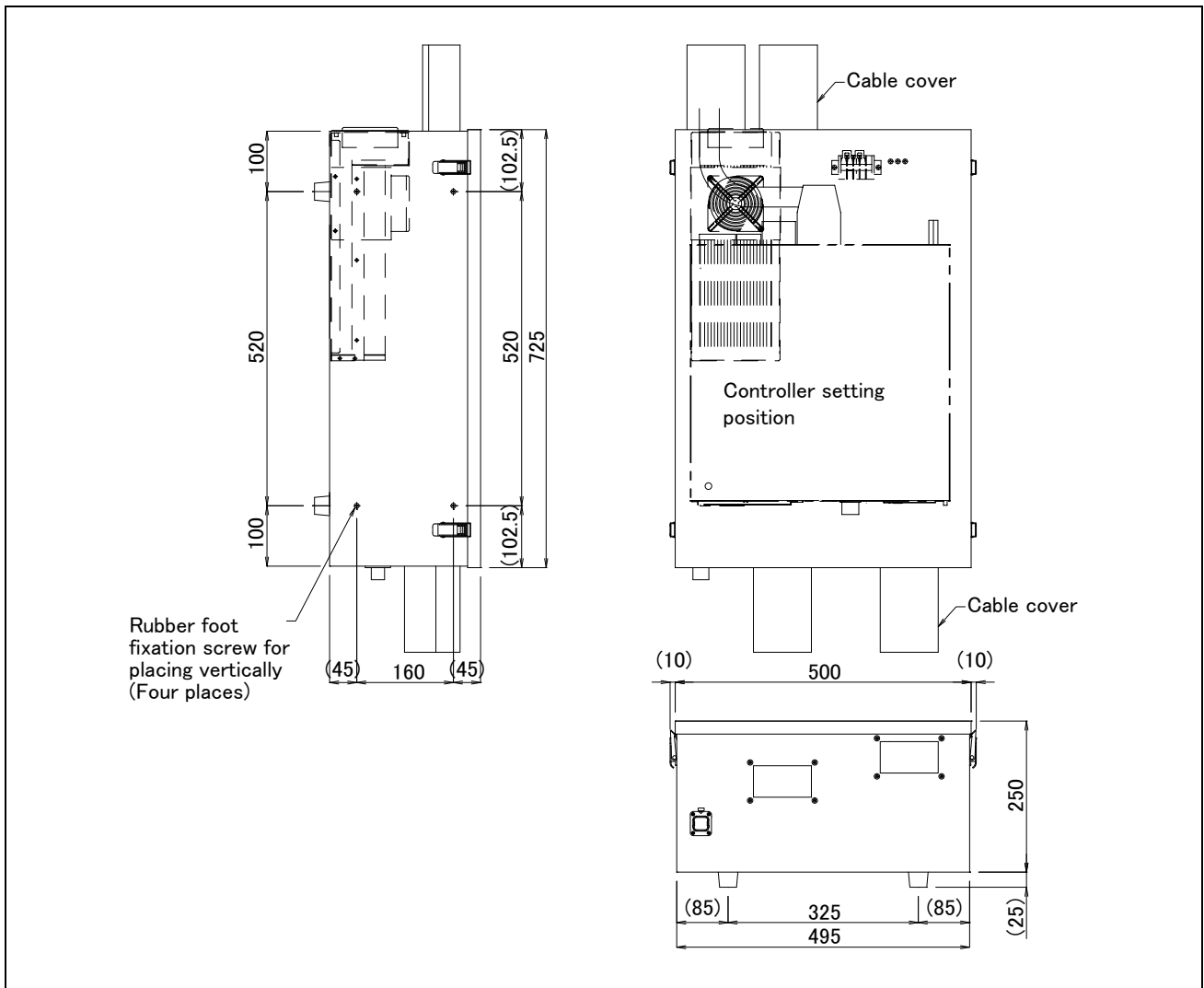

Fig.3-24 : Outside dimension



■ Names of each part

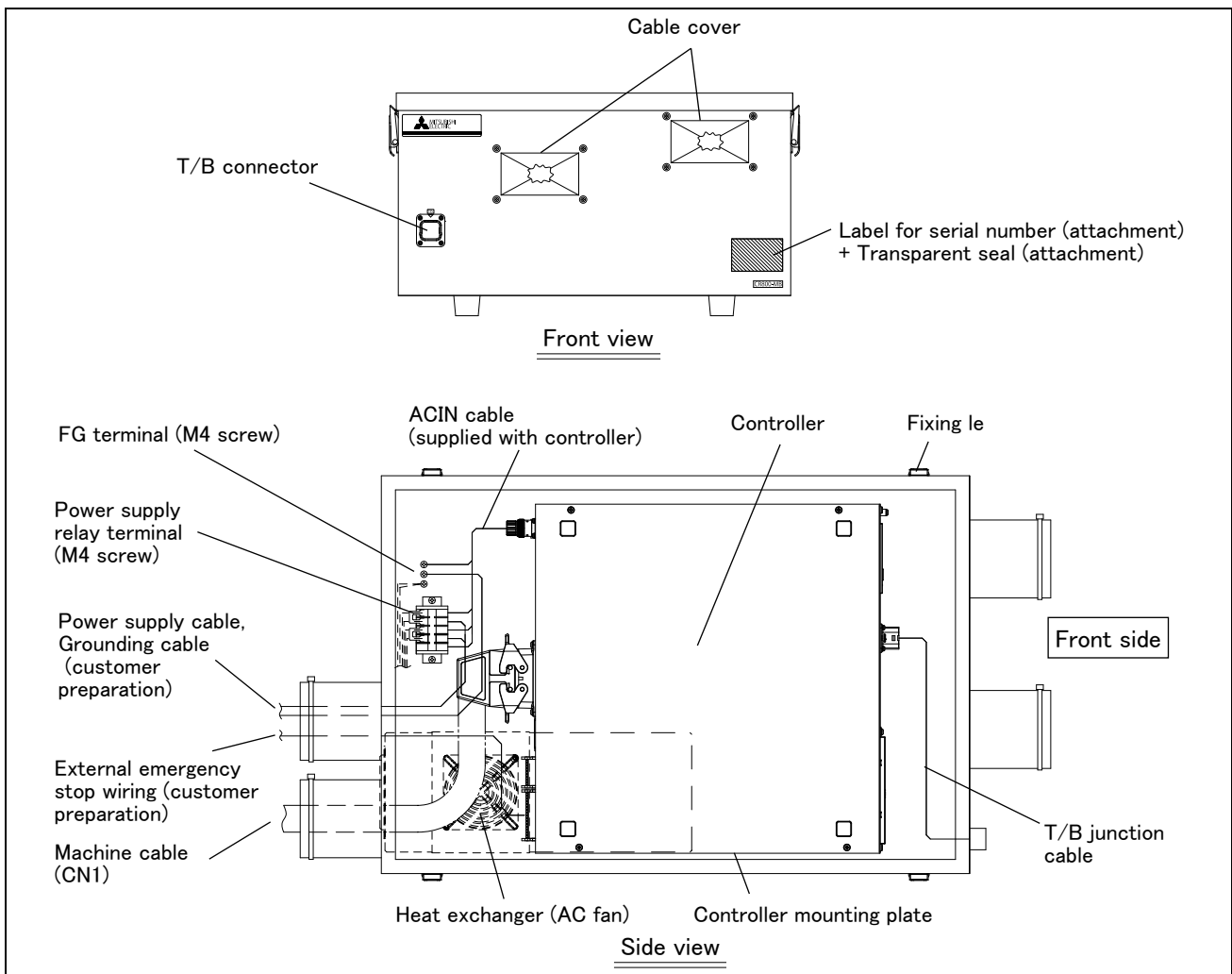

Fig.3-25 : Names of each part

■ Wiring system diagram

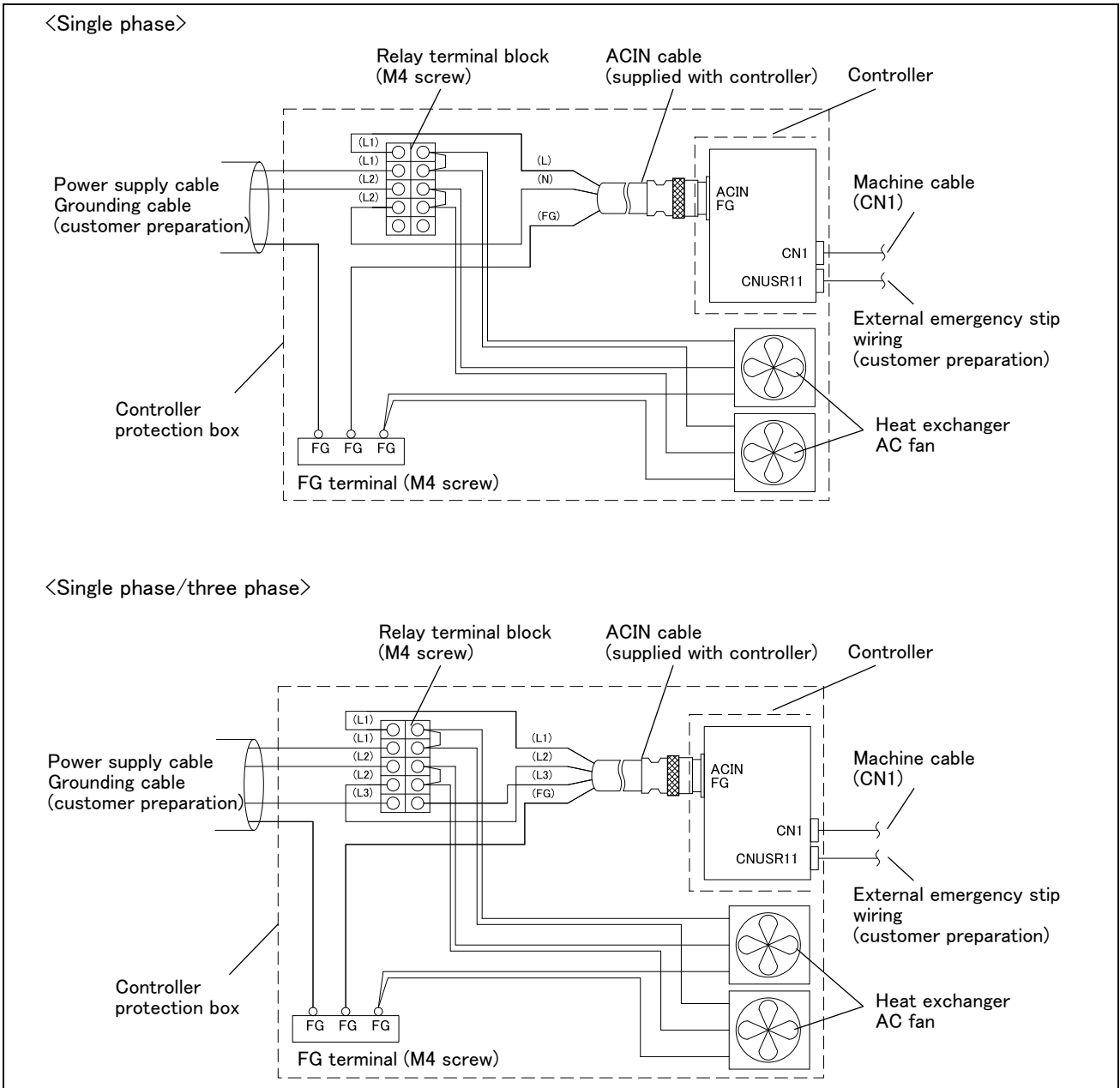

Fig.3-26 : Wiring system diagram

[ Note] The figure above is a diagrammatic illustration. The layout inside the controller protection box shown in the figure differs from the actual layout.

## ■ Installation dimensions

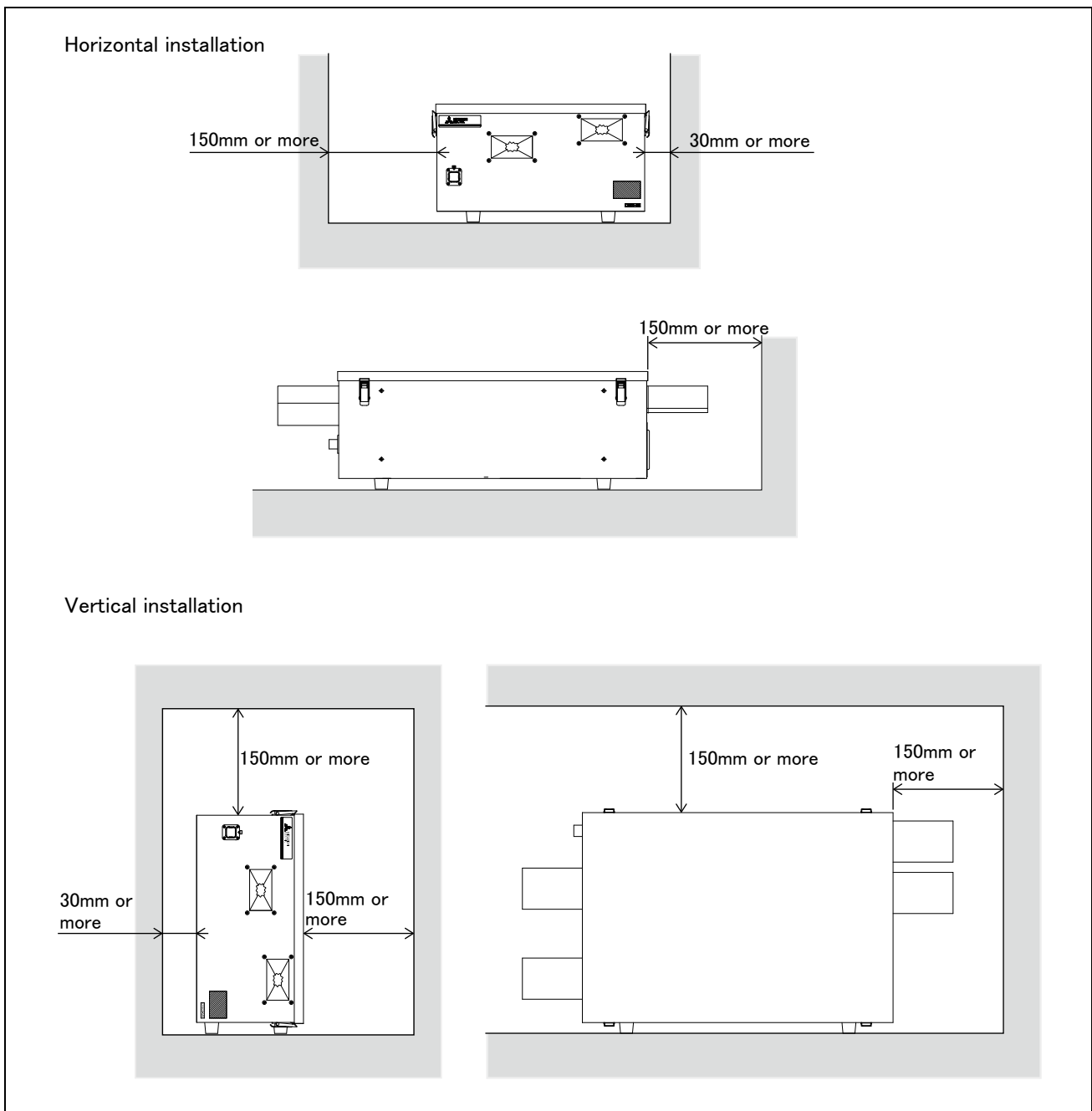

Fig.3-27 : Installation dimensions

(5) MELSOFT RT ToolBox3/MELSOFT RT ToolBox3 mini/MELSOFT RT ToolBox3 Pro

- Order type : ● MELSOFT RT ToolBox3  
\*For windows CD-ROM : 3F-14C-WINE
- MELSOFT RT ToolBox3 mini  
\*For windows CD-ROM : 3F-15C-WINE
- MELSOFT RT ToolBox3 Pro  
\*For windows DVD-ROM : 3F-16D-WINE

■ Outline



This is handy software that fully uses the personal computer functions. It can be used in various stages from the robot specifications study (tact study, etc.) to the design support (creation and editing of programs), start up support (execution, control and debugging of program), and maintenance (maintenance forecast).

■ Configuration

Table 3-21 : Product configuration

Part name	Type	Medium	Mass (kg) <sup>Note1)</sup>	Remarks
RT ToolBox3	3F-14C-WINE	CD-ROM	0.2	
RT ToolBox3 mini	3F-15C-WINE	CD-ROM	0.2	
RT ToolBox3 Pro	3F-16D-WINE	DVD-ROM	0.2	

Note1) Mass indicates one set.

■ Features

- (1) Simple operation with guidance method and menu method  
The Windows standard is used for windows operation, so the controller initialization and startup operations can be carried out easily by following the instructions given on the screen. Even a beginner can easily carry out the series of operations from program creation to execution.
- (2) Increased work efficiency with ample support functions  
The work efficiency is greatly improved with the multi-window method that carries out multiple steps and displays in parallel. The renumbering function, and copy, search, syntax check and step execution are especially sufficient, and are extremely useful when editing or debugging the program.  
With the simulation function support of MELSOFT RT ToolBox3, the program can be debugged and the tact checked before starting the machine at the site. This allows the on-site startup work efficiently to be greatly improved.  
MELSOFT RT ToolBox3 Pro allows a simulation of robot operation on three-dimensional CAD software Solid-Works®.
- (3) The maintenance forecast function increases the efficiency of maintenance work. Analyze the load condition while the robot is actually operating. Based on this analysis, calculate the time for maintenance, such as lubrication and belt replacement. By utilizing this information, the line stop time as well as the maintenance costs can be reduced.
- (4) The position recovery support function increases the recovery efficiency in the event of origin position displacement. This function compensates the origin settings and position data by just reproducing several previous teaching points when hand and/or arm displacement occurs, when replacing the motor and the belts, or when reloading the robot. This function can reduce the time required for recovery.

## ■ Functions

Table 3-22 : Functions

Function		Functional existence <sup>Note1)</sup>			Details
Compatible model		○	○	○	Personal computer running Windows XP, Windows Vista, Windows 7, Windows 8, Windows 8.1, or Windows 10. <sup>Note2)</sup>
Program editing functions	Editing functions	○	○	○	<ul style="list-style-type: none"> <li>• MELFA BASIC V, VI language compatible</li> <li>• Multiple editing screen simultaneously display</li> <li>• Command input, comment writing</li> <li>• Position data editing</li> <li>• File operation (writing to controller, personal computer)</li> <li>• Search and replace function (using characters, line Nos., labels)</li> <li>• Copy, cut, paste, insert (per character, line), undo (per command statement, position conversion)</li> <li>• Line No. automatic generation, renumbering</li> <li>• Batch syntax check</li> <li>• Command template</li> <li>• Position conversion batch editing</li> <li>• Position variable template</li> <li>• Print, print preview</li> </ul>
	Control functions	○	○	○	<ul style="list-style-type: none"> <li>• Program file control (list, copy, movement, delete, content comparison, name change, protect)</li> </ul>
	Debugging functions	○	○	○	<ul style="list-style-type: none"> <li>• Direct editing of program in controller</li> <li>• Confirmation of robot program operation (step execution, direct execution)</li> </ul>
Simulation function		○	○	×	<ul style="list-style-type: none"> <li>• Off-line simulation of robot program operation using CG (computer graphics)</li> <li>• Tact time calculation</li> </ul>
Monitor functions		○	○	○	<ul style="list-style-type: none"> <li>• Robot operation monitor (robot operation state, stop signal, error monitor, program monitor (execution program, variables), general-purpose input/output signals (forced output possible), dedicated input/output signals, operation confirmation (operation range, current position, hand, etc.)</li> <li>• Operation monitor (working time statistics, production information, robot version)</li> <li>• Servo monitor (load)</li> </ul>
Maintenance function		○	○	○	<ul style="list-style-type: none"> <li>• Parameter setting</li> <li>• Batch, divided backup</li> </ul>
Simulation function on SolidWorks.		○	×	×	<ul style="list-style-type: none"> <li>• Off-line simulation of robot program operation using CG (computer graphics)</li> <li>• Tact time calculation</li> <li>• Complex motion path generation, etc.</li> </ul>

RT ToolBox3 mini  
(3F-15C-WINE)

RT ToolBox3  
(3F-14C-WINE)

RT ToolBox3 Pro  
(3F-16D-WINE)

Note1) The functions included with the MELSOFT RT ToolBox3, MELSOFT RT ToolBox3 mini, and the MELSOFT RT ToolBox3 Pro are shown below. ○ : Function provided × : Function not provided

Note2) Recommend corresponding to CE Marking, an FCC standard, and a VCCI standard.

(6) Instruction Manual (bookbinding)

■ Order type: ● 5F-GA01-PE01.....RV-FR series

■ Outline



This is a printed version of the CD-ROM (instruction manual) supplied with this product.

■ Configuration

Table 3-23 : Product configuration

Name	Type	Mass (Kg) <sup>Note1)</sup>	Specifications
Instruction Manual	5F-GA01-PE01	3.0	The instructions manual set of RV-FR series.
Safety Manual	BFP-A3541	-	Items relating to safety in handling the robot
Standard Specifications	BFP-A3470	-	Specification of the robot arm and controller
Robot Arm Setup & Maintenance	BFP-A3474	-	Installation method of the robot arm, jog operation, and maintenance and inspection procedures
Controller Setup, Basic Operation and Maintenance	BFP-A3476	-	Installation method of the controller, basic operation, and maintenance and inspection procedures
Detailed Explanation of Functions and Operations	BFP-A3478	-	Functions of the controller and T/B, operation method, and explanation of MELFA-BASIC VI.
Troubleshooting	BFP-A3480	-	Causes of errors occurred and their countermeasures
Additional axis function	BFP-A3504	-	Function of the additional axis, operation method.
Tracking Function	BFP-A3520	-	Function of the tracking, operation method.
GOT Direct Connection Extended Function	BFP-A3546	-	Explains of data configuration of shared memory, monitoring, and operating procedures, between the GOT and controller.
iQ Platform Supporting Extended Function Instruction Manual	BFP-A3528	-	Explains of data configuration of shared memory, monitoring, and operating procedures, between the PLC and robot controller.
Ethernet Function	BFP-A3379	-	Ethernet communication method between personal computer and robot controller.

Note1) Mass indicates one set.

## 3.9.2 CR800-D controller

## (1) Parallel I/O interface

■ Order type : ● 2D-TZ368 (Sink type)/2D-TZ378 (Source type)

■ Outline



This is used to expand the external inputs and outputs.

• The connecting cable with external equipment is not attached. Since we are preparing the external input-and-output cable (2D-CBL05 or 2D-CBL15) as the option, please use.

Notes) Although the combined use with the parallel input-and-output unit (2A-RZ361/2A-RZ371) of another option is also possible, please use the setup of the station number by the different number separately. The station number is automatically determined by the position of the option slot which installed this interface. (station number 0 to 1)

■ Configuration

Table 3-24 : Configuration device

Part name	Type	Qty.	Mass (kg) <sup>Note1)</sup>	Remarks
Parallel I/O interface	2D-TZ368	Either one pc.	0.4	Input/output 32 points/32 points 2D-TZ368 is sink type. 2D-TZ378 is source type.
	2D-TZ378			

Note1) Mass indicates one set.

■ Specifications

Table 3-25 : Electrical specifications of input circuits

Item	Specification		Internal circuit
Type	DC input		<p>&lt;Sink type&gt;</p> <p>&lt;Source type&gt;</p>
Number of input points	32		
Insulation method	Photo coupler insulation		
Rated input voltage	DC12V	DC24V	
Rated input current	Approx. 3mA	Approx.9mA	
Working voltage range	DC10.2 ~ 26.4V (Ripple factor should be less than 5%)		
ON voltage/ON current	DC8V or more/2mA or more		
OFF voltage/ OFF current	DC4V or less/1mA or less		
Input resistance	Approx. 2.7kΩ		
Response time	OFF-ON	10ms or less(DC24V)	
	ON-OFF	10ms or less(DC24V)	
Common method	32 points per common		
External cable connection method	Connector		

Table 3-26 : Electrical specifications for the output circuits

Item		Specification	Internal circuit
Type		Transistor output	<div style="display: flex; flex-direction: column; align-items: center;"> <div style="text-align: center;"> <p>&lt;Sink type&gt;</p> </div> <div style="text-align: center; margin-top: 20px;"> <p>&lt;Source type&gt;</p> </div> </div>
No. of output points		32	
Insulation method		Photo-coupler insulation	
Rated load voltage		DC12V/DC24V	
Rated load voltage range		DC10.2 ~ 30V (peak voltage DC30V)	
Max. load current		0.1A/point (100%)	
Leakage current at OFF		Within 0.1mA	
Max. voltage drop at ON		DC0.9V(TYP.) <sup>Note1)</sup>	
Response time	OFF-ON	10ms or less(Resistance load) (hardware response time)	
	ON-OFF	10ms or less(Resistance load) (hardware response time)	
Fuse rating		Fuse 1.6A(one per common) Replacement possible (max. 3)	
Common method		16 points per common (common terminal: 2points)	
External wire connection method		Connector	
External power supply	Voltage	DC12/24V(DC10.2 ~ 30V)	
	Current	60mA(TYP.DC24V per common)(base drive current)	

Note1) The maximum voltage drop value at signal ON.  
Refer to it for the equipment connected to the output circuit.

**Caution** The protection fuse of the output circuit prevents the failure at the time of the load short circuit and incorrect connection. The load connected of the customer should be careful not to exceed maximum rating current. The internal transistor may be damaged if maximum rating current is exceeded.

■ Installation method

The expansion parallel input/output interface is installed in the controller. Refer to separate "Instruction Manual/ Controller setup, basic operation, and maintenance" for details on the installing method.  
If it installs in the option SLOT of the controller, the station number will be assigned automatically.

- SLOT1: station number 0 (0 to 31)
- SLOT2: station number 1 (32 to 63)

**Caution** If it uses together with parallel input-and-output unit 2A-RZ361/2A-RZ371, please do not overlap with the station number of the parallel input-and-output interface.

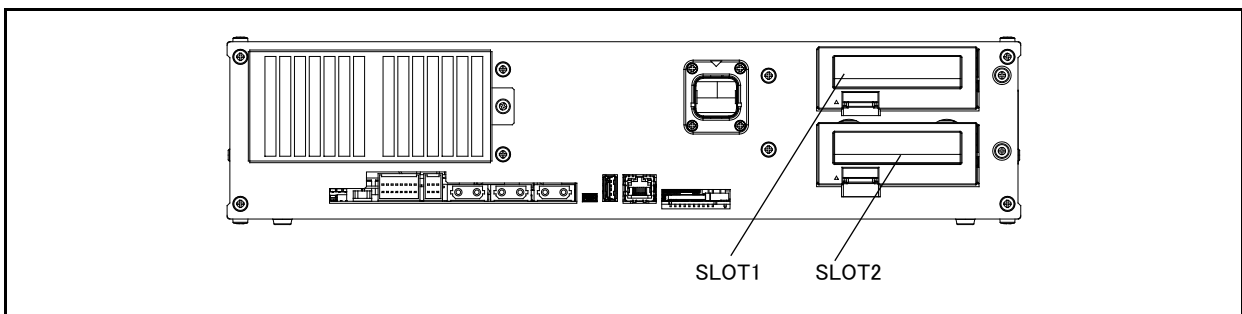

Fig.3-28 : Parallel I/O interface installation position



### ■ Pin layout of connector

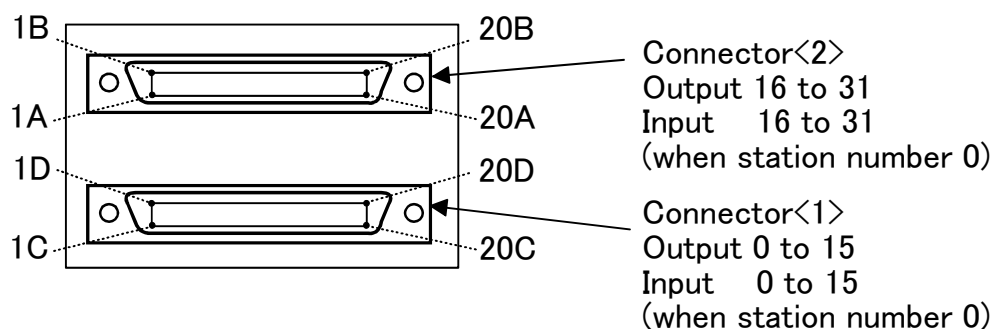

Fig.3-29 : Pin layout of connector

### ■ Connector pin No. and signal assignment

The station number is fixed by the slot to install and the allocation range of the general-purpose input-and-output signal is fixed.

Table 3-27 : The slot number and the station number

Slot number	Station number	Range of the general-purpose input-and-output signal	
		Connector <1>	Connector <2>
SLOT1	0	Input : 0 to 15 Output : 0 to 15	Input : 16 to 31 Output : 16 to 31
SLOT2	1	Input : 32 to 47 Output : 32 to 47	Input : 48 to 63 Output : 48 to 63

The connector pin number of the parallel input-and-output interface installed in SLOT1 and signal number allocation are shown in [Table 3-28](#) and [Table 3-29](#). If it installs in other slots, please interpret and utilize.

Table 3-28 : Connector<1> pin assignment list and external I/O cable (2D-CBL\*\*) color(SLOT1)

Pin No.	Line color	Function name		Pin No.	Line color	Function name	
		General-purpose	Dedicated/power supply, common			General-purpose	Dedicated/power supply, common
1C	Orange/Red a	General-purpose input 15	24G/12G: For pins 5D-20D	1D	Orange/Black a	General-purpose output 15	+24V/+12V(COM): For pins 5D-20D
2C	Gray/Red a		COM : For pins 5C-20C <sup>Note1)</sup>	2D	Gray/Black a		Reserved
3C	White/Red a		Reserved	3D	White/Black a		Reserved
4C	Yellow/Red a		Reserved	4D	Yellow/Black a		Reserved
5C	Pink/Red a			5D	Pink/Black a		
6C	Orange/Red b	General-purpose input 14		6D	Orange/Black b	General-purpose output 14	
7C	Gray/Red b	General-purpose input 13		7D	Gray/Black b	General-purpose output 13	
8C	White/Red b	General-purpose input 12		8D	White/Black b	General-purpose output 12	
9C	Yellow/Red b	General-purpose input 11		9D	Yellow/Black b	General-purpose output 11	
10C	Pink/Red b	General-purpose input 10		10D	Pink/Black b	General-purpose output 10	
11C	Orange/Red c	General-purpose input 9	Operation rights input signal <sup>Note2)</sup>	11D	Orange/Black c	General-purpose output 9	
12C	Gray/Red c	General-purpose input 8		12D	Gray/Black c	General-purpose output 8	
13C	White/Red c	General-purpose input 7		13D	White/Black c	General-purpose output 7	
14C	Yellow/Red c	General-purpose input 6		14D	Yellow/Black c	General-purpose output 6	
15C	Pink/Red c	General-purpose input 5		15D	Pink/Black c	General-purpose output 5	
16C	Orange/Red d	General-purpose input 4	Servo ON input signal <sup>Note2)</sup>	16D	Orange/Black d	General-purpose output 4	Operation rights output signal <sup>Note2)</sup> Error occurring output signal <sup>Note2)</sup> In servo ON output signal <sup>Note2)</sup> Operating output <sup>Note2)</sup>
17C	Gray/Red d	General-purpose input 3	Start input <sup>Note2)</sup>	17D	Gray/Black d	General-purpose output 3	
18C	White/Red d	General-purpose input 2	Error reset input signal <sup>Note2)</sup>	18D	White/Black d	General-purpose output 2	
19C	Yellow/Red d	General-purpose input 1	Servo OFF input signal <sup>Note2)</sup>	19D	Yellow/Black d	General-purpose output 1	
20C	Pink/Red d	General-purpose input 0	Stop input <sup>Note3)</sup>	20D	Pink/Black d	General-purpose output 0	

Note1) Sink type: +24V/+12V(COM), Source type: 24G/12G

Note2) The dedicated signal is assigned at shipping. It can change with the parameter.

Note3) The dedicated input signal (STOP) is assigned at shipping. The signal number is fixing.

Table 3-29 : Connector<2> pin assignment list and external I/O cable (2D-CBL\*\*) color(SLOT1)

Pin No.	Line color	Function name		Pin No.	Line color	Function name	
		General-purpose	Dedicated/power supply, common			General-purpose	Dedicated/power supply, common
1A	Orange/Red a	General-purpose input 31	24G/12G: For pins 5B-20B	1B	Orange/Black a	General-purpose output 31	+24V/+12V(COM): For pins 5B-20B
2A	Gray/Red a		COM : For pins 5A-20A <sup>Note1)</sup>	2B	Gray/Black a		Reserved
3A	White/Red a		Reserved	3B	White/Black a		Reserved
4A	Yellow/Red a		Reserved	4B	Yellow/Black a		Reserved
5A	Pink/Red a			5B	Pink/Black a		
6A	Orange/Red b	General-purpose input 30		6B	Orange/Black b	General-purpose output 30	
7A	Gray/Red b	General-purpose input 29		7B	Gray/Black b	General-purpose output 29	
8A	White/Red b	General-purpose input 28		8B	White/Black b	General-purpose output 28	
9A	Yellow/Red b	General-purpose input 27		9B	Yellow/Black b	General-purpose output 27	
10A	Pink/Red b	General-purpose input 26		10B	Pink/Black b	General-purpose output 26	
11A	Orange/Red c	General-purpose input 25		11B	Orange/Black c	General-purpose output 25	
12A	Gray/Red c	General-purpose input 24		12B	Gray/Black c	General-purpose output 24	
13A	White/Red c	General-purpose input 23		13B	White/Black c	General-purpose output 23	
14A	Yellow/Red c	General-purpose input 22		14B	Yellow/Black c	General-purpose output 22	
15A	Pink/Red c	General-purpose input 21		15B	Pink/Black c	General-purpose output 21	
16A	Orange/Red d	General-purpose input 20		16B	Orange/Black d	General-purpose output 20	
17A	Gray/Red d	General-purpose input 19		17B	Gray/Black d	General-purpose output 19	
18A	White/Red d	General-purpose input 18		18B	White/Black d	General-purpose output 18	
19A	Yellow/Red d	General-purpose input 17		19B	Yellow/Black d	General-purpose output 17	
20A	Pink/Red d	General-purpose input 16		20B	Pink/Black d	General-purpose output 16	

Note1) Sink type: +24V/+12V(COM), Source type: 24G/12G

<Reference> The example of connection with our PLC

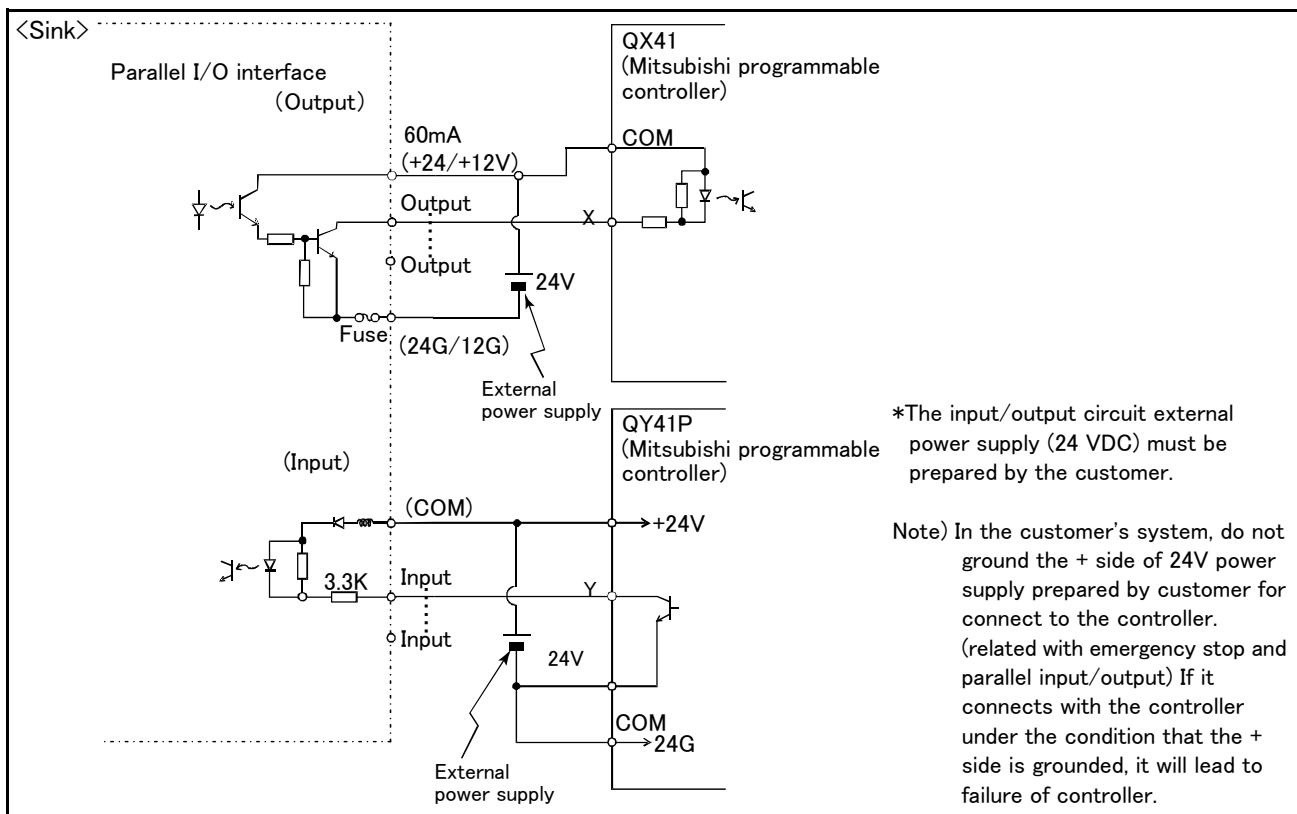

Table 3-30 : Connection with a Mitsubishi PLC (Example of sink type)

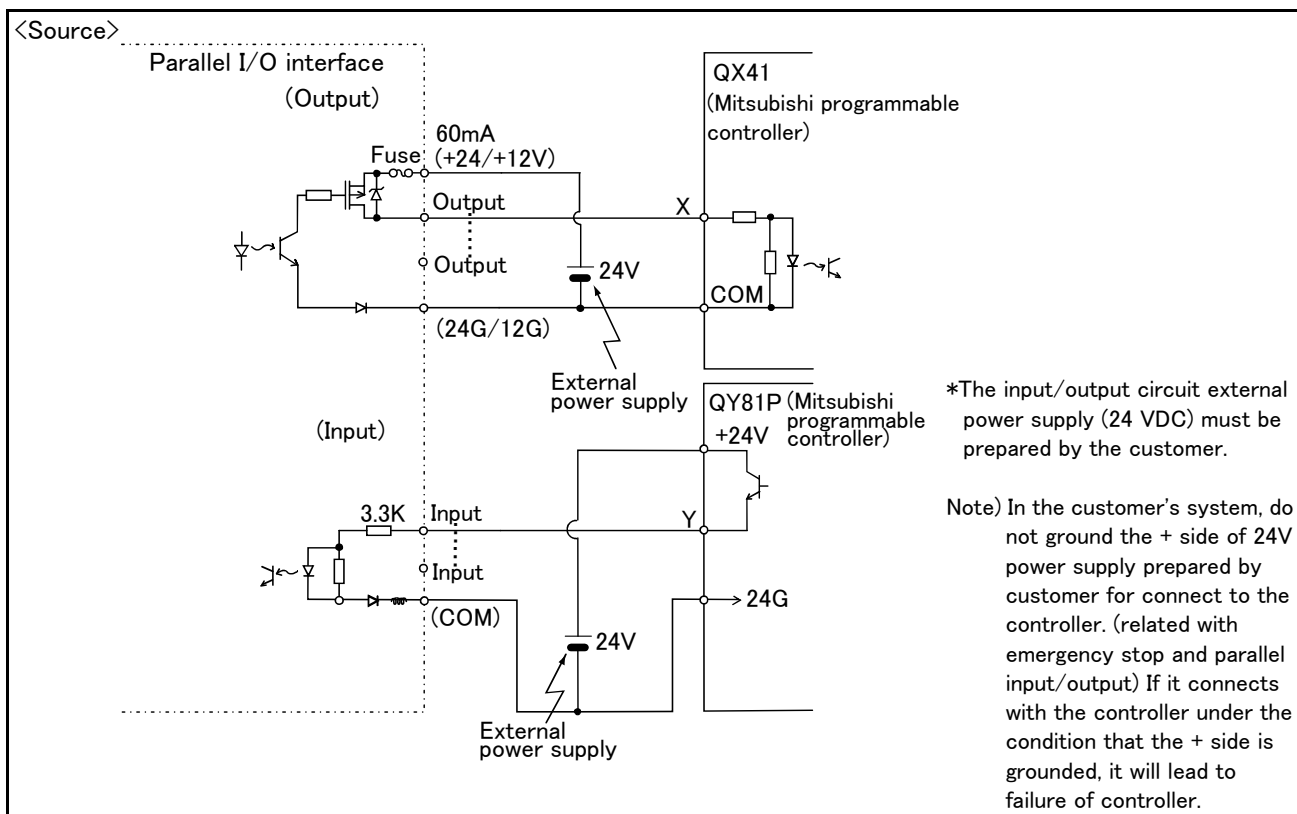

Table 3-31 : Connection with a Mitsubishi PLC (Example of source type)

(2) External I/O cable

■ Order type : ● 2D-CBL □□ (Note) The numbers in the boxes □□ refer to the length. (05: 5m, 15: 15m)

■ Outline



This is the dedicated cable used to connect an external peripheral device to the connector on the parallel I/O interface. For parallel I/O unit is another option 2A-CBL\*\*. One end matches the connector on the parallel input/output unit, and the other end is free. Connect the peripheral device's input/output signal using the free end. One cable correspond to the input 16 points and output 16 points. Two cables are needed to connection of (input 32 points and output 32 points) with built-in standard.

■ Configuration

Table 3-32 : Configuration device

Part name	Type	Qty.	Mass (kg) <sup>Note1)</sup>	Remarks
External I/O cable	2D-CBL □□	1 pc.	0.7(5m) 1.84(15m)	5m or 15m

Note1) Mass indicates one set.

■ Specifications

Table 3-33 : Specifications

Items	Specifications
Number of cables x cable size	AWG #28 x 20P (40 pairs)
Total length	5m, 15m

■ Connector pin numbers and cable colors

Table 3-34 : Connector pin numbers and cable colors

Pin no.	Cable colors	Pin no.	Cable colors	Pin no.	Cable colors	Pin no.	Cable colors
1A/C	Orange/Red a	11A/C	Orange/Red c	1B/D	Orange/Black a	11B/D	Orange/Black c
2A/C	Gray/Red a	12A/C	Gray/Red c	2B/D	Gray/Black a	12B/D	Gray/Black c
3A/C	White/Red a	13A/C	White/Red c	3B/D	White/Black a	13B/D	White/Black c
4A/C	Yellow/Red a	14A/C	Yellow/Red c	4B/D	Yellow/Black a	14B/D	Yellow/Black c
5A/C	Pink/Red a	15A/C	Pink/Red c	5B/D	Pink/Black a	15B/D	Pink/Black c
6A/C	Orange/Red b	16A/C	Orange/Red d	6B/D	Orange/Black b	16B/D	Orange/Black d
7A/C	Gray/Red b	17A/C	Gray/Red d	7B/D	Gray/Black b	17B/D	Gray/Black d
8A/C	White/Red b	18A/C	White/Red d	8B/D	White/Black b	18B/D	White/Black d
9A/C	Yellow/Red b	19A/C	Yellow/Red d	9B/D	Yellow/Black b	19B/D	Yellow/Black d
10A/C	Pink/Red b	20A/C	Pink/Red d	10B/D	Pink/Black b	20B/D	Pink/Black d

Notes) Pin number of connector<1> are 1C, 2C, ...,20C, 1D, 2D, ...,20D, connector<2> are 1A, 2A, ...,20A, 1B, 2B, ...,20B.

■ Connections and outside dimensions

The sheath of each signal cable (40 lines) is color indicated and marked with dots. Refer to the cable color specifications in "Table 3-45: Connector pin numbers and cable colors" when making the connections.

(Eg.) Pin number: color indication

1 : Orange / Red / a

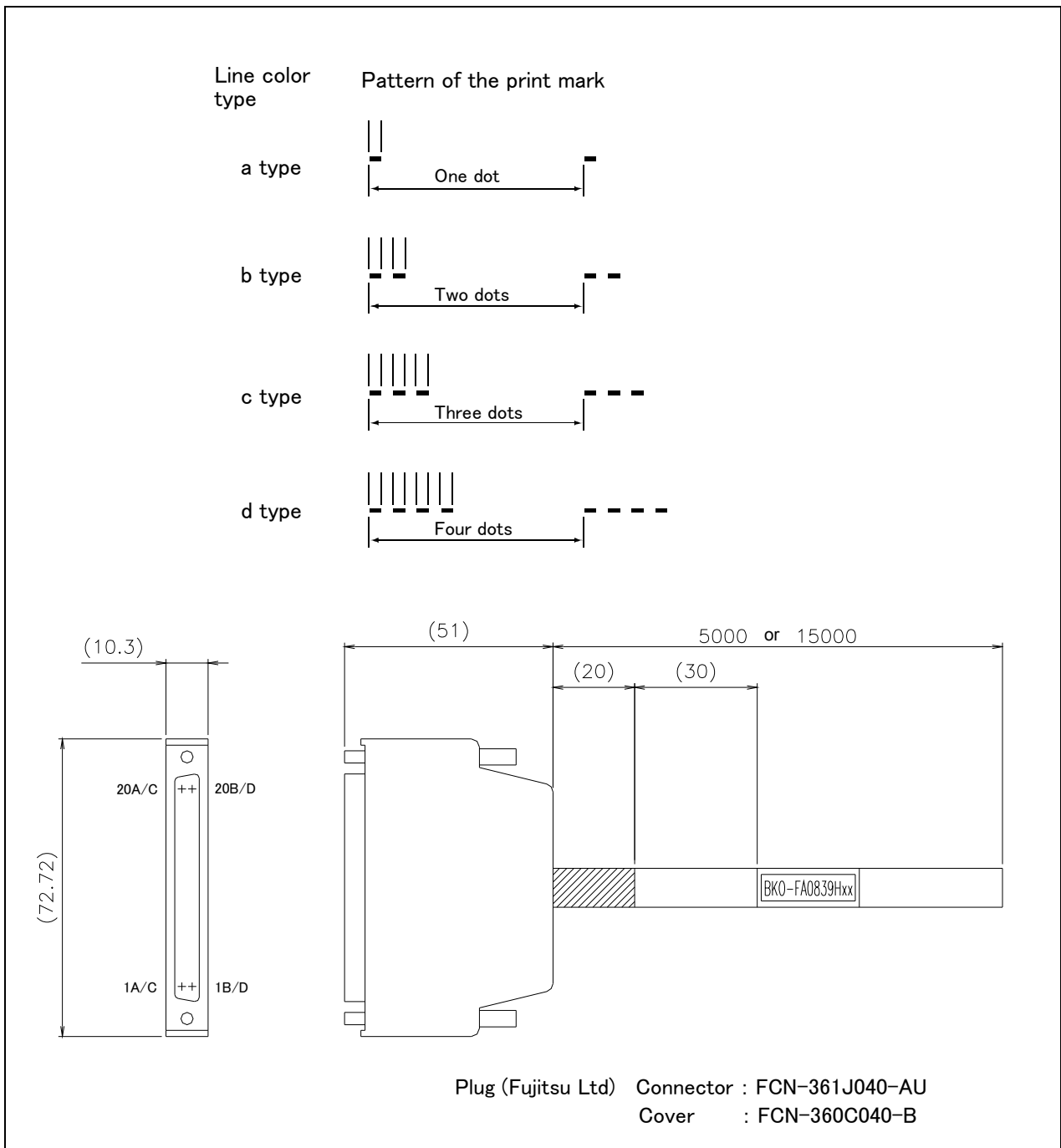
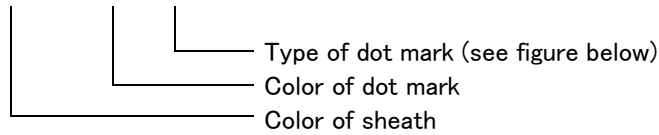

Fig.3-30 : Connections and outside dimensions

(3) Parallel I/O unit

■ Order type: 2A-RZ361(Sink type)/2A-RZ371(Source type)

■ Outline



This is used to expand the external inputs and outputs.

- The connection cable is not included. Prepare the optional external input/output cable (2A-CBL05 or 2A-CBL15).
- Use 2A-RZ361 if the external input/output signal logic is of the sink type and 2A-RZ371 for source type signal logic.

Notes) Although the combined use with the parallel I/O interface (2D-TZ368/2D-TZ378) of another option is also possible, please use the setup of the station number by the different number separately. The station number is automatically fixed by the position of the option slot which installed the parallel I/O interface in 0-1.

■ Configuration

Table 3-35 : Configuration device

Part name	Type	Qty.	Mass (kg) <sup>Note1)</sup>	Remarks
Parallel I/O unit	2A-RZ361	Either one pc.	0.7	Input/output 32 points/32 points 2A-RZ361 is the sink type. 2A-RZ371 is the source type.
	2A-RZ371			
Robot I/O link connection connector	NETcable-1	2 sets	-	Connector with pins. The cable must be prepared and wired by the customer.
Power connection connector	DCcable-2	Each 1 set	-	Connector with pins. The cable must be prepared and wired by the customer.
Terminator	R-TM	1 pc.	-	100Ω (1/4W)

Note1) Mass indicates one set.

■ Specifications

- 1) Up to eight stations can be connected to this unit (one station occupies one unit).  
The combined use with another optional parallel I/O interface (2D-TZ368/2D-TZ378) is possible, but the maximum number of stations is eight in total. In this case, set any of station numbers carefully so that they do not duplicate.
- 2) The power supply (24V) must be prepared by the customer and connected with the power connection cable (DCcable-2)  
A separate 24V power supply is required for the input/output circuit wiring.

Table 3-36 : Electrical specifications of input circuits

Item	Specification		Internal circuit
Type	DC input		<p>&lt;Sink type&gt;</p> <p>&lt;Source type&gt;</p>
Number of input points	32		
Insulation method	Photo coupler insulation		
Rated input voltage	12VDC	24VDC	
Rated input current	Approx 3mA	Approx 7mA	
Working voltage range	10.2 to 26.4VDC(Ripple factor should be less than 5%).		
ON voltage/ON current	8VDC or more/ 2mA or more		
OFF voltage/ OFF current	4VDC or less/ 1mA or less		
Input resistance	Approx. 3.3kΩ		
Response time	OFF-ON	10ms or less (24VDC)	
	ON-OFF	10ms or less (24VDC)	
Common method	8 points per common		
External cable connection method	Connector		

Table 3-37 : Electrical specifications for the output circuits

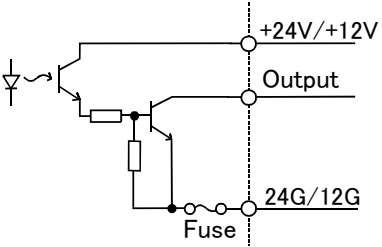
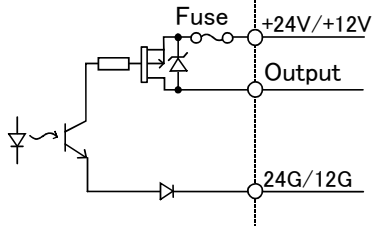
Item		Specification	Internal circuit
Type		Transistor output	<p>&lt;Sink type&gt;</p>  <p>&lt;Source type&gt;</p> 
No. of output points		32	
Insulation method		Photo-coupler insulation	
Rated load voltage		12VDC/24VDC	
Rated load voltage range		10.2 to 30VDC(peak voltage 30VDC)	
Max. load current		0.1A/point (100%)	
Leakage current at OFF		0.1mA or less	
Max. voltage drop at ON		0.9VDC(TYP.) <sup>Note1)</sup>	
Response time	OFF-ON	2ms or less (hardware response time)	
	ON-OFF	2ms or less (Resistance load) (hardware response time)	
Fuse rating		Fuse 3.2A (one per common) Replacement not possible	
Common method		8 points per common (common terminal: 4 points)	
External wire connection method		Connector	
External power supply	Voltage	12VDC/24VDC(10.2 to 30VDC)	
	Current	60mA (TYP. 24VDC per common) (base drive current)	

Note1) The maximum voltage drop value at signal ON.

Refer to it for the equipment connected to the output circuit.

### CAUTION

The output circuit protective fuses prevent failure in case of load short-circuit and improper connections. Please do not connect loads that cause the current to exceed the maximum rated current. If the maximum rated current is exceeded, the internal transistors may be damaged.

### CAUTION

Inputs the power supply for control (DCcable-2) then inputs the controller's power supply.

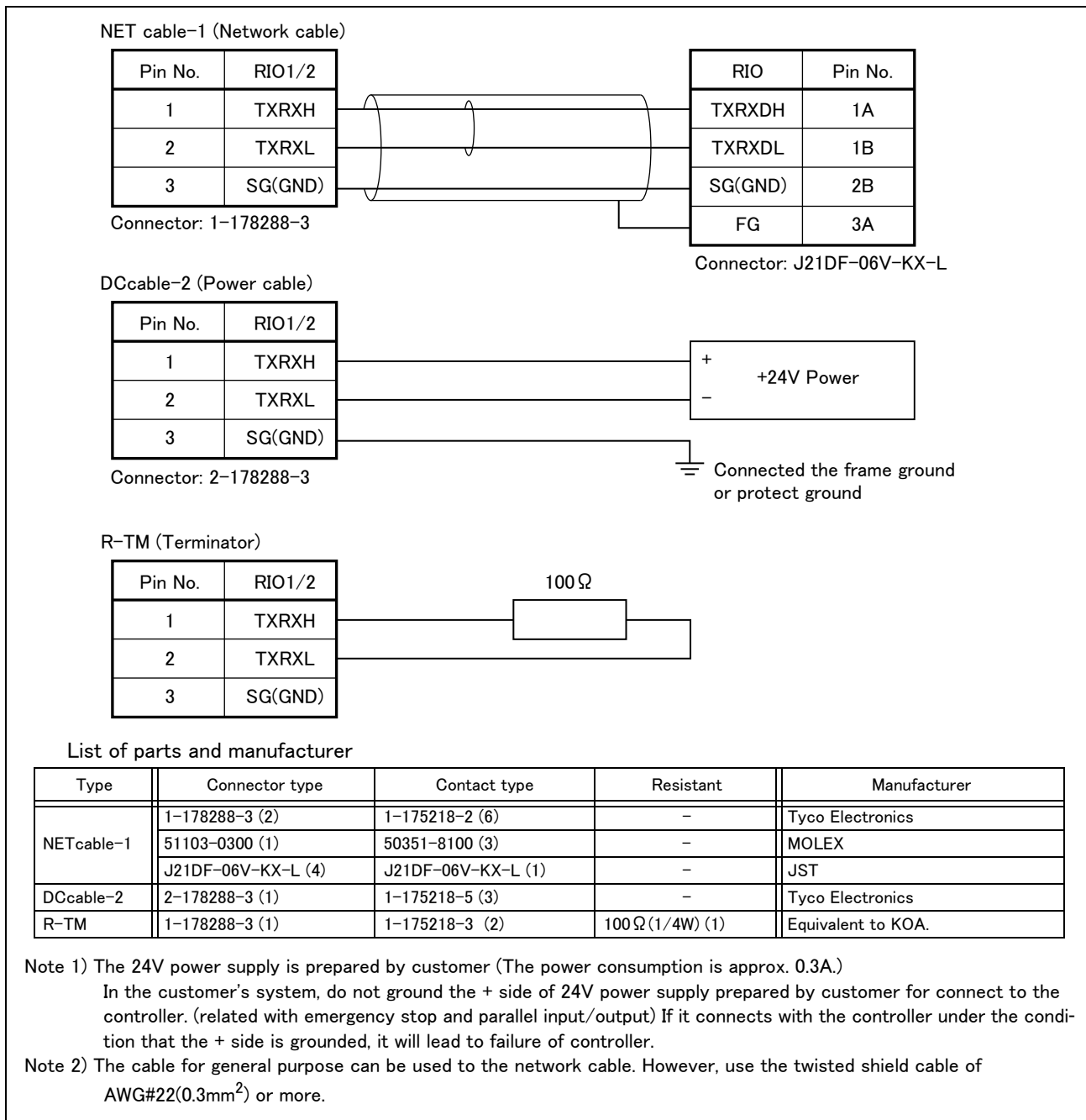

Fig.3-31 : Specifications for the connection cable



■ Installation method

The expansion parallel input/output unit is installed outside of the controller. Connect with the network connection cable (NETcable-1) from the RIO connector in the front of the controller.

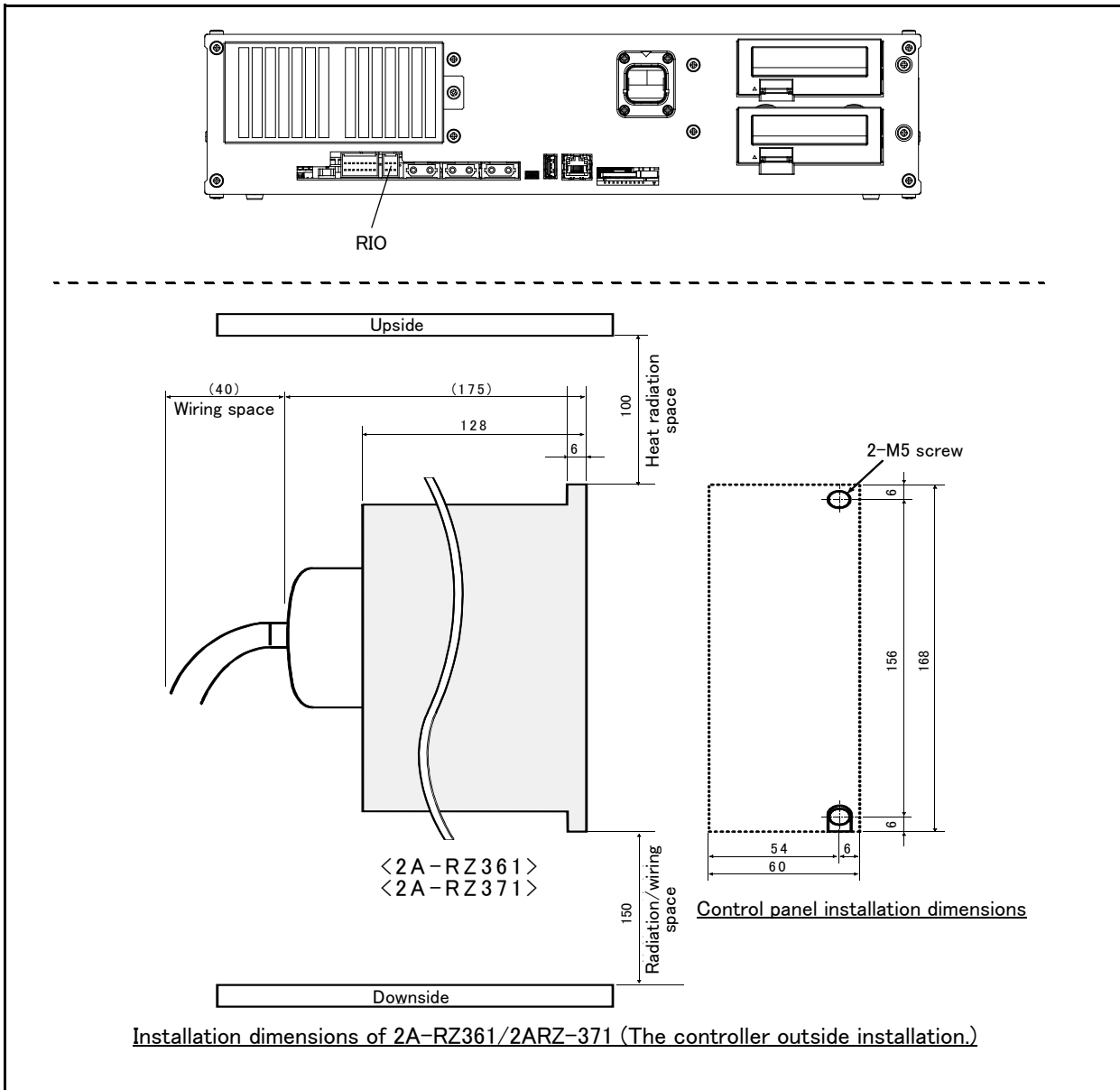

Fig.3-32 : Installing the parallel I/O unit

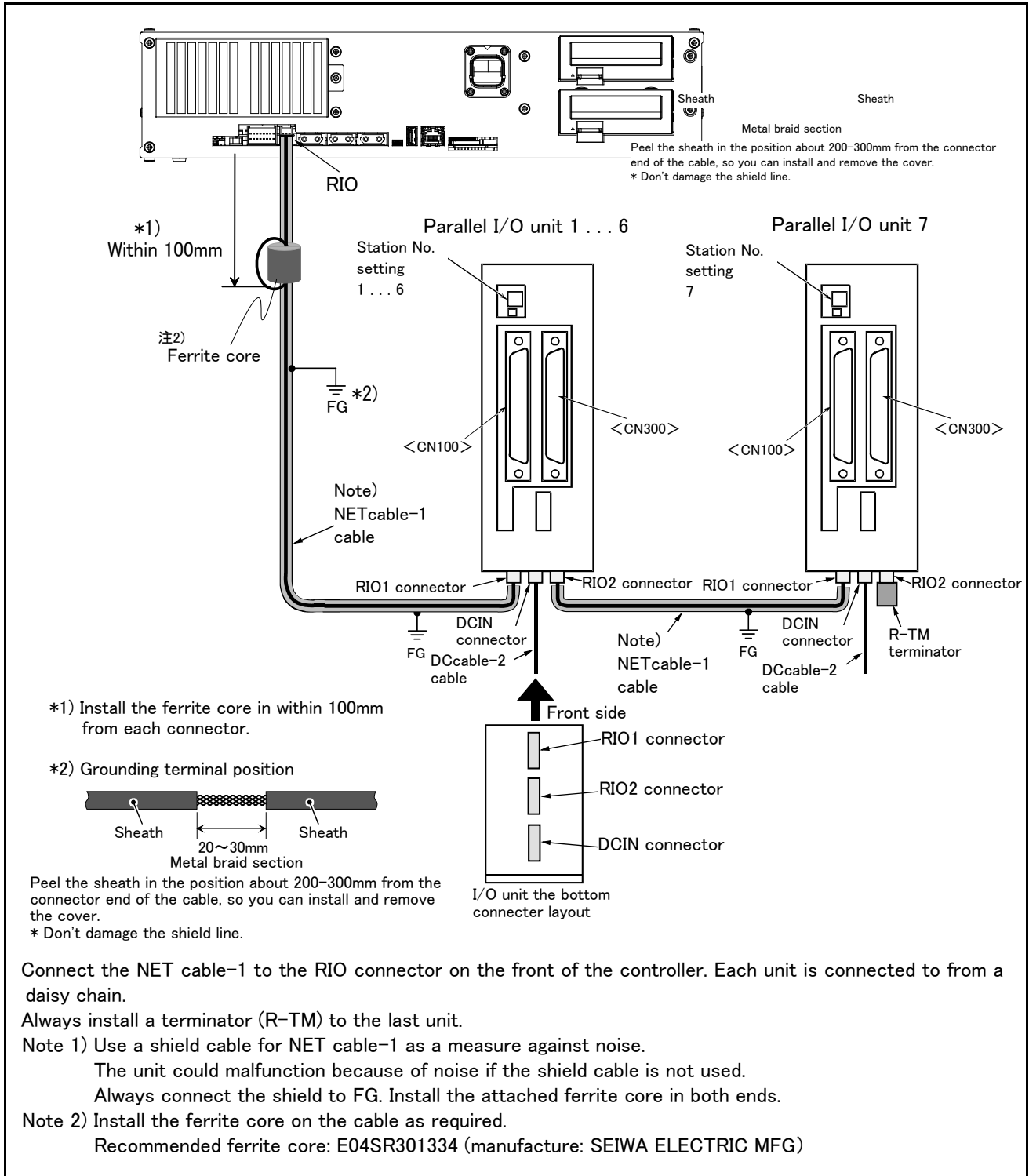
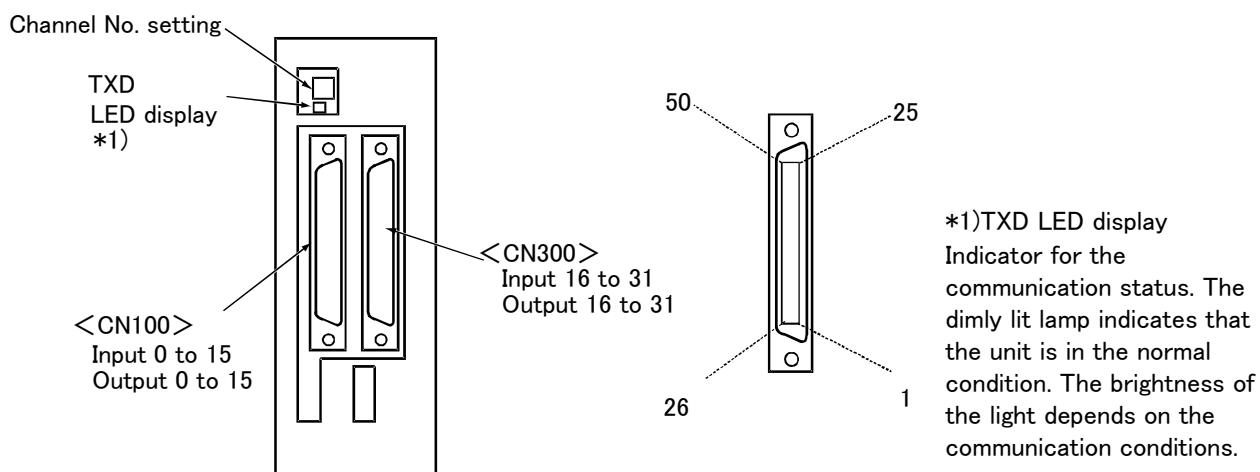

Fig.3-33 : Connection method of expansion parallel I/O unit

### ■ Pin arrangement of the connector



\*2A-RZ361/2 A-RZ371 are 32/32 input-and-output units. (One-station occupancy)

Fig.3-34 : Pin arrangement of the parallel I/O unit

### ■ Assignment of pin number and signal

The assignment range of the general-purpose input-and-output signal is fixed by the setup of the station number. Although the combined use with the parallel I/O interface (2D-TZ368/2D-TZ378) of another option is also possible, please use the setup of the station number by the different number separately.

Table 3-38 : Assignment of pin number and signal

Unit Number	Station number	CN100	CN300
1st set	0	Input : 0 to 15 Output : 0 to 15	Input : 16 to 31 Output : 16 to 31
2nd set	1	Input : 32 to 47 Output : 32 to 47	Input : 48 to 63 Output : 48 to 63
3rd set	2	Input : 64 to 79 Output : 64 to 79	Input : 80 to 95 Output : 80 to 95
4th set	3	Input : 96 to 111 Output : 96 to 111	Input : 112 to 127 Output : 112 to 127
5th set	4	Input : 128 to 143 Output : 128 to 143	Input : 144 to 159 Output : 144 to 159
6th set	5	Input : 160 to 175 Output : 160 to 175	Input : 176 to 191 Output : 176 to 191
7th set	6	Input : 192 to 207 Output : 192 to 207	Input : 208 to 223 Output : 208 to 223
8th set	7	Input : 224 to 239 Output : 224 to 239	Input : 240 to 255 Output : 240 to 255

The connector pin number of the parallel I/O unit of the station number 0 and signal number assignment are shown in [Table 3-39](#) and [Table 3-40](#). If it is set as other station number, please interpret and utilize.

■ Parallel I/O interface (First expansion unit)

Table 3-39 : Connector CN100pin No. and signal assignment list (2A-CBL □□)

Pin No.	Line color	Function name		Pin No.	Line color	Function name	
		General-purpose	Dedicated/power supply, common			General-purpose	Dedicated/power supply, common
1	Orange/Red A		FG	26	Orange/Blue A		FG
2	Gray/Red A		0V:For pins 4-7, 10-13	27	Gray/Blue A		0V:For pins 29-32, 35-38
3	White/Red A		12V/24V:For pins 4-7	28	White/Blue A		12V/24V:For pins 29-32
4	Yellow/Red A	General-purpose output 0	Operating output <sup>Note1)</sup>	29	Yellow/Blue A	General-purpose output 4	
5	Pink/Red A	General-purpose output 1	In servo ON output signal <sup>Note1)</sup>	30	Pink/Blue A	General-purpose output 5	
6	Orange/Red B	General-purpose output 2	Error occurring output signal <sup>Note1)</sup>	31	Orange/Blue B	General-purpose output 6	
7	Gray/Red B	General-purpose output 3	Operation rights output signal <sup>Note1)</sup>	32	Gray/Blue B	General-purpose output 7	
8	White/Red B		0V:For pins 4-7, 10-13	33	White/Blue B		0V:For pins 29-32, 35-38
9	Yellow/Red B		12V/24V:For pins 10-13	34	Yellow/Blue B		12V/24V:For pins 35-38
10	Pink/Red B	General-purpose output 8		35	Pink/Blue B	General-purpose output 12	
11	Orange/Red C	General-purpose output 9		36	Orange/Blue C	General-purpose output 13	
12	Gray/Red C	General-purpose output 10		37	Gray/Blue C	General-purpose output 14	
13	White/Red C	General-purpose output 11		38	White/Blue C	General-purpose output 15	
14	Yellow/Red C		COM0:For pins 15-22 <sup>Note2)</sup>	39	Yellow/Blue C		COM1:For pins 40-47 <sup>Note2)</sup>
15	Pink/Red C	General-purpose input 0	Stop input <sup>Note3)</sup>	40	Pink/Blue C	General-purpose input 8	
16	Orange/Red D	General-purpose input 1	Servo OFF input signal <sup>Note1)</sup>	41	Orange/Blue D	General-purpose input 9	
17	Gray/Red D	General-purpose input 2	Error reset input signal <sup>Note1)</sup>	42	Gray/Blue D	General-purpose input 10	
18	White/Red D	General-purpose input 3	Start input <sup>Note1)</sup>	43	White/Blue D	General-purpose input 11	
19	Yellow/Red D	General-purpose input 4	Servo ON input signal <sup>Note1)</sup>	44	Yellow/Blue D	General-purpose input 12	
20	Pink/Red D	General-purpose input 5	Operation rights input signal <sup>Note1)</sup>	45	Pink/Blue D	General-purpose input 13	
21	Orange/Red E	General-purpose input 6		46	Orange/Blue E	General-purpose input 14	
22	Gray/Red E	General-purpose input 7		47	Gray/Blue E	General-purpose input 15	
23	White/Red E		Reserved	48	White/Blue E		Reserved
24	Yellow/Red E		Reserved	49	Yellow/Blue E		Reserved
25	Pink/Red E		Reserved	50	Pink/Blue E		Reserved

Note1) The dedicated signal is assigned at shipping. It can change with the parameter.

Note2) Sink type:12V/24V(COM),Source type:0V(COM)

Note3) The dedicated input signal (STOP) is assigned at shipping. The signal number is fixing.

Table 3-40 : Connector CN300pin No. and signal assignment list (2A-CBL □□ )

Pin No.	Line color	Function name		Pin No.	Line color	Function name	
		General-purpose	Dedicated/power supply, common			General-purpose	Dedicated/power supply, common
1	Orange/Red A		FG	26	Orange/Blue A		FG
2	Gray/Red A		0V:For pins 4-7, 10-13	27	Gray/Blue A		0V:For pins 29-32, 35-38
3	White/Red A		12V/24V:For pins 4-7	28	White/Blue A		12V/24V:For pins 29-32
4	Yellow/Red A	General-purpose output 16		29	Yellow/Blue A	General-purpose output 20	
5	Pink/Red A	General-purpose output 17		30	Pink/Blue A	General-purpose output 21	
6	Orange/Red B	General-purpose output 18		31	Orange/Blue B	General-purpose output 22	
7	Gray/Red B	General-purpose output 19		32	Gray/Blue B	General-purpose output 23	
8	White/Red B		0V:For pins 4-7, 10-13	33	White/Blue B		0V:For pins 29-32, 35-38
9	Yellow/Red B		12V/24V:For pins 10-13	34	Yellow/Blue B		12V/24V:For pins 35-38
10	Pink/Red B	General-purpose output 24		35	Pink/Blue B	General-purpose output 28	
11	Orange/Red C	General-purpose output 25		36	Orange/Blue C	General-purpose output 29	
12	Gray/Red C	General-purpose output 26		37	Gray/Blue C	General-purpose output 30	
13	White/Red C	General-purpose output 27		38	White/Blue C	General-purpose output 31	
14	Yellow/Red C		COM0:For pins 15-22 <sup>Note1)</sup>	39	Yellow/Blue C		COM1:For pins 40-47 <sup>Note1)</sup>
15	Pink/Red C	General-purpose input 16		40	Pink/Blue C	General-purpose input 24	
16	Orange/Red D	General-purpose input 17		41	Orange/Blue D	General-purpose input 25	
17	Gray/Red D	General-purpose input 18		42	Gray/Blue D	General-purpose input 26	
18	White/Red D	General-purpose input 19		43	White/Blue D	General-purpose input 27	
19	Yellow/Red D	General-purpose input 20		44	Yellow/Blue D	General-purpose input 28	
20	Pink/Red D	General-purpose input 21		45	Pink/Blue D	General-purpose input 29	
21	Orange/Red E	General-purpose input 22		46	Orange/Blue E	General-purpose input 30	
22	Gray/Red E	General-purpose input 23		47	Gray/Blue E	General-purpose input 31	
23	White/Red E		Reserved	48	White/Blue E		Reserved
24	Yellow/Red E		Reserved	49	Yellow/Blue E		Reserved
25	Pink/Red E		Reserved	50	Pink/Blue E		Reserved

Note1) Sink type:12V/24V(COM),Source type:0V(COM)

<Reference> The example of connection with our PLC

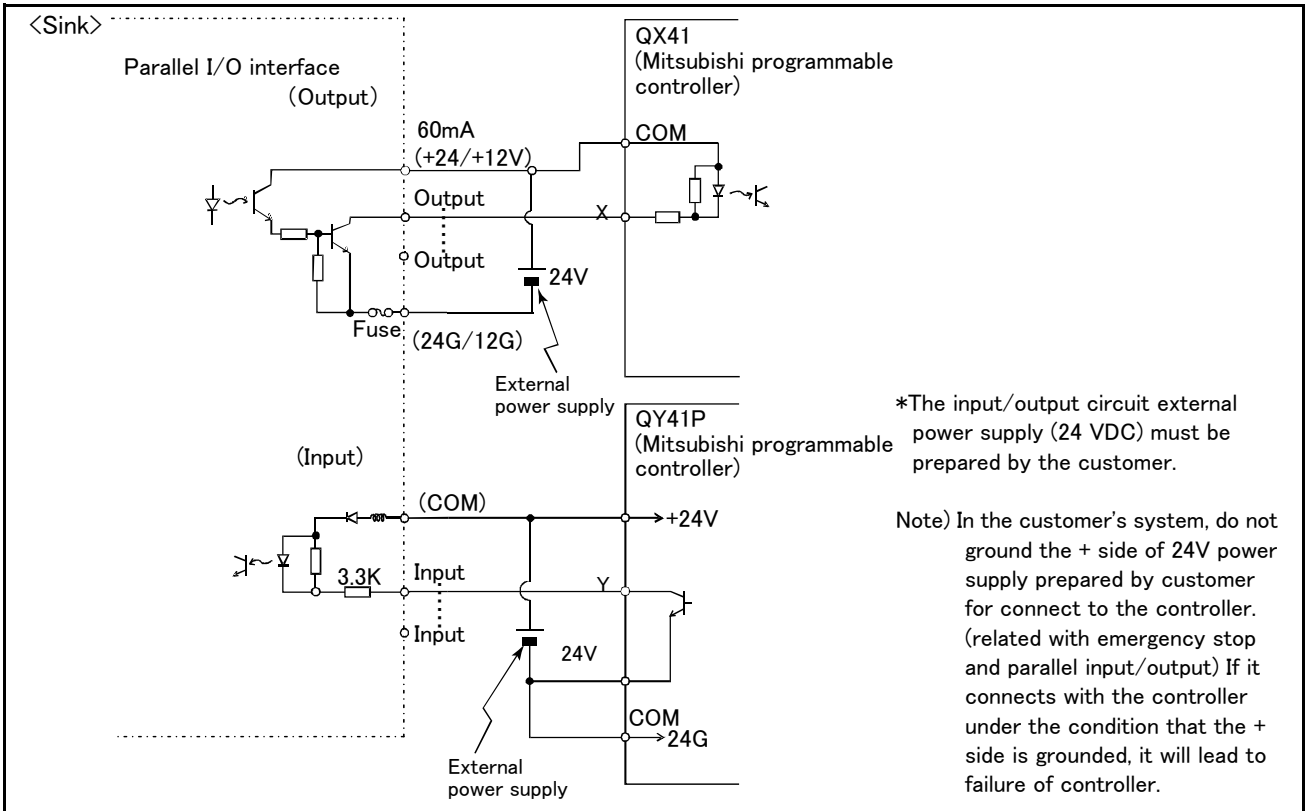

Table 3-41 : Connection with a Mitsubishi PLC (Example of sink type)

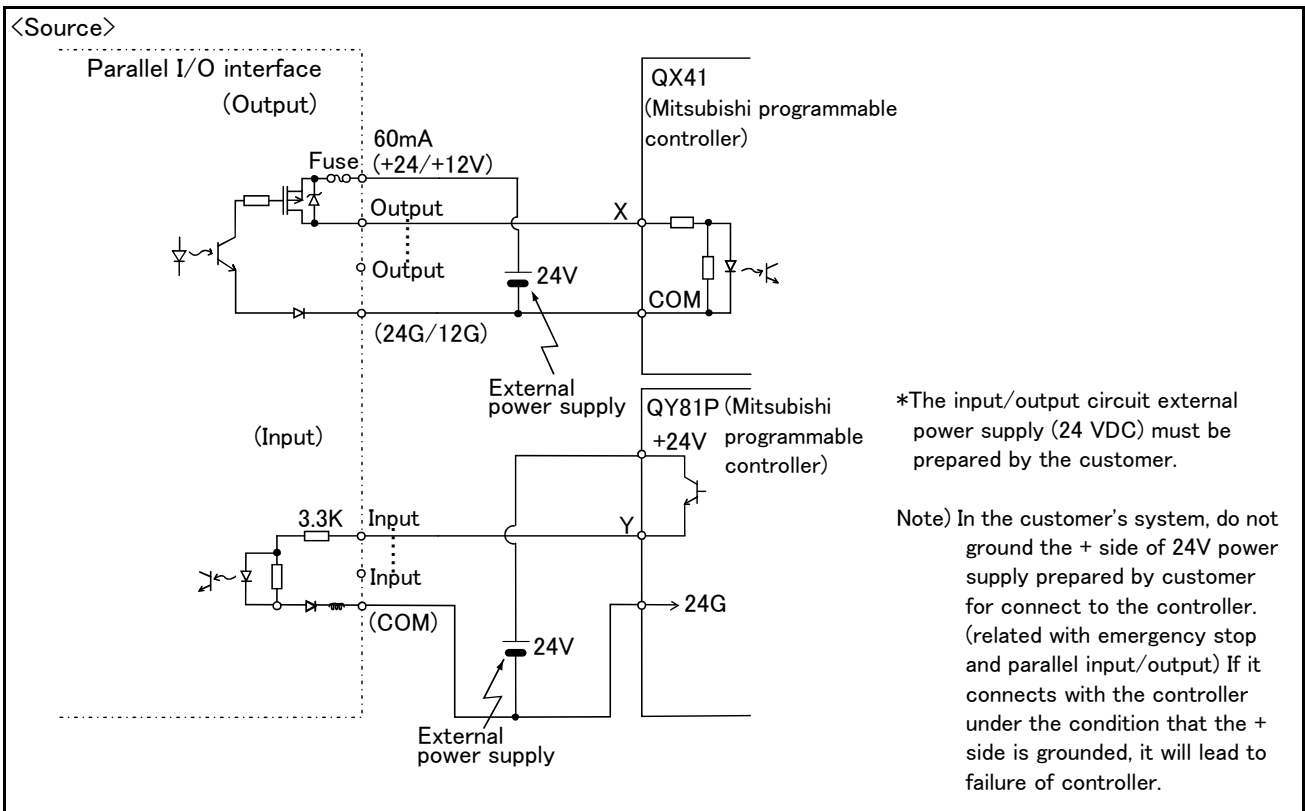

Table 3-42 : Connection with a Mitsubishi PLC (Example of source type)

## (4) External I/O cable

■ Order type: 2A-CBL □□ Note) The numbers in the boxes □□ refer to the length. (05: 5m、15: 15m)

## ■ Outline



This is the dedicated cable used to connect an external peripheral device to the connector on the parallel input/output unit.

One end matches the connector on the parallel input/output unit, and the other end is free. Connect the peripheral device's input/output signal using the free end.

One cable correspond to the input 16 points and output 16 points.

Two cables are needed to connection of (input 32 points and output 32 points) with built-in standard.

## ■ Configuration

Table 3-43 : Configuration device

Part name	Type	Qty.	Mass(kg) <sup>Note1)</sup>	Remarks
External I/O cable	2A-CBL □□	1pc.	0.7(5m) 1.84(15m)	5m or 15m

Note1) Mass indicates one set.

## ■ Specifications

Table 3-44 : Specifications

Items	Specifications
Number of cables x cable size	50 pairs x AWG #28
Total length	5m or 15m

## ■ Connector pin numbers and cable colors

Table 3-45 : Connector pin numbers and cable colors

Pin no.	Cable colors	Pin no.	Cable colors	Pin no.	Cable colors	Pin no.	Cable colors	Pin no.	Cable colors
1	Orange/Red A	11	Orange/Red C	21	Orange/Red E	31	Orange/Blue B	41	Orange/Blue D
2	Gray/Red A	12	Gray/Red C	22	Gray/Red E	32	Gray/Blue B	42	Gray/Blue D
3	White/Red A	13	White/Red C	23	White/Red E	33	White/Blue B	43	White/Blue D
4	Yellow/Red A	14	Yellow/Red C	24	Yellow/Red E	34	Yellow/Blue B	44	Yellow/Blue D
5	Pink/Red A	15	Pink/Red C	25	Pink/Red E	35	Pink/Blue B	45	Pink/Blue D
6	Orange/Red B	16	Orange/Red D	26	Orange/Blue A	36	Orange/Blue C	46	Orange/Blue E
7	Gray/Red B	17	Gray/Red D	27	Gray/Blue A	37	Gray/Blue C	47	Gray/Blue E
8	White/Red B	18	White/Red D	28	White/Blue A	38	White/Blue C	48	White/Blue E
9	Yellow/Red B	19	Yellow/Red D	29	Yellow/Blue A	39	Yellow/Blue C	49	Yellow/Blue E
10	Pink/Red B	20	Pink/Red D	30	Pink/Blue A	40	Pink/Blue C	50	Pink/Blue E

■ Connections and outside dimensions

The sheath of each signal cable (50 lines) is color indicated and marked with dots. Refer to the cable color specifications in "Table 3-45: Connector pin numbers and cable colors" when making the connections.

(Eg.) Pin number: color indication

1 : Orange / Red / A

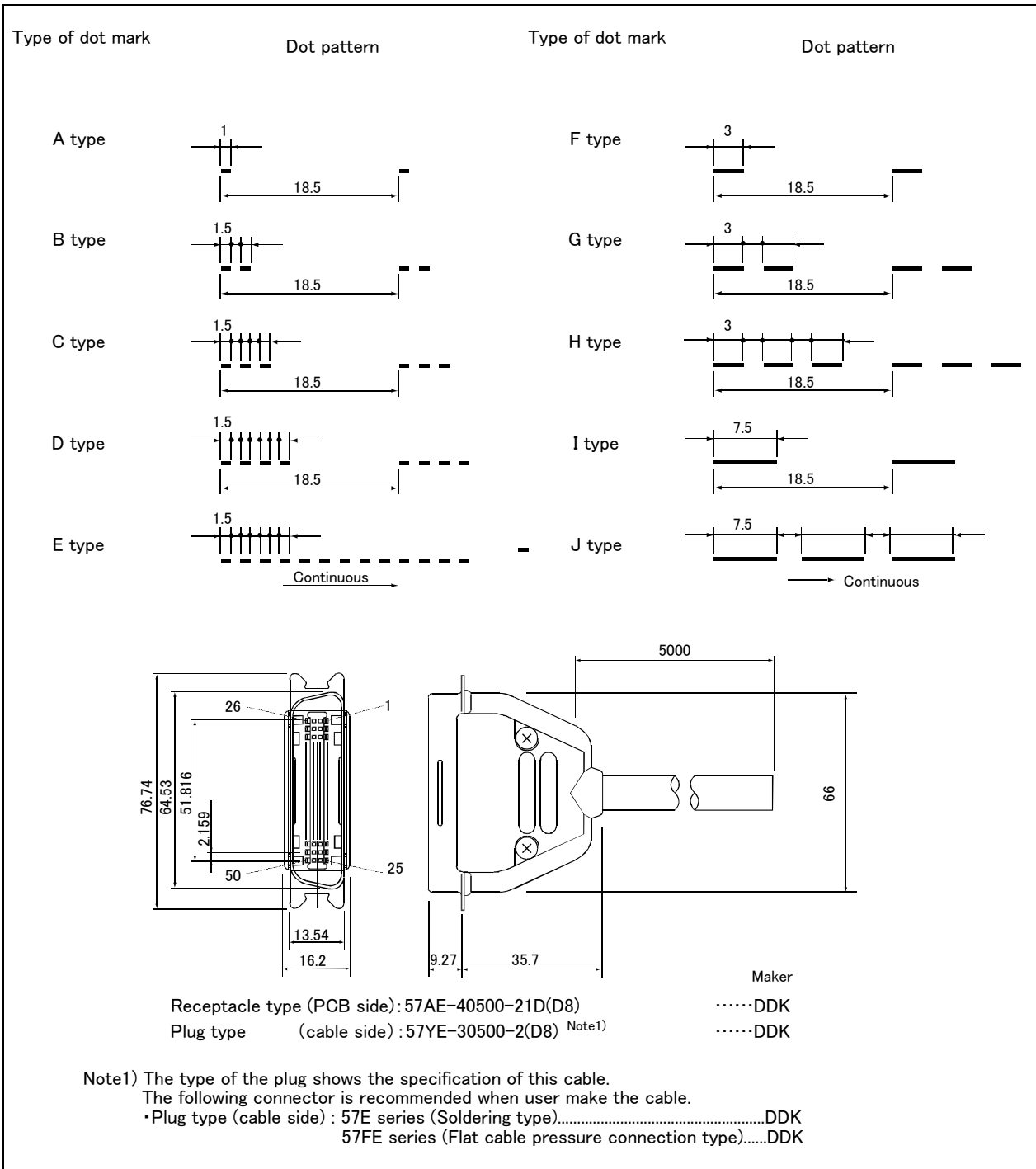
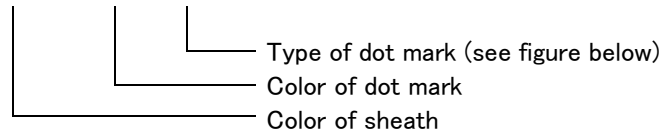

Fig.3-35 : Connections and outside dimensions



(5) CC-Link interface

■ Order type: ● 2D-TZ576

■ Outline



The CC-Link interface is the option interface to not only add bit data to the robot controller, but also to add CC-Link field network function that allows cyclic transmission of word data.

■ Configuration

Table 3-46 : Configuration device

Part name	Type	Qty.	Mass(kg) <sup>Note1)</sup>	Remarks
CC-Link interface	TZ576	1	0.6	
Manual	BFP-A8634	1	-	CD-ROM
Ferrite core	E04SR301334	2	-	Be sure to install this for noise countermeasure.
Cable clamp	AL4	2	-	
	AL5	2	-	
On-line connector for communication	A6CON-LJ5P	1	-	
Terminal resistor	A6CON-TR11N	1	-	Resistance value: 100Ω
One-touch connector plug for communication	A6CON-L5P	2	-	

Note1) Mass indicates one set.

Table 3-47 : Procured by the customer

Part name	Type	Qty.	Remarks
Master station	FX3U-16CCL-M (FX series)	1	
	RJ61BT11 (R series)		
	QJ61BT11 (Q series)		
	QJ61BT11N (Q series)		
	AJ61QBT11 (QnA series)		
	A1SJ61QBT11 (QnAS series)		
	AJ61BT11 (A series)		
	A1SJ61BT11 (AnS series)		
	A80BD-J61BT11 (personal computer board)		
Communication cable	-	1	Ddedicated cable

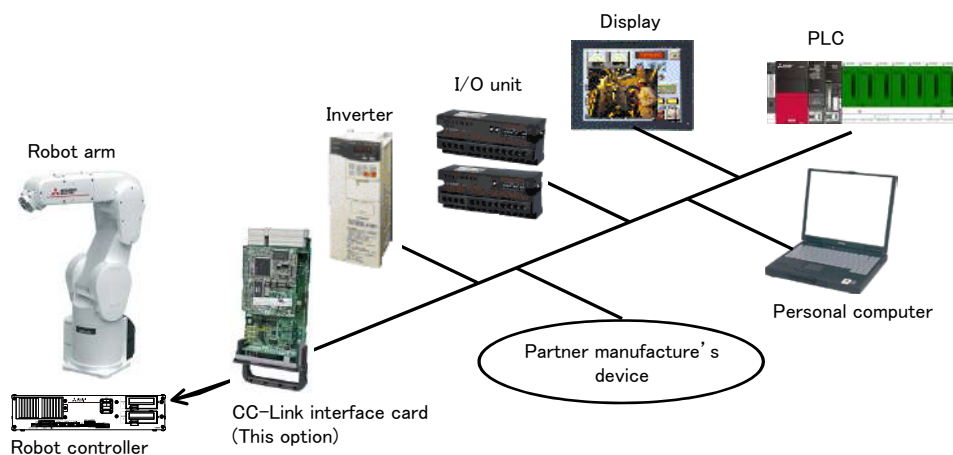

Fig.3-36 : Example of CC-Link Product Configuration

### ■ Specifications

Table 3-48 : Specifications

Item		Specifications				Remarks	
Communication function		Bit data and word data can be transmitted.				Word data are used by the registers.	
Station type		Intelligent device station <sup>Note1)</sup>					
Support station		Local station				No master station function	
The version corresponding to CC-Link		Ver.2				The extended cyclic setup is possible.	
Mountable option slot		Slot 1, 2					
Number of mountable CC-Link interface cards		1				Multiple CC-Link interface cards cannot be inserted.	
Number of stations		1 to 64 stations				When four stations are occupied, continuous station numbers are used. The station numbers are set by a DIP switch.	
Transmission speed		10M/5M/2.5M/625K/156K bps				This is set by the rotary SW.	
Station number		1 to 64				When two or more stations are occupied, continuous station numbers are used.	
Number of occupied stations		1/2/3/4					
Extended cyclic setup		1/2/4/8					
Maximum link point		Remote I/O (RX, RY).	Each 896 points				The two last cannot be used.
		Remote register (RW <sub>r</sub> , RW <sub>w</sub> )	Each 128 register				16 bits/register
Extended cyclic setup		–	1 fold setup	2 fold setup	3 fold setup	4 fold setup	
Link point per set	When one station is occupied	Remote I/O (RX, RY).	32 point	32 point	64 point	128 point	
		Remote register ( RW <sub>w</sub> )	4 word	8 word	16 word	32 word	
		Remote register (RW <sub>r</sub> )	4 word	8 word	16 word	32 word	
	When two stations is occupied	Remote I/O (RX, RY).	64 point	96 point	192 point	384 point	
		Remote register ( RW <sub>w</sub> )	8 word	16 word	32 word	64 word	
		Remote register (RW <sub>r</sub> )	8 word	16 word	32 word	64 word	
	When three stations is occupied	Remote I/O (RX, RY).	96 point	160 point	320 point	640 point	
		Remote register ( RW <sub>w</sub> )	12 word	24 word	48 word	96 word	
		Remote register (RW <sub>r</sub> )	12 word	24 word	48 word	96 word	
	When four stations is occupied	Remote I/O (RX, RY).	128 point	224 point	448 point	896 point	
		Remote register ( RW <sub>w</sub> )	16 word	32 word	64 word	128 word	
		Remote register (RW <sub>r</sub> )	16 word	32 word	64 word	128 word	
Number of the maximum occupancy station		4 stations					
The I/O first number of the robot controller.		No. 6000 – The number corresponding to the station number by the setup of the parameter "CCFIX."					

Note1) The CC-Link interface supports neither the transient transmission function nor the FX series.

**■ Functions**

## (1) Communication function

- The number of usable points is 896 points maximum for bit control and 128 points maximum for word control.

## (2) Easy setup

- The CC-Link interface card can be set by a rotary switch or DIP switch.
- No separate space is required to mount the CC-Link interface card as it is embedded in the robot controller (can only be mounted into slot 2).
- Easy wiring since only four terminals need to be connected.
- Dedicated commands have been added to MELFA-BASIC V, VI (robot programming language); thus, no complex interface programming is required.

## (3) High-speed response

- The link scan time when connecting 64 stations is approximately 7.2 ms.
- A transmission speed can be selected from 10M, 5M, 2.5M, 625K and 156K bps according to the transmission distance.

(6) SD memory card

■ Order type: 2F-2GBSD

■ Outline



This card is used as an extended memory.  
Insert this card to the slot (SD CARD) on the front of the controller, and store robot programs, logging data, or other data.

■ Configuration

Table 3-49 : Configuration device

Part name	Type	Qty.	Remarks
SD memory card	2F-2GBSD	1	Memory card capacity: 2GB

### 3.10 Maintenance parts

The consumable parts used in the controller are shown in [Table 3-50](#). Purchase these parts from your dealer when required. Some Mitsubishi-designated parts differ from the maker's standard parts. Thus, confirm the part name, robot arm and controller serial No. and purchase the parts from your dealer.

Table 3-50 : Controller consumable parts list

No.	Name	Type <sup>Note1)</sup>	Qty.	Usage place	Supplier
1	Filter	BKOFA0773H42	1	Inside the filter cover	Mitsubishi Electric
2	Lithium battery	Q6BAT	1	Robot CPU unit: For Q172DSRCPU (CR800-Q controller only)	Mitsubishi Electric

Note1) Confirm the robot arm serial No., and contact the dealer or service branch of Mitsubishi Electric Co., for the type.

## 4 Software

## 4.1 List of commands

The available new functions in MELFA-BASIC VI are given in [Table 4-1](#).

Table 4-1 : List of MELFA-BASIC VI commands

Type	Class	Function	Input format (example)
Structured programming	Function procedure	Defines the Function procedure. Function procedure summarizes a series of processing enclosed by the Function statement and the FEnd statement.	Function M Func(M1, M2) M3=M1+M2 Func=M3 Exit Function FEnd
Library function	#Include statement	Reads the designated program.	#Include "PRG1"
Position and operation control	Interpolation operation	Moves to the multiple designated positions with the designated interpolation operations and options.	Move L, P1, P2, P3, Spd=50
	Joint interpolation	Moves to the designated position with joint interpolation.	Mov P1
	Linear interpolation	Moves to the designated position with linear interpolation.	Mvs P1
	Circular interpolation	Moves along a designated arc (start point → passing point → start point (end point)) with 3-dimensional circular interpolation (360 degrees).	Mvc P1,P2,P1
		Moves along a designated arc (start point → passing point → end point) with 3-dimensional circular interpolation.	Mvr P1,P2,P3
		Moves along the arc on the opposite side of a designated arc (start point → reference point → end point) with 3-dimensional circular interpolation.	Mvr2 P1,P9,P3
		Moves along a set arc (start point → end point) with 3-dimensional circular interpolation.	Mvr3 P1,P9,P3
		Speed designation	Designates the speed for various interpolation operations with a percentage (0.1% unit).
		Designate the speed for joint interpolation operation with a percentage (0.1% unit).	JOvrd 100
		Designates the speed for linear and circular interpolation with a numerical value (mm/s unit).	Spd 123.5
		Designates the acceleration/deceleration time as a percentage in respect to the predetermined maximum acceleration/deceleration. (1% unit)	Accel 50,80
		Automatically adjusts the acceleration/deceleration according to the parameter setting value.	Oadl ON
		Sets the hand and work conditions for automatic adjustment of the acceleration/deceleration.	Loadset 1,1
	Operation	Adds a process unconditionally to the operation.	Wth
		Adds a process conditionally to the operation.	WthIf
		Designates smooth operation.	Cnt 1,100,200
		Performance of movement is upgraded corresponding to the application.	MvTune 4
		Designates the positioning completion conditions with a No. of pulses.	Fine 200
		Designates the positioning completion conditions with a distance in a straight line	Fine 1, P
		Turns the servo power ON/OFF for all axes.	Servo OFF
		Limits the operation of each axis so that the designated torque is not exceeded.	Torq 4,10
	Position control	Designates the base conversion data.	Base P1
		Designates the tool conversion data.	Tool P1
	Float control	The robot arm rigidity is lowered and softened. (XYZ coordinate system)	Cmp Pos ,&B00000011
		The robot arm rigidity is lowered and softened. (JOINT coordinate system)	Cmp Jnt ,&B00000011
		The robot arm rigidity is lowered and softened. (TOOL coordinate system)	Cmp Tool ,&B00000011
		The robot arm rigidity is returned to the normal state.	Cmp Off
The robot arm rigidity is designated.		CmpG 1.0,1.0,1.0,1.0,1.0,1.0,1.0,1.0	

Type	Class	Function	Input format (example)	
Position and operation control	Pallet	Defines the pallet.	Def Plt 1,P1,P2,P3,P4,5,3,1	
		Operates the pallet grid point position.	Plt 1,M1	
	Singular point passage	Move to a specified position using linear interpolation passing through a singular point.	Mvs P1 Type 0,2	
	Branching	Branches unconditionally to the designated place.	Branches according to the designated conditions.	GoTo *LBL If M1=1 Then GoTo *L100 Else GoTo *L200 EndIf
			Repeats until the designated end conditions are satisfied.	For M1=1 To 10  Next M1
		Repeats while the designated conditions are satisfied.	While M1<10  WEnd	
		Branches corresponding to the designated expression value.	On M1 GoTo *La1, *Lb2, *Lc3	
		Executes program block corresponding to the designated expression value.	Select Case 1  Break Case 2  Break End Select	
		Moves the program process to the next line.	Skip	
		Collision detection	Set to enable/disable the collision detection.	ColChk On/Off
	Set the detection level of the collision detection.		ColLvl 100,80,.....	
	Subroutine	Executes the designated subroutine. (Within program)	GoSub *L200	
		Returns from the subroutine.	Return	
		Executes the designated program.	CallP "P10",M1,P1	
		Defines the program argument executed with the CALLP command.	FPrm M10,P10	
		Executes the subroutine corresponding to the designated expression value.	On M1 GoSub*La1,*La2,*La3	
	Interrupt	Defines the interrupt conditions and process.	Def Act 1, M1=1 GoTo *L123	
		Enables/disables the interrupt.	Act 1=1	
		Defines the start line of the program to be executed when an interrupt is generated from the communication line.	On Com(1) GoSub *LABC	
		Enables the interrupt from the communication line.	Com(1) On	
		Disables the interrupt from the communication line.	Com(1) Off	
		Stops the interrupt from the communication line.	Com(1) Stop	
	Wait	Designates the wait time, and the output signal pulse output time. (0.01s unit)	Dly 0.5	
		Waits until the variable becomes the designated value.	Wait M_In(20)=1	
	Stop	Stops the program execution.	Hlt	
		Generates an error. During program execution, continue, stop or servo OFF can be designated.	Error 9000	
	End	Ends the program execution.	End	
	Hand	Hand open	Opens the designated hand.	HOpen 1
		Hand close	Closes the designated hand.	HClose 1
	Input/output	Assignment	Defines the input/output variables.	Def IO PORT1=Bit,99
		Input	Retrieves the general-purpose input signal.	M1=M_In (78)
		Output	Calls out the general-purpose output signal.	M_Out(23) =0
Parallel execution	Mechanism designation	Acquires the mechanism with the designated mechanism No.	GetM 1	
		Releases the mechanism with the designated mechanism No.	RelM 1	
	Selection	Selects the designated program for the designated slot.	XLoad 2,"P102"	
	Start/stop	Carries out parallel execution of the designated program.	XRun 3,"100",0	
		Stops parallel execution of the designated program.	XStp 3	
	Returns the designated program's execution line to the head and enters the program selection enabled state.	XRst 3		

Type	Class	Function	Input format (example)
Others	Definition	Defines the integer type or real number type variable.	Def Inte KAISUU
		Defines the character string variable.	Def Char MESSAGE
		Defines the layout variable. (Up to 3-dimensional possible)	Dim PDATA(2,3)
		Defines the joint variable.	Def Jnt TAIHI
		Defines the position variable.	Def Pos TORU
		Defines the function.	Def FN TASU(A,B)=A+B
	Clear	Clears the general-purpose output signal, variables in program, variables between programs, etc.	Clr 1
	File	Opens a file.	Open "COM1:" AS #1
		Closes a file.	Close #1
		Inputs data from a file.	Input #1,M1
		Outputs data to a file.	Print #1,M1
	Comment	Describes a comment.	Rem "ABC"
	Label	Indicates the branching destination.	*SUB1



## 4.2 List of parameters

Show the main parameter in the [Table 4-2](#).

Table 4-2 : List of parameters

Parameter		Details
Standard tool coordinates.	MEXTL	Set the default value for the tool data. Unit: mm or deg.
Standard base coordinates	MEXBS	Set the relation of the world coordinate system and robot coordinate system. Unit: mm or deg.
XYZ operation range	MEPAR	Designate the overrun limit value for the world coordinate system.
JOINT operation range	MEJAR	Set the overrun limit value for each joint axis.
Free plane limit		This is the overrun limit set with the free plane. Create a plane with the three coordinates x1, y1, z1 to x3, y3, z3, and set the outer side of the plane as the outside operation range (error). The following three types of parameters are used.
	SFC1P : SFC8P	Eight types of free plane limits can be set in SFC1P to SFC8P. There are nine elements, set in the order of x1, y1, z1, x2, y2, z2, x3, y3, z3.
	SFC1ME : SFC8ME	Designate which mechanism to use eight types of set free plane limits. The mechanism No. to use is set with 1 to 3.
	SFC1AT : SFC8AT	Set the validity of the eight types of set free plane limits. (Valid 1/Valid 2/invalid = 1/-1/0)
User-defined area		An area (cube) defined with two XYZ coordinate points can be designated and that area set as the outside operation range. Furthermore, a signal can be output when the axis enters that area. Up to 32 types of area can be designated.
	AREA1CS : AREA32CS	Specify the coordinate system of the user definition area *. 0: Base coordinate system (conventional compatibility) 1: Robot coordinate system
	AREA1P1 : AREA32P1	Designated the 1st point of the area. There are eight elements, set in the order of x, y, z, a, b, c, L1, L2. (L1 and L2 are the additional axes.)
	AREA1P2 : AREA32P2	Designated the 2nd point of the area. There are eight elements, set in the order of x, y, z, a, b, c, L1, L2. (L1 and L2 are the additional axes.)
	AREA1ME : AREA32ME	Designate which mechanism to use the 32 types of set area. The mechanism No. to use is set with 1 to 3.
	AREA1AT : AREA32AT	Designate the area check type. (Invalid/zone/interference = 0/1/2) Zone: The dedicated output signal USRAREA turns ON. Interference: An error occurs..
	Automatic return setting	RETPATH
Buzzer ON/OFF	BZR	Designate whether to the turn buzzer ON or OFF.
Jog setting	JOGJSP	Designate the joint jog and step operation speed. (Set dimension H/L amount, max. override.)
	JOGPSP	Designate the linear jog and step operation speed. (Set dimension H/L amount, max. override.)
Jog speed limit value	JOGSPMX	Limit the operation speed during the teaching mode. Max. 250[mm/s]
Hand type	HANDTYPE	Set the hand type of the single/double solenoid, and the signal No. (Single/double = S/D) Set the signal No. after the hand type. Example) D900
Stop input B contact designation	INB	Change the dedicated input (stop) to either of normal open or normal close.

Parameter		Details
User-designated origin	USERORG	Designate the user-designated origin position.
Program selection memory	SLOTON	Select the program selected previously when initializing the slot. The non-selected state will be entered when not set.
Communication setting	CBAU232	Set the baud rate.
	CLEN232	Set the character length.
	CPRTY232	Set the parity.
	CSTOP232	Set the stop bit.
	CTERM232	Set the end code.
Slot table	SLT1 : SLT32	Make settings (program name, operation type, order of priority, etc.) for each slot during slot initialization.
No. of multi-tasks	TASKMAX	Designate the No. of programs to be executed simultaneously. (Max. 32)
Multi CPU system setting	QMLTCPUN	At the multi CPU system, set the number of CPU units with which the standard base unit is equipped.
	QMLTCPUn	Sets the high-speed communication area of each CPU unit in the multi CPU system.
	QMLTCPUS	Sets the input offset of each CPU unit in the multi CPU system.
Select the function of singular point adjacent alarm	MESNGLSW	Designate the valid/invalid of the singular point adjacent alarm. (Invalid/Valid =0/1) When this parameter is set up "VALID", this warning sound is buzzing even if parameter: BZR (buzzer ON/OFF) is set up "OFF".
Display language	LNG	Sets the display language on the RT ToolBox3 (option).

## 5 Instruction Manual

### 5.1 The details of each instruction manuals

The contents and purposes of the documents enclosed with this product are shown below.

Use these documents according to the application.

For special specifications, a separate instruction manual describing the special section may be enclosed.

Manual name	Description
Safety Manual	Explains the common precautions and safety measures to be taken for robot handling, system design and manufacture to ensure safety of the operators involved with the robot.
Standard Specifications	Explains the product's standard specifications, factory-set special specifications, option configuration and maintenance parts, etc. Precautions for safety and technology, when incorporating the robot, are also explained.
Robot Arm Setup & Maintenance	Explains the procedures required to operate the robot arm (unpacking, transportation, installation, confirmation of operation), and the maintenance and inspection procedures.
Controller setup, basic operation, and maintenance	Explains the procedures required to operate the controller (unpacking, transportation, installation, confirmation of operation), basic operation from creating the program to automatic operation, and the maintenance and inspection procedures.
Detailed explanations of functions and operations	Explains details on the functions and operations such as each function and operation, commands used in the program, connection with the external input/output device, and parameters, etc.
Troubleshooting	Explains the causes and remedies to be taken when an error occurs. Explanations are given for each error No.
Additional axis function	Explains the specifications, functions and operations of the additional axis control.
Tracking Function	Explains the control function and specifications of conveyor tracking.
GOT Direct Connection Extended Function	Explains the detailed description of data configuration of shared memory, monitoring, and operating procedures about the GOT (standalone type robot).
iQ Platform Supporting Extended Function	Explains the detailed description of data configuration of shared memory, monitoring, and operating procedures about the PLC (iQ Platform compatible type robot).
Ethernet Function	Explains the measures to perform communication with personal computers on Ethernet with the TCP/IP protocol.

## 6 Safety

### 6.1 Safety

Measures to be taken regarding safety of the industrial robot are specified in the “Labor Safety and Sanitation Rules”. Always follow these rules when using the robot to ensure safety.

#### 6.1.1 Self-diagnosis stop functions

This robot has the self-diagnosis stop functions shown in [Table 6-1](#) and the stop functions shown in [Table 6-2](#) for safe use.

Table 6-1 : Self-diagnosis stop functions

No.	Function		Details	Remarks
1	Overload protection function		Activates when the total servo current time exceeds the specified value.	The drive circuit is shut off. The robot stops, and an alarm displays.
2	Overcurrent diagnosis function		Activates when an overcurrent flows to the motor circuit.	The drive circuit is shut off. The robot stops, and an alarm displays.
3	Encoder disconnection diagnosis function		Activates when the encoder cable is disconnected.	The drive circuit is shut off. The robot stops, and an alarm displays.
4	Deflection over diagnosis function		Activates when an error occurs between the command value and actual position, and the error exceeds the specified amount.	The drive circuit is shut off. The robot stops, and an alarm displays.
5	AC power voltage drop diagnosis function		Activates when the AC power voltage drops below the specified value.	The drive circuit is shut off. The robot stops, and an alarm displays.
6	CPU error detection function		Activates when an error occurs in the CPU.	The drive circuit is shut off. The robot stops, and an alarm displays.
7	Overrun prevention function	Software limit detection	This is the limit provided by the software to enable operation only in the operation range.	The drive circuit is shut off. The robot stops, and an alarm displays.
		Mechanical stopper	This is the mechanical stopper provided outside the software.	The robot mechanically stops, and function 1 or 2 activates.

Table 6-2 : List of stop functions

Stop function	Teaching pendant	External input	Details
Emergency stop	○	○	The servo power is shut off and the mechanical brakes activate to stop the robot by stopping operation in an emergency. To recover, reset the alarm, and turn the servo ON with the servo ON command.
Stop	○	○	The robot immediately decelerates to stop by stopping operation as usual. Note that the servo power is not shut off. Use this when using the collision evasion sensor, etc.

### 6.1.2 External input/output signals that can be used for safety protection measures

Table 6-3 : External input/output signals that can be used for safety protection measures

Signal	Connection point	Parameter	Functions	Usage method	
Input	External emergency stop <small>Note1)</small>	Connector CNUSR11	-	This servo power is shut off, and the robot stops immediately.	Externally installed emergency stop switch. Stopping at high-level error occurrence.
	Door switch input <small>Note1)</small>				The door switch of the safe protection fence.
	Stop	CR800-D: Parallel I/O unit or interface CR800-R/Q: Sequencer unit	STOP, STOP2	The program execution is stopped, and the robot stops. The servo power is not shut off.	The robot is stopped when a peripheral device fault occurs. The servo power is not shut off.
	Servo OFF		SRVOFF	The servo power can be shut off.	The robot is stopped when a peripheral device fault occurs. The servo power is also shut off.
	Automatic operation enable		AUTOENA	Disables automatic operation when inactive.	Door switch on safety protection fence.
Output	Emergency stop output	Connector CNUSR11	-	Outputs the input signal of external emergency stop or emergency stop switch of T/B turned on.	Display and warn the pilot lamp, the input signal of external emergency stop or the emergency stop switch of T/B turned on.
	In servo ON	CR800-D: Parallel I/O unit or interface CR800-R/Q: Sequencer unit	SRVON	The servo power ON/OFF state is output.	The servo power ON/OFF state is shown and alerted with the display lamps.
	Waiting		STOP, STOP2	Outputs that the robot is temporarily stopped.	The temporary stop state is shown and alerted with the display lamps.
	In alarm	Connector CNUSR11	ERRRESET	Outputs when an alarm occurs in the robot.	The alarm state is shown and alerted with the display lamps.

Note1) The external emergency stop input, door switch input, and mode selector switch input are provided with the redundancy of normally closed contacts for safety. Thus, if the emergency stop input circuit is opened when the robot is started up, the robot will not operate. Refer to [Page 190, "6.1.7 Examples of safety measures"](#) for details. And, refer to [Page 136, "\(1\) Automatic Operation/Jog Operation/Brake Release and Necessary Switch Settings"](#) for the function of the door switch input and the mode selector switch input.

### 6.1.3 Precautions for using robot

The safety measures for using the robot are specified in the "Labor Safety and Sanitation Rules". An outline of the rules is given below.

#### (1) Robot installation

- Secure sufficient work space required to safely perform work such as teaching and maintenance related to the robot.
- Install the controller outside the robot's motion space. (If a safety fence is provided, install outside the fence.)
- Install the controller where the entire robot operation can be viewed.
- Install display lamps, etc., to indicate the robot's operation state.
- Securely fix the robot arm onto the fixing table with the designated bolts.

#### (2) Prevention of contact with operator

- Install a safety fence or enclosure so that the operator cannot easily enter the robot's motion space.
- Install an interlock function that will stop the robot if the safety fence or enclosure door is opened.

#### (3) Work procedures

- Create and observe work procedures for the robot teaching, operation, inspection and emergencies.
- Create hand signals to be followed when several operators are working together.
- Create displays such as "Teaching in Progress" and "Inspection in Progress" to be put up when an operator is in the robot's motion space so that other operators will not operate the operation panel (controller, control panel).

## (4) Training

- Train the operators about the operations, maintenance and safety required for the robot work.
- Only trained and registered operators must operate the robot. Participation in the "Special training for industrial robots" sponsored by the Labor Safety and Sanitation Committee, etc., is recommended for safety training.

## (5) Daily inspection and periodic inspection

- Always inspect the robot before starting daily operations and confirm that there are no abnormalities.
- Set the periodic inspection standards in view of the robot's ambient environment and operation frequency, and perform periodic inspections.
- Make records when periodic inspections and repairs have been done, and store the records for three or more years.

## 6.1.4 Safety measures for automatic operation

- (1) Install safety fences so that operators will not enter the operation area during operation and indicate that automatic operation is in progress with lamps, etc.
- (2) Create signals to be given when starting operation, assign a person to give the signal, and make sure that the operator follows the signals.

## 6.1.5 Safety measures for teaching

Observe the following measures when teaching, etc., in the robot's operation range.

- (1) Specify and follow items such as procedures related to teaching work, etc.
- (2) Take measures so that operation can be stopped immediately in case of trouble, and measures so that operation can be restarted.
- (3) Take measures with the robot start switch, etc., to indicate that teaching work is being done.
- (4) Always inspect that stop functions such as the emergency stop device before starting the work.
- (5) Immediately stop the work when trouble occurs, and correct the trouble.
- (6) Take measures so that the work supervisor can immediately stop the robot operation when trouble occurs.
- (7) The teaching operator must have completed special training regarding safety. (Training regarding industrial robots and work methods, etc.)
- (8) Create signals to be used when several operators are working together.

## 6.1.6 Safety measures for maintenance and inspections, etc.

Turn the power OFF and take measures to prevent operators other than the relevant operator from pressing the start switch when performing inspections, repairs, adjustments, cleaning or oiling.

If operation is required, take measures to prevent hazards caused by unintentional or mistaken operations.

- (1) Specify and follow items such as procedures related to maintenance work, etc.
- (2) Take measures so that operation can be stopped immediately in case of trouble, and measures so that operation can be restarted.
- (3) Take measures with the robot start switch, etc., to indicate that work is being done.
- (4) Take measures so that the work supervisor can immediately stop the robot operation when trouble occurs.
- (5) The operator must have completed special training regarding safety. (Training regarding industrial robots and work methods, etc.)
- (6) Create signals to be used when several operators are working together.

### 6.1.7 Examples of safety measures

Two emergency-stop input circuits are prepared on the user wiring terminal block of the controller.

The safety measure examples are shown in Fig. 6-1 to Fig. 6-4. Create a circuit as shown below for safety measures. In addition, the figure shows the normal state which is not in the emergency stop state.

[Note] · In the emergency-stop related wiring by the customer, if the coil (is not the contact points) of the relay prepared by the customer is connected to the controller, please be sure to implement the measure against the noise by the customer in the coil section. And, please also take the lifetime of noise suppression parts into consideration.

- Electric specification of the emergency-stop-related output terminal: 24V DC or less, related current 100mA or less.
- In the customer's system, do not ground the + side of 24V power supply prepared by customer for connect to the controller. (related with emergency stop and parallel input/output) If it connects with the controller under the condition that the + side is grounded, it will lead to failure of controller.

<Wiring example 1>: Connect the emergency stop switch of peripheral equipment to the controller.

The power supply for emergency stop input uses the power supply in the controller.

<Operation of the emergency stop>

If the emergency stop switch of peripheral equipment is pushed, the robot will also be in the emergency stop state.

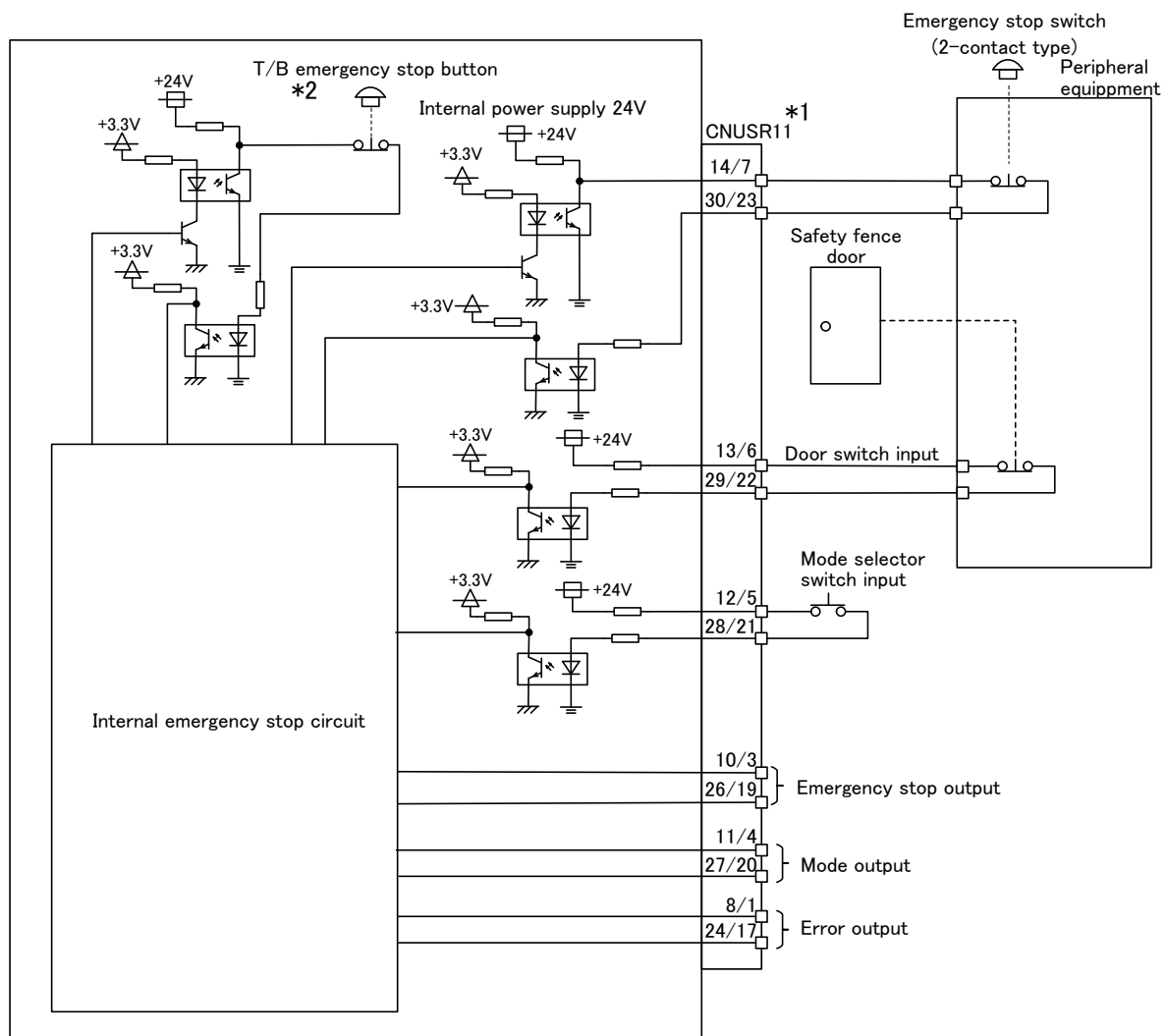

\*1) The CNUSR11 connector is a two-level terminal block, indicating that there are two circuits (channels). Two terminals (cable insertion holes) need to be used for one circuit.

\*2) The T/B emergency stop button connected with the controller.

Fig.6-1 : Example of safety measures (wiring example 1)

<Wiring example 2>: Connect the emergency stop switch, and door switch of peripheral equipment to the controller.  
 The power supply for emergency stop input uses the power supply in the controller. Monitor the emergency stop state by the peripheral equipment side.  
 <Operation of the emergency stop>  
 If the emergency stop switch of peripheral equipment is pushed, the robot will also be in the emergency stop state.  
 When the controller power is OFF, the peripheral devices are in the emergency stop state.

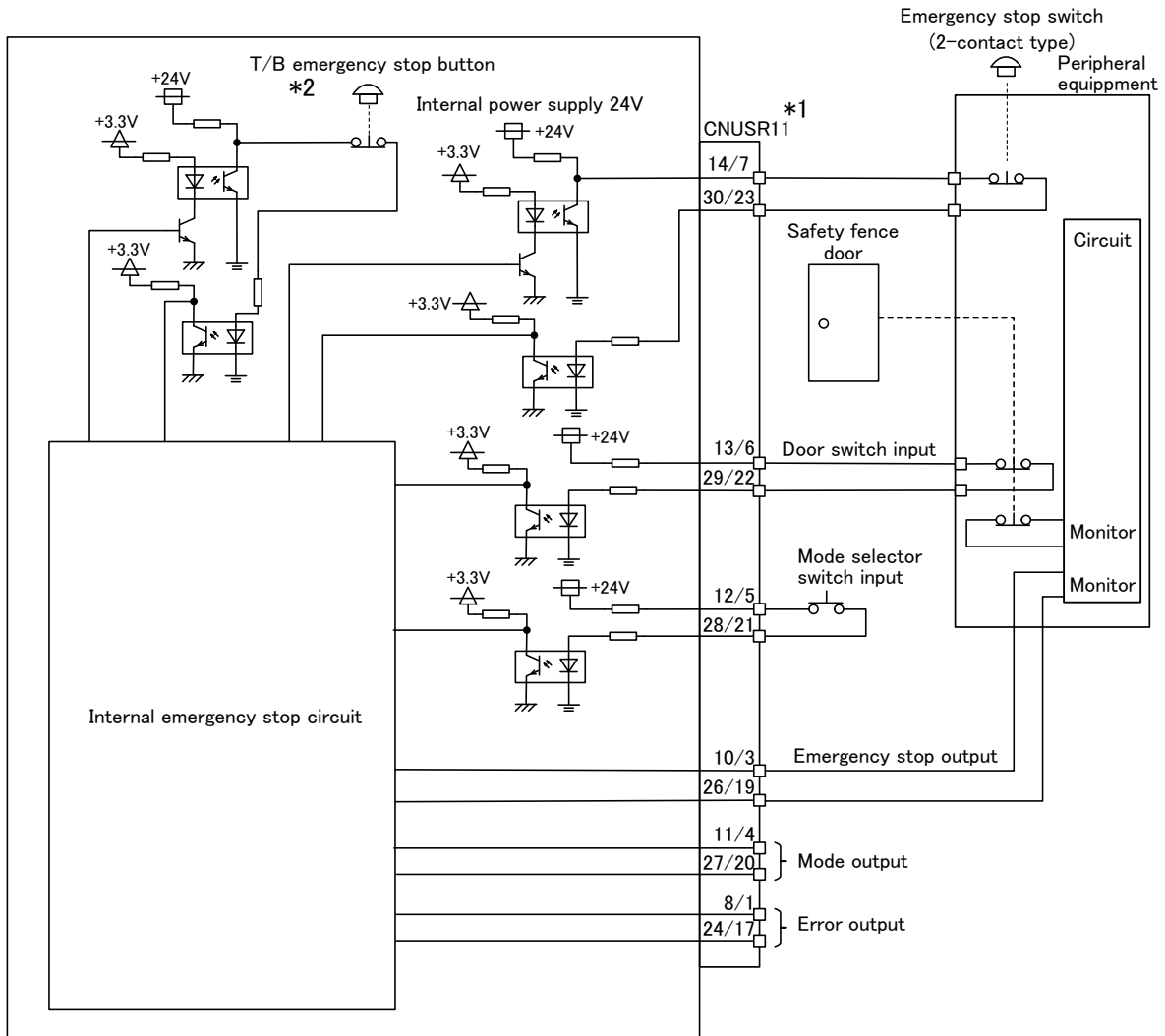

\*1) The CNUSR11 connector is a two-level terminal block, indicating that there are two circuits (channels). Two terminals (cable insertion holes) need to be used for one circuit.  
 \*2) The T/B emergency stop button connected with the controller.

Fig.6-2 : Example of safety measures (wiring example 2)



<Wiring example 3>: Connect the emergency stop switch of peripheral equipment, and the door switch to two controllers, and it interlocks. The power supply for emergency stop input uses the power supply of peripheral equipment. Monitor the emergency stop state by the peripheral equipment side.

<Operation of the emergency stop>

If the emergency stop switch of peripheral equipment is pushed, the robot will also be in the emergency stop state. When the controller power is OFF, the peripheral devices are in the emergency stop state.

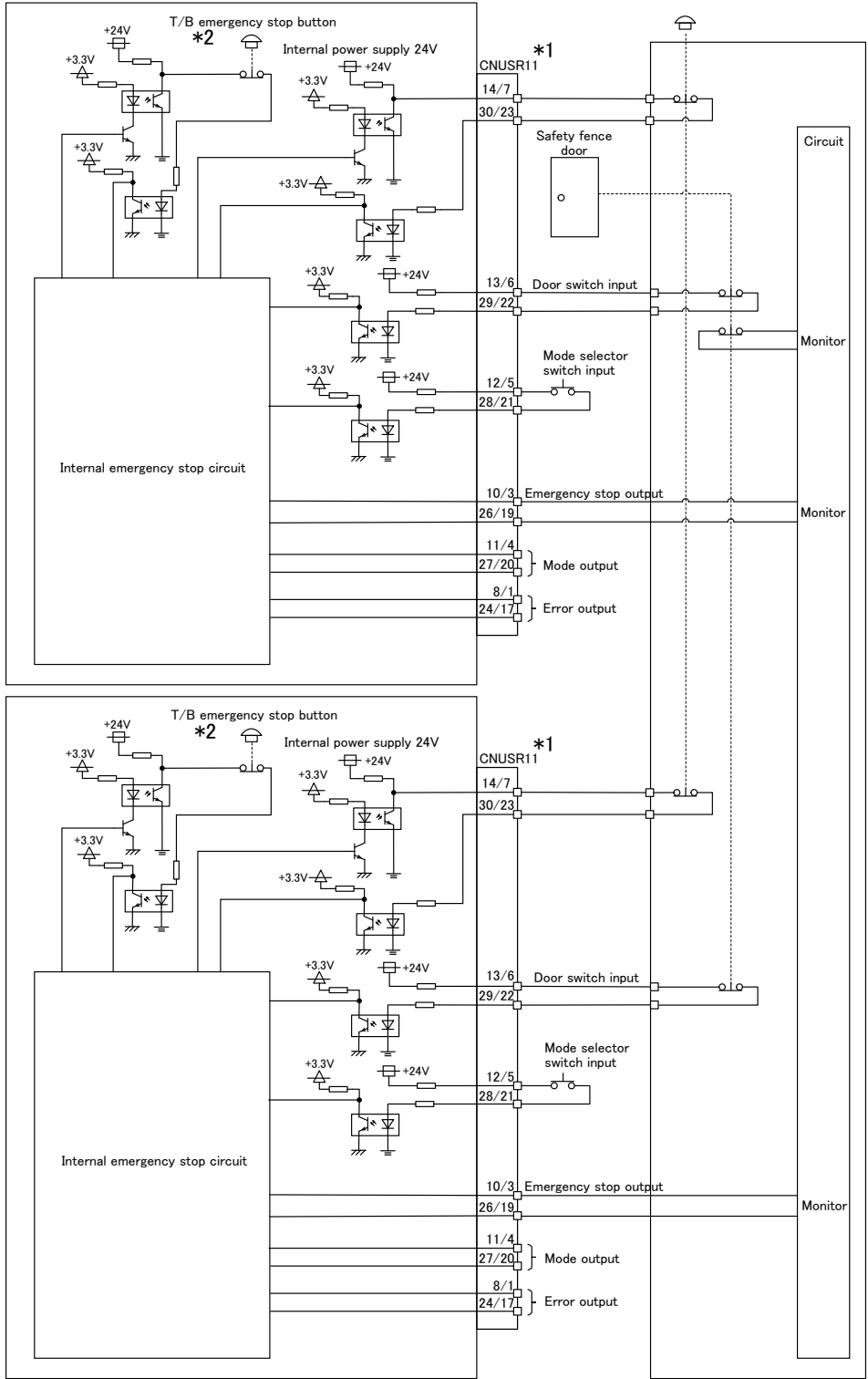

\*1) The CNUSR11 connector is a two-level terminal block, indicating that there are two circuits (channels). Two terminals (cable insertion holes) need to be used for one circuit.

\*2) The T/B emergency stop button connected with the controller.

Fig.6-3 : Example of safety measures (wiring example 3)

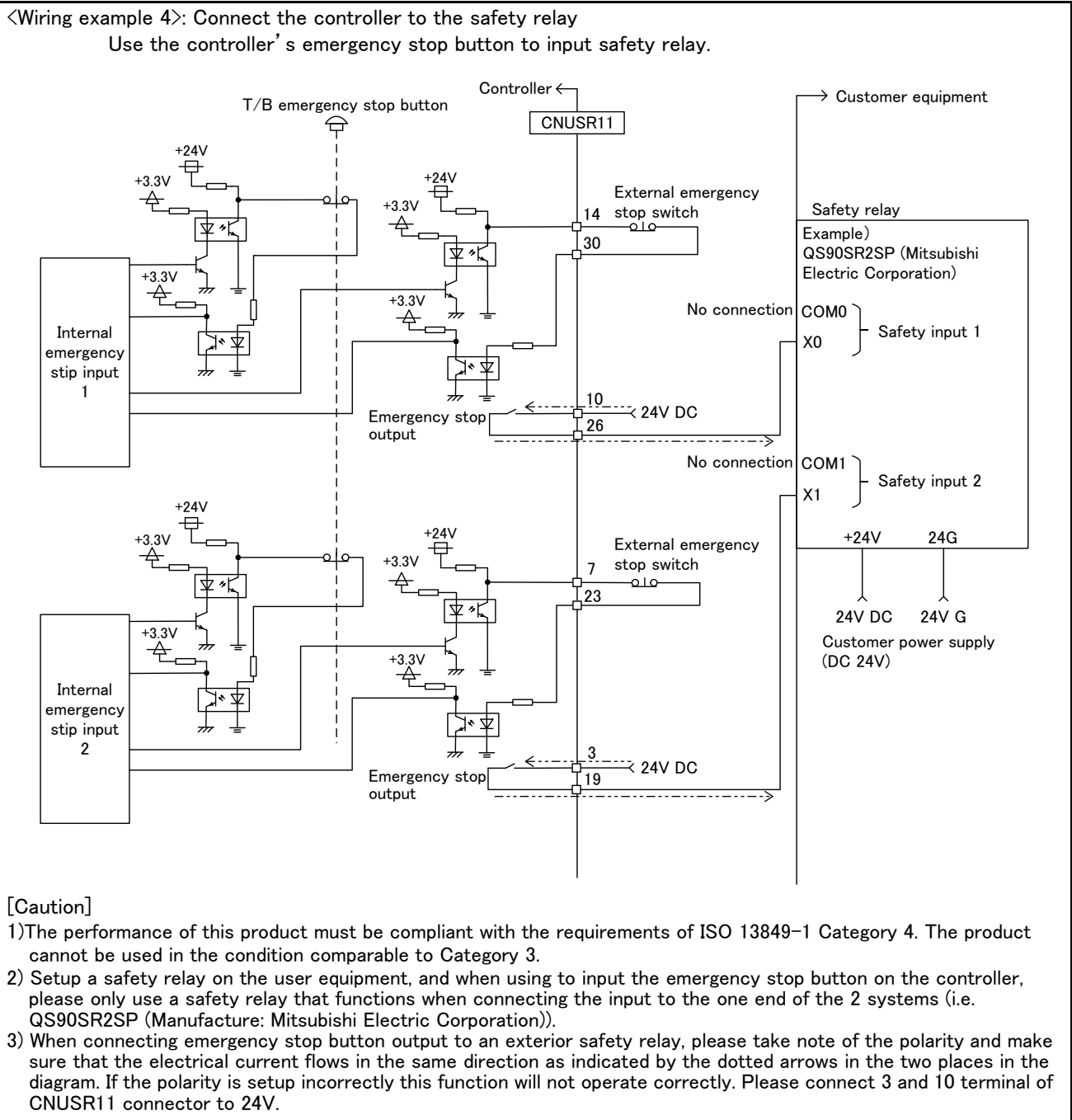

Fig.6-4 : Example of safety measures (wiring example 4)

## (1) External emergency stop connection [supplementary explanation]

- (1) Use a 2-contact type switch for all switches.
- (2) Install a limit switch on the safety fence's door. With a constantly open contact (normal open), wire to the door switch input terminal so that the switch turns ON (is conducted) when the door is closed, and turns OFF (is opened) when the door is open.
- (3) Use a manual-return type of normal close which have two lines for the emergency stop button.
- (4) Classify the faults into minor faults (faults that are easily restored and that do not have a great effect) and major faults (faults that cause the entire system to stop immediately, and that require care in restoration), and wire accordingly.

[Caution] The emergency stop input (terminal block) on the user wiring in the controller can be used for safety measures as shown in figure above. Note that there are limits to the No. of switch contacts, capacity and cable length, so refer to the following and install.

- Switch contact.....Prepare a 2-contact type.<sup>\*1)</sup>
- Switch contact capacityRelated current of 24 VDC or higher for a no-voltage contact. <sup>\*1)</sup>
- Cable length.....The length of the wire between the switch and terminal block must be max. 15m or less. Please use the shield line, in case of the cable may receive the noise etc. by other equipment, such as servo amplifier. And, if it is necessary, please fix a ferrite core (recommended model name: E04SR301334, manufacturer: Seiwa Electric Mfg. Co., Ltd.) to the shielded cable.

The size of the wire that fits to use is shown below.

CNUSR11 connector: AWG24 to 16 (0.2 to 1.25mm<sup>2</sup>)

Electric specification of the emergency stop related output circuit is 100mA/24V or less. Don't connect the equipment except for this range.

 **CAUTION**

Be sure to perform wiring correctly. If there are mistakes in the wiring, the robot may not stop when the emergency stop button is pressed and there will be a risk of damage or personal injury occurring.

After wiring, be sure to press each of the installed emergency stop switches and check whether the emergency stop circuit works properly.

 **CAUTION**

Be sure to duplicate connection of the emergency stop, door switch and mode selector switch. If not duplicated, these functions may fail due to a broken relay used by customer, etc.

---

\*1) The minimum load electric current of the switch is more than 5mA/24V.

## 6.2 Working environment

Avoid installation in the following places as the equipment's life and operation will be affected by the ambient environment conditions. When using in the following conditions, the customer must pay special attention to the preventive measures.

### (1) Power supply

- Where the voltage fluctuation will exceed the input voltage range.
- Where a momentary power failure exceeding 20ms may occur.
- Where the power capacity cannot be sufficiently secured.

### CAUTION

Please use the controller with an input power supply voltage fluctuation rate of 10% or less. In the case of 200 VAC input, for example, if the controller is used with 180 VAC during the day and 220 VAC during the night, turn the servo off once and then on again. If this is not performed, an excessive regeneration or overvoltage error may occur.

### (2) Noise

- Where a surge voltage exceeding 2000V, 5kHz (equivalent to EN61000-4-4) may be applied on the primary voltage. Near large inverters, high output frequency oscillator, large contactors and welding machines. Static noise may enter the lines when this product is used near radios or televisions. Keep the robot away from these items.

### (3) Temperature and humidity

- Where the atmospheric temperature exceeds 40 degree , lower than 0 degree.
- Where the relative humidity exceeds 85%RH, lower than 45%RH, and where dew may condense.
- Where the robot will be subject to direct sunlight or near heat generating sources such as heaters.

### (4) Vibration

- Where excessive vibration or impact may be applied. (Use in an environment of 34m/s<sup>2</sup> or less during transportation and 5m/s<sup>2</sup> or less during operation.)

### (5) Installation environment

- Where strong electric fields or magnetic fields are generated.
- Where the installation surface is rough. (Avoid installing the robot on a bumpy or inclined floor.)
- Where there is heavy powder dust and oil mist present.

## 6.3 Precautions for handling

(1) Robot has brakes on axis as shown below. The precision of the robot may drop, looseness may occur and the

Model	Axis
RV-2FR/2FRL	J2, J3, and J5 axes
RV-2FRB/2FRLB	All axes
RV-4FR/7FR/13FR series	All axes

reduction gears may be damaged if the robot is moved with force with the brakes applied. Moreover, when the axis without the brake is servo-off, take care to falling by the self-weight.

- (2) Avoid moving the robot arm by hand. When unavoidable, gradually move the arm. If moved suddenly, the accuracy may drop due to an excessive backlash, or the backed up data may be destroyed.
- (3) Note that depending on the posture, even when within the movement range, the wrist section could interfere with the base section. Take care to prevent interference during jog. <sup>\*1)</sup>
- (4) The robot arm consists of precision parts such as bearing. Lubricants such as grease are also applied on the moving parts to keep the mechanical accuracy. In a cold start under low temperature or in the first start after being stored for one month or longer, lubricants may not be spread enough. Such condition may lower the positioning accuracy, cause servo and overload alarms, and early wearing of the moving parts. To avoid such situation, perform warm-up operation of the machine at a low speed (at about 20% of normal operation speed).

\*1) Jog operation refers to operating the robot manually using the teaching pendant.

Move the robot arm from the lower to the upper limit of the movable range with the 30 degree joint angle or more for about 10 minutes. After that, speed up the operation gradually.

Please use the warm-up operation. (About the details of the warm-up operation, refer to "INSTRUCTION MANUAL/Detailed explanations of functions and operations".)

- (5) The robot arm and controller must be grounded with  $100\Omega$  or less (class D grounding) to secure the noise resistance and to prevent electric shocks.
- (6) The items described in these specifications are conditions for carrying out the periodic maintenance and inspections described in the instruction manual.
- (7) When using the robot arm on a mobile axis or elevating table, the machine cables enclosed as standard configuration may break due to the fixed installation specifications. In this case, use the "machine cable (replacement) for flexed" options.
- (8) If this robot interferes with the workpiece or peripheral devices during operation, the position may deviate, etc. Take care to prevent interference with the workpiece or peripheral devices during operation.
- (9) The hanging installation jig can be borrowed from the maker. Order to dealer when need.
- (10) Do not attach a tape or a label to the robot arm and the controller. If a tape or a label with strong adhesive power, such as a packaging tape, is attached to the coated surfaces of the robot arm and controller, the coated surface may be damaged when such tape or label is peeled off.
- (11) If the robot is operated with a heavy load and at a high speed, the surface of the robot arm gets very hot. It would not result in burns, however, it may cause secondary accidents if touched carelessly.
- (12) Do not shut down the input power supply to stop the robot. If the power supply is frequently shut down during a heavy load or high-speed operation, the speed reducer may be damaged, backlash may occur, and the program data may be destroyed.
- (13) If the J1, J2 and J3 axes collide with the mechanical stopper during the automatic operation of the robot, it is necessary to replace the resin part of the mechanical stopper unit. For the replacement of the resin parts, please contact Mitsubishi or Mitsubishi's dealer.  
If the resin part is not replaced, the mechanism unit and the speed reducer may be damaged significantly when the axes collide with the mechanical stopper next or subsequent time.
- (14) During the robot's automatic operation, a break is applied to the robot arm when the input power supply is shut down by a power failure, for instance. When a break is applied, the arm may deviate from the operation path predetermined by automatic operation and, as a result, it may interfere with the mechanical stopper depending on the operation at shutdown. In such a case, take an appropriate measure in advance to prevent any dangerous situation from occurring due to the interference between the arm and peripheral devices.  
Example) Installing a UPS (uninterruptible power supply unit) to the primary power source in order to reduce interference.
- (15) The J1 to J3 axes of the RV-13FR series generate loud noise during high-speed operation because of their reduction gear structure, but it does not affect the robot's function, performance, and a life.
- (16) Do not conduct an insulated voltage test. If conducted by mistake, it may result in a breakdown.
- (17) When the sequencer system becomes large too much, the robot's locus may deteriorate uncommonly. If this phenomenon occurs, inform to the dealer. And, when it turns out that the system is enlarged in advance, please inform our company.
- (18) Fretting may occur on the axis which moving angle or moving distance move minutely, or not moves. Fretting is that the required oil film becomes hard to be formed if the moving angle is small, and wear occurs. The axis which not moved is moving slightly by vibration etc. To make no fretting recommends to move these axes about once every day the 30 degree or more, or the 20mm or more.
- (19) The United Nations' Recommendations on the Transport of Dangerous Goods must be observed for trans-border transportation of lithium batteries by air, sea, and land. The lithium batteries (MR-BAT6V1, Q6BAT) used in Mitsubishi industrial robots contain lithium and fall under the definition.  
When the lithium batteries are shipped for storage, etc., they will be classified as Class 9: Miscellaneous dangerous substances and articles. Please contact your transportation company and must provide appropriate transport safety measures as the customer's consignor.
- (20) If the air supply temperature (primary piping) used for the tool etc. is lower than ambient air temperature, the dew condensation may occur on the coupling or the hose surface.
- (21) When fumigants that contain halogen materials such as fluorine, chlorine, bromine, and iodine are used for disinfecting and protecting wooden packaging from insects, they cause malfunction when entering our products. Please take necessary precautions to ensure that remaining materials from fumigant do not enter our products, or treat packaging with methods other than fumigation (heat method). Additionally, disinfect and protect wood from insects before packing products.

## 7 Appendix

### Appendix 1 : Inertia calculation method

An allowable moment of inertia in the mechanical interface at the tip of the robot arm is determined. If a load exceeding the allowable moment of inertia is put, on the tip of the arm, vibration during operation and an overload alarm may occur. Therefore, consider the matching/appropriateness of the hand and load to be mounted on the tip of the arm for the robot specifications when you select a robot. The following describes the load inertia calculation method.

For the vertical multi-joint robot, consider the load moment and the load inertia on the wrist axes (J4 to J6 axes). To consider them, calculate the load moment and load inertia applied on each of J4 to J6 axes in consideration of the posture of the hand and workpiece. The following figures show the examples.

#### (1) Load moment calculation example (for J5 axis with flange facing downwards)

The items shown in the right picture are defined as follows.

Hand mass :  $W_1$  (kg)

Center of gravity of the hand :  $L_1$  (m)

Workpiece mass :  $W_2$  (kg)

Center of gravity of the workpiece :  $L_2$  (m)

The load moment applied to the J5 axis is calculated as follows.

Where  $g$  is gravitational acceleration ( $m/s^2$ ).

$$\begin{aligned} \text{Load moment about the J5 axis : } M \text{ (Nm)} \\ = W_1 \times L_1 \times g + W_2 \times L_2 \times g \end{aligned}$$

Check that the value of  $M$  is equal to or less than the allowable load moment of the target model.

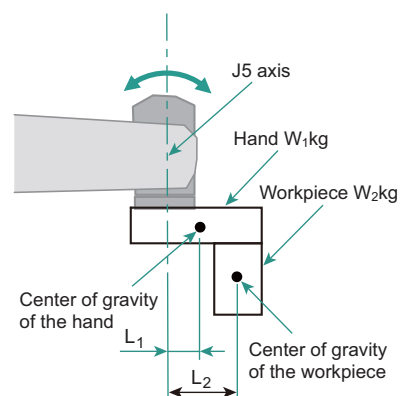

#### (2) Load inertia calculation example (for J6 axis)

The items shown in the right picture are defined as follows.

Hand mass :  $W_1$  (kg)

Distance between the center of J6 axis and the center of gravity of the hand :  $L_1$  (m)

Workpiece mass :  $W_2$  (kg)

Center of gravity of the workpiece :  $L_2$  (m)

Assume that both hand and workpiece are rectangle. When their surface areas can be expressed as follows, respectively:  $a_1 \times b_1$ , and  $a_2 \times b_2$  (where  $a$  = height,  $b$  = width), the load inertia about the J6 axis is calculated as follows.

$$\begin{aligned} \text{Load inertia about the J6 axis of the hand : } I_1 \text{ (kg}\cdot\text{m}^2) \\ = I_{z1} + W_1 \times L_1^2 = W_1 \times (a_1^2 + b_1^2)/12 + W_1 \times L_1^2 \end{aligned}$$

$$\begin{aligned} \text{Load inertia about the J6 axis of the workpiece : } I_2 \text{ (kg}\cdot\text{m}^2) \\ = I_{z2} + W_2 \times L_2^2 = W_2 \times (a_2^2 + b_2^2)/12 + W_2 \times L_2^2 \end{aligned}$$

$$\text{Total load inertia about the J6 axis of both hand and workpiece : } I \text{ (kg}\cdot\text{m}^2) = I_1 + I_2$$

Check that the value of  $I$  is equal to or less than the allowable load moment of the target model.

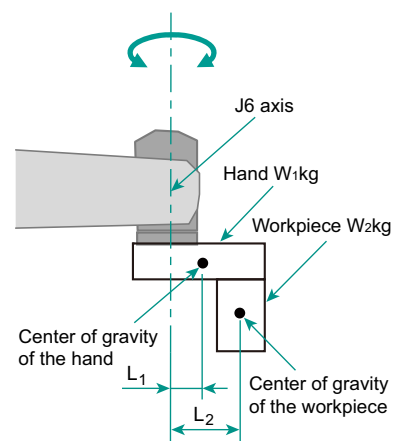

Note) When the robot changes its posture significantly in a direction other than the vertical downward direction, check the load moment inertia about the J4 axis as well.

Appendix 2 : Safety block diagram

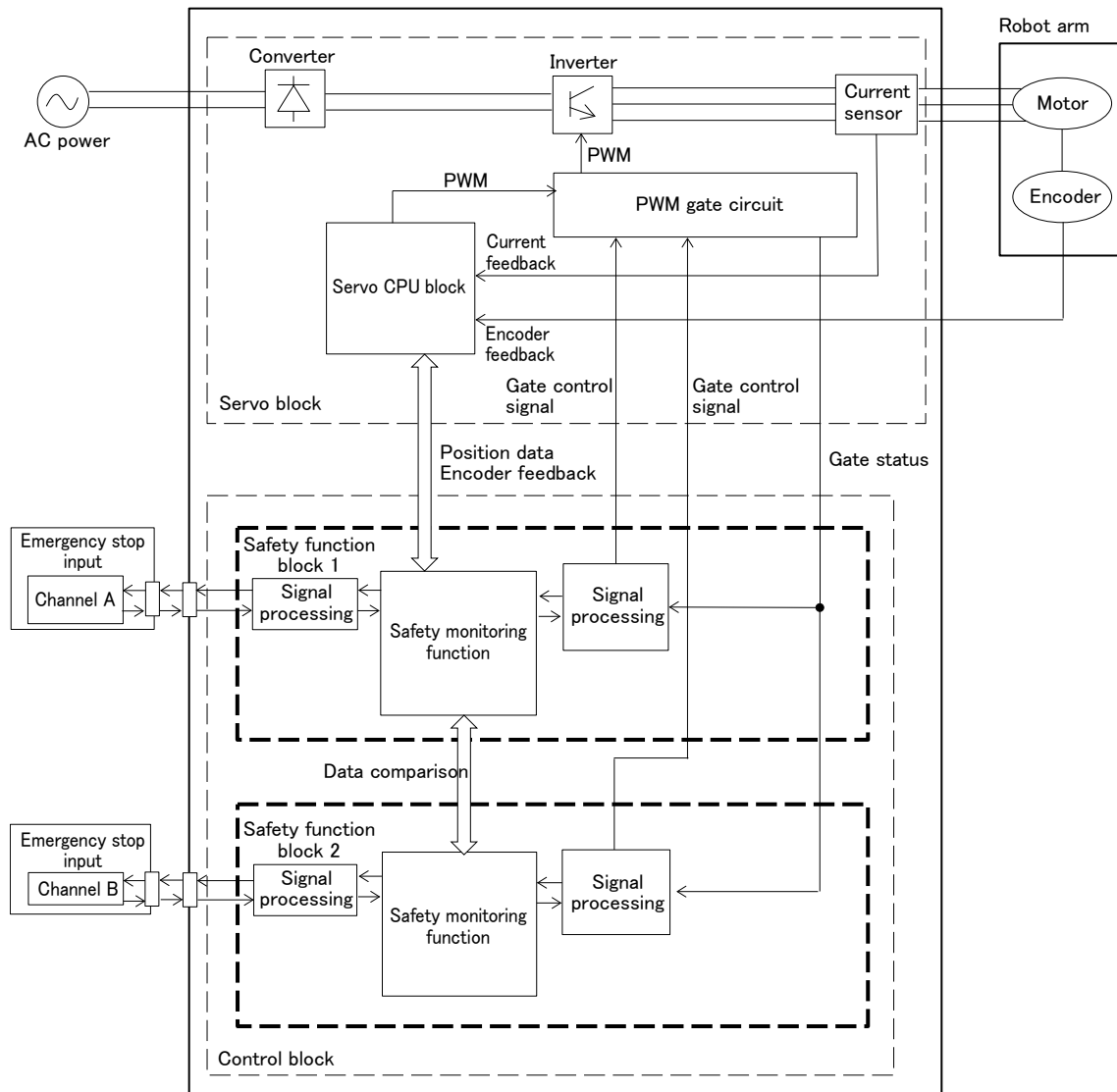

Fig.7-1 : Safety block diagram

Appendix 3 : Specifications discussion material (RV-2FR series)

Customer information

Company name		Name	
Address		Telephone	

Purchased model

Item	Type <sup>Note1)</sup>				Controller
Standard specification	<input type="checkbox"/> RV-2FR-D	<input type="checkbox"/> RV-2FRL-D	<input type="checkbox"/> RV-2FRB-D	<input type="checkbox"/> RV-2FRLB-D	CR800-02VD
	<input type="checkbox"/> RV-2FR-R	<input type="checkbox"/> RV-2FRL-R	<input type="checkbox"/> RV-2FRB-R	<input type="checkbox"/> RV-2FRLB-R	CR800-02VR
	<input type="checkbox"/> RV-2FR-Q	<input type="checkbox"/> RV-2FRL-Q	<input type="checkbox"/> RV-2FRB-Q	<input type="checkbox"/> RV-2FRLB-Q	CR800-02VQ

Note1) Refer to the Page 2, "1.2 Model type name of robot" for the details of the robot arm type name.

Shipping special specifications

Item	Standard specification	Special shipping specifications
Controller	Robot CPU unit connecting cable <input type="checkbox"/> 10m	<input type="checkbox"/> Not provided <input type="checkbox"/> 5m <input type="checkbox"/> 20m <input type="checkbox"/> 30m

Options (Installable after shipment)

Item	Type	Provision, and specifications when provided.	
Robot arm	Stopper for changing the operating range	1S-DH-11J1 <input type="checkbox"/> Not provided <input type="checkbox"/> Provided 1S-DH-11J2 <input type="checkbox"/> Not provided <input type="checkbox"/> Provided 1S-DH-11J3 <input type="checkbox"/> Not provided <input type="checkbox"/> Provided	
	Machine cable (replacement)	1F- <input type="checkbox"/> <input type="checkbox"/> UCBL-41 Fixed type: <input type="checkbox"/> Not provide <input type="checkbox"/> 2m <input type="checkbox"/> 10m <input type="checkbox"/> 15m <input type="checkbox"/> 20m	
		1F- <input type="checkbox"/> <input type="checkbox"/> LUCBL-41 Flexed type: <input type="checkbox"/> Not provide <input type="checkbox"/> 10m <input type="checkbox"/> 15m <input type="checkbox"/> 20m	
	Solenoid valve set	1E-VD0 <input type="checkbox"/> 1E-VD0 <input type="checkbox"/> E <input type="checkbox"/> Not provide 1E-VD0 <input type="checkbox"/> (Sink type): <input type="checkbox"/> 1set <input type="checkbox"/> 2set 1E-VD0 <input type="checkbox"/> E (Source type): <input type="checkbox"/> 1set <input type="checkbox"/> 2set	
	Hand input cable	1S-HC30C-11 <input type="checkbox"/> Not provided <input type="checkbox"/> Provided	
	Hand output cable	1E-GR35S <input type="checkbox"/> Not provided <input type="checkbox"/> Provided	
	Hand curl tube	1E-ST040 <input type="checkbox"/> C <input type="checkbox"/> Not provided <input type="checkbox"/> 1set <input type="checkbox"/> 2set	
Controller	Simple teaching pendant	R32TB- <input type="checkbox"/> <input type="checkbox"/> <input type="checkbox"/> Not provided <input type="checkbox"/> 7m <input type="checkbox"/> 15m	
	Highly efficient teaching pendant	R56TB- <input type="checkbox"/> <input type="checkbox"/> <input type="checkbox"/> Not provided <input type="checkbox"/> 7m <input type="checkbox"/> 15m	
	Parallel I/O interface	2D-TZ368/ 2D-TZ378 <input type="checkbox"/> Not provided 2D-TZ368(Sink type)/ <input type="checkbox"/> -1pc. <input type="checkbox"/> -2pc. 2D-TZ378(Source type)/ <input type="checkbox"/> -1pc. <input type="checkbox"/> -2pc.	
	External I/O cable (For parallel I/O interface)	2D-CBL <input type="checkbox"/> <input type="checkbox"/> <input type="checkbox"/> Not provided <input type="checkbox"/> 5m-( )pc. <input type="checkbox"/> 15m-( )pc.	
	Parallel I/O unit	2A-RZ361/ 2A-RZ371 <input type="checkbox"/> Not provided <input type="checkbox"/> 2A-RZ361(Sink type)/( ) unit <input type="checkbox"/> 2A-RZ371(Source type)/( ) unit	
	External I/O cable (For Parallel I/O unit)	2A-CBL <input type="checkbox"/> <input type="checkbox"/> <input type="checkbox"/> Not provided <input type="checkbox"/> 5m-( )pc. <input type="checkbox"/> 15m-( )pc.	
	CC-Link interface	2D-TZ576 <input type="checkbox"/> Not provided <input type="checkbox"/> Provided	
	EtherNet/IP interface	2D-TZ535 <input type="checkbox"/> Not provided <input type="checkbox"/> Provided	
	PROFINET interface	2D-TZ535-PN <input type="checkbox"/> Not provided <input type="checkbox"/> Provided	
	CC-Link IE Field interface	2F-DQ535 <input type="checkbox"/> Not provided <input type="checkbox"/> Provided	
	EtherCAT interface	2F-DQ535-EC <input type="checkbox"/> Not provided <input type="checkbox"/> Provided	
	Function extension card	2F-DQ510	MELFA Smart Plus card pack (A-type): <input type="checkbox"/> Not provided <input type="checkbox"/> Provided
		2F-DQ520	MELFA Smart Plus card pack (AB-type): <input type="checkbox"/> Not provided <input type="checkbox"/> Provided
		2F-DQ511	MELFA Smart Plus card (A-type): <input type="checkbox"/> Not provided <input type="checkbox"/> Provided
		2F-DQ521	MELFA Smart Plus card (B-type): <input type="checkbox"/> Not provided <input type="checkbox"/> Provided
	SD memory card	2F-2GBSD <input type="checkbox"/> Not provided <input type="checkbox"/> Provided	
	Safety option	4F-SF002-01 <input type="checkbox"/> Not provided <input type="checkbox"/> Provided	
Controller protection box	CR800-MB <input type="checkbox"/> Not provided <input type="checkbox"/> Provided		
RT ToolBox3	3F-14C-WINE <input type="checkbox"/> Not provided <input type="checkbox"/> Windows XP/Vista/7/8/8.1/10 English CD-ROM		
RT ToolBox3 mini	3F-15C-WINE <input type="checkbox"/> Not provided <input type="checkbox"/> Windows XP/Vista/7/8/8.1/10 English CD-ROM		
RT ToolBox3 Pro	3F-16D-WINE <input type="checkbox"/> Not provided <input type="checkbox"/> Windows XP/Vista/7/8/8.1/10 English DVD-ROM		
Instructions manual	5F-GA01-PE01 <input type="checkbox"/> Not provided <input type="checkbox"/> Provided ( ) sets		
Function extension	Force sensor set	4F-FS002H-W200 <input type="checkbox"/> Not provided <input type="checkbox"/> Provided	
		4F-FS002H-W1000 <input type="checkbox"/> Not provided <input type="checkbox"/> Provided	
	MELFA-3D Vision	4F-3DVS2-PKG3 <input type="checkbox"/> Not provided <input type="checkbox"/> Provided	

Maintenance parts (Consumable parts)

Maintenance parts	<input type="checkbox"/> Backup batteries MR-BAT6V1 ( ) pcs. <input type="checkbox"/> Backup batteries Q6BAT <sup>Note1)</sup> ( ) pcs. <input type="checkbox"/> Grease ( ) cans
-------------------	--

Note1) Only the CR800-Q controller is applicable.

Robot selection check list

Work description	<input type="checkbox"/> Material handling <input type="checkbox"/> Assembly <input type="checkbox"/> Machining L/UL <input type="checkbox"/> Sealing <input type="checkbox"/> Testing and inspection <input type="checkbox"/> Other ( )		
Workpiece mass ( ) g	Hand mass ( ) g	Atmosphere <input type="checkbox"/> General environment <input type="checkbox"/> Other ( )	
Remarks			



## Appendix 4 : Specifications discussion material (RV-4FR/7FR series)

## ■ Customer information

Company name		Name	
Address		Telephone	

## ■ Purchased model

Type <sup>Note1)</sup>					Controller <sup>Note2)</sup>
<input type="checkbox"/> RV-4FR-D	<input type="checkbox"/> RV-4FRL-D	<input type="checkbox"/> RV-4FRJL-D	<input type="checkbox"/> RV-7FR-D	<input type="checkbox"/> RV-7FRL-D	CR800-0*VD
<input type="checkbox"/> RV-4FR-R	<input type="checkbox"/> RV-4FRL-R	<input type="checkbox"/> RV-4FRJL-R	<input type="checkbox"/> RV-7FR-R	<input type="checkbox"/> RV-7FRL-R	CR800-0*VR
<input type="checkbox"/> RV-4FR-Q	<input type="checkbox"/> RV-4FRL-Q	<input type="checkbox"/> RV-4FRJL-Q	<input type="checkbox"/> RV-7FR-Q	<input type="checkbox"/> RV-7FRL-Q	CR800-0*VQ

Note1) Refer to the Page 2, "1.2 Model type name of robot" for the details of the robot arm type name.

Note2) "\*" in the controller shows the maximum load of the robot arm. (4kg: "4", 7kg: "7")

## ■ Shipping special specifications

Item	Standard specifications	Shipping special specifications
Robot arm	Oil mist specification (IP67)	General environment specification (IP40) <input type="checkbox"/> Not provided <input type="checkbox"/> Provided
	Clean specification (ISO class3)	General environment specification (IP40) <input type="checkbox"/> Not provided <input type="checkbox"/> Provided
	Internal wiring and piping specification <sup>Note1)</sup>	Equipped to the forearm <input type="checkbox"/> Not provided <input type="checkbox"/> -SH01 <input type="checkbox"/> -SH02 <input type="checkbox"/> -SH03 <input type="checkbox"/> -SH04 <input type="checkbox"/> -SH05
Controller	Robot CPU unit connecting cable <input type="checkbox"/> 10m	<input type="checkbox"/> Not provided <input type="checkbox"/> 5m <input type="checkbox"/> 20m <input type="checkbox"/> 30m

Note1) The corresponding base external wiring set is attached.

## ■ Options (Installable after shipment)

Item	Type	Provision, and specifications when provided.
Robot arm	J1 axis operating range change	1F-DH-03 For RV-4FR series: <input type="checkbox"/> Not provided <input type="checkbox"/> Provided 1F-DH-04 For RV-7FR series: <input type="checkbox"/> Not provided <input type="checkbox"/> Provided
	Machine cable (replacement)	1F- <input type="checkbox"/> <input type="checkbox"/> UCBL-41 Fixed type: <input type="checkbox"/> Not provide <input type="checkbox"/> 2m <input type="checkbox"/> 10m <input type="checkbox"/> 15m <input type="checkbox"/> 20m
		1F- <input type="checkbox"/> <input type="checkbox"/> LUCBL-41 Flexed type: <input type="checkbox"/> Not provide <input type="checkbox"/> 10m <input type="checkbox"/> 15m <input type="checkbox"/> 20m
	Solenoid valve set	1F-VD0 <input type="checkbox"/> -02 <input type="checkbox"/> Not provide
		1F-VD0 <input type="checkbox"/> E-02 1F-VD0 <input type="checkbox"/> -02 (Sink type): <input type="checkbox"/> 1set <input type="checkbox"/> 2set <input type="checkbox"/> 3set <input type="checkbox"/> 4set 1F-VD0 <input type="checkbox"/> E-02 (Source type): <input type="checkbox"/> 1set <input type="checkbox"/> 2set <input type="checkbox"/> 3set <input type="checkbox"/> 4set
	Hand input cable	1F-HC35S-02 <input type="checkbox"/> Not provided <input type="checkbox"/> Provided
	Hand output cable	1F-GR35S-02 <input type="checkbox"/> Not provided <input type="checkbox"/> Provided
	Hand curl tube	1E-ST040 <input type="checkbox"/> C <input type="checkbox"/> Not provided <input type="checkbox"/> 1set <input type="checkbox"/> 2set <input type="checkbox"/> 3set <input type="checkbox"/> 4set
Forearm external wiring set	1F-HB0 <input type="checkbox"/> S-01 <input type="checkbox"/> Not provided <input type="checkbox"/> 1F-HB01S-01 <input type="checkbox"/> 1F-HB02S-01	
Base external wiring set	1F-HA0 <input type="checkbox"/> S-01 <input type="checkbox"/> Not provided <input type="checkbox"/> 1F-HA01S-01 <input type="checkbox"/> 1F-HA02S-01	
Controller	Simple teaching pendant	R32TB- <input type="checkbox"/> <input type="checkbox"/> <input type="checkbox"/> Not provided <input type="checkbox"/> 7m <input type="checkbox"/> 15m
	Highly efficient teaching pendant	R56TB- <input type="checkbox"/> <input type="checkbox"/> <input type="checkbox"/> Not provided <input type="checkbox"/> 7m <input type="checkbox"/> 15m
	Parallel I/O interface	2D-TZ368/ 2D-TZ378 <input type="checkbox"/> Not provided 2D-TZ368(Sink type)/ <input type="checkbox"/> -1pc. <input type="checkbox"/> -2pc. 2D-TZ378(Source type)/ <input type="checkbox"/> -1pc. <input type="checkbox"/> -2pc.
	External I/O cable (For parallel I/O interface)	2D-CBL <input type="checkbox"/> <input type="checkbox"/> <input type="checkbox"/> Not provided <input type="checkbox"/> 5m-( )pc. <input type="checkbox"/> 15m-( )pc.
		2A-RZ361/ 2A-RZ371 <input type="checkbox"/> Not provided <input type="checkbox"/> 2A-RZ361(Sink type)/( ) unit <input type="checkbox"/> 2A-RZ371(Source type)/( ) unit
	Parallel I/O unit	2A-RZ361/ 2A-RZ371 <input type="checkbox"/> Not provided <input type="checkbox"/> 5m-( )pc. <input type="checkbox"/> 15m-( )pc.
		2A-CBL <input type="checkbox"/> <input type="checkbox"/> <input type="checkbox"/> Not provided <input type="checkbox"/> 5m-( )pc. <input type="checkbox"/> 15m-( )pc.
	CC-Link interface	2D-TZ576 <input type="checkbox"/> Not provided <input type="checkbox"/> Provided
	EtherNet/IP interface	2D-TZ535 <input type="checkbox"/> Not provided <input type="checkbox"/> Provided
	PROFINET interface	2D-TZ535-PN <input type="checkbox"/> Not provided <input type="checkbox"/> Provided
	CC-Link IE Field interface	2F-DQ535 <input type="checkbox"/> Not provided <input type="checkbox"/> Provided
	EtherCAT interface	2F-DQ535-EC <input type="checkbox"/> Not provided <input type="checkbox"/> Provided
	Function extension card	2F-DQ510 MELFA Smart Plus card pack (A-type): <input type="checkbox"/> Not provided <input type="checkbox"/> Provided
		2F-DQ520 MELFA Smart Plus card pack (AB-type): <input type="checkbox"/> Not provided <input type="checkbox"/> Provided
		2F-DQ511 MELFA Smart Plus card (A-type): <input type="checkbox"/> Not provided <input type="checkbox"/> Provided
		2F-DQ521 MELFA Smart Plus card (B-type): <input type="checkbox"/> Not provided <input type="checkbox"/> Provided
	SD memory card	2F-2GBSD <input type="checkbox"/> Not provided <input type="checkbox"/> Provided
	Safety option	4F-SF002-01 <input type="checkbox"/> Not provided <input type="checkbox"/> Provided
	Controller protection box	CR800-MB <input type="checkbox"/> Not provided <input type="checkbox"/> Provided
	RT ToolBox3	3F-14C-WINE <input type="checkbox"/> Not provided <input type="checkbox"/> Windows XP/Vista/7/8/8.1/10 English CD-ROM
RT ToolBox3 mini	3F-15C-WINE <input type="checkbox"/> Not provided <input type="checkbox"/> Windows XP/Vista/7/8/8.1/10 English CD-ROM	
RT ToolBox3 Pro	3F-16D-WINE <input type="checkbox"/> Not provided <input type="checkbox"/> Windows XP/Vista/7/8/8.1/10 English DVD-ROM	
Instructions manual	5F-GA01-PE01 <input type="checkbox"/> Not provided <input type="checkbox"/> Provided ( ) sets	
Function extension	Force sensor set	4F-FS002-W200 <input type="checkbox"/> Not provided <input type="checkbox"/> Provided 4F-FS002-W1000 <input type="checkbox"/> Not provided <input type="checkbox"/> Provided
	MELFA-3D Vision	4F-3DVS2-PKG3 <input type="checkbox"/> Not provided <input type="checkbox"/> Provided

## ■ Maintenance parts (Consumable parts)

Maintenance parts	<input type="checkbox"/> Backup batteries MR-BAT6V1 ( ) pcs. <input type="checkbox"/> Backup batteries Q6BAT <sup>Note1)</sup> ( ) pcs. <input type="checkbox"/> Grease ( ) cans
-------------------	--

Note1) Only the CR800-Q controller is applicable.

## ■ Robot selection check list

Work description	<input type="checkbox"/> Material handling <input type="checkbox"/> Assembly <input type="checkbox"/> Machining L/UL <input type="checkbox"/> Sealing <input type="checkbox"/> Testing and inspection <input type="checkbox"/> Other ( )		
Workpiece mass ( )g	Hand mass ( )g	Atmosphere <input type="checkbox"/> General environment <input type="checkbox"/> Clean <input type="checkbox"/> Oil mist: Confirm oil proof <input type="checkbox"/> request (Oil name: )/ <input type="checkbox"/> not request <sup>Note1)</sup> <input type="checkbox"/> Other ( )	
Remarks			

Note1) Refer to Page 37, "2.2.6 Protection specifications" about oil resistance.

## Appendix 5 : Specifications discussion material (RV-7FRL)

## ■ Customer information

Company name		Name	
Address		Telephone	

## ■ Purchased model

Type <sup>Note1)</sup>	Controller
<input type="checkbox"/> RV-7FRL-D	CR800-07VLD
<input type="checkbox"/> RV-7FRL-R	CR800-07VLR
<input type="checkbox"/> RV-7FRL-Q	CR800-07VLQ

Note1) Refer to the [Page 2, "1.2 Model type name of robot"](#) for the details of the robot arm type name.

## ■ Shipping special specifications

Item	Standard specifications	Shipping special specifications
Robot arm	Oil mist specification (IP67)	General environment specification (IP40) <input type="checkbox"/> Not provided <input type="checkbox"/> Provided
	Clean specification (ISO class3)	General environment specification (IP40) <input type="checkbox"/> Not provided <input type="checkbox"/> Provided
	Internal wiring and piping specification <sup>Note1)</sup>	Equipped to the forearm <input type="checkbox"/> Not provided <input type="checkbox"/> -SH01 <input type="checkbox"/> -SH02 <input type="checkbox"/> -SH03 <input type="checkbox"/> -SH04 <input type="checkbox"/> -SH05
Controller	Robot CPU unit connecting cable <input type="checkbox"/> 10m	<input type="checkbox"/> Not provided <input type="checkbox"/> 5m <input type="checkbox"/> 20m <input type="checkbox"/> 30m

Note1) The corresponding base external wiring set is attached.

## ■ Options (Installable after shipment)

Item	Type	Provision, and specifications when provided.	
Robot arm	J1 axis operating range change	1F-DH-05J1 <input type="checkbox"/> Not provided <input type="checkbox"/> Provided	
	Machine cable (replacement)	1F- <input type="checkbox"/> UCBL-41	Fixed type: <input type="checkbox"/> Not provide <input type="checkbox"/> 2m <input type="checkbox"/> 10m <input type="checkbox"/> 15m <input type="checkbox"/> 20m
		1F- <input type="checkbox"/> LUCBL-41	Flexed type: <input type="checkbox"/> Not provide <input type="checkbox"/> 10m <input type="checkbox"/> 15m <input type="checkbox"/> 20m
	Solenoid valve set	1F-VD0 <input type="checkbox"/> -02 1F-VD0 <input type="checkbox"/> E-02	<input type="checkbox"/> Not provide 1F-VD0 <input type="checkbox"/> -02 (Sink type): <input type="checkbox"/> 1set <input type="checkbox"/> 2set <input type="checkbox"/> 3set <input type="checkbox"/> 4set 1F-VD0 <input type="checkbox"/> E-02 (Source type): <input type="checkbox"/> 1set <input type="checkbox"/> 2set <input type="checkbox"/> 3set <input type="checkbox"/> 4set
	Hand input cable	1F-HC35S-02	<input type="checkbox"/> Not provided <input type="checkbox"/> Provided
	Hand output cable	1F-GR35S-02	<input type="checkbox"/> Not provided <input type="checkbox"/> Provided
	Hand curl tube	1E-ST040 <input type="checkbox"/> C	<input type="checkbox"/> Not provided <input type="checkbox"/> 1set <input type="checkbox"/> 2set <input type="checkbox"/> 3set <input type="checkbox"/> 4set
	Forearm external wiring set	1F-HB0 <input type="checkbox"/> S-01	<input type="checkbox"/> Not provided <input type="checkbox"/> 1F-HB01S-01 <input type="checkbox"/> 1F-HB02S-01
Base external wiring set	1F-HA0 <input type="checkbox"/> S-01	<input type="checkbox"/> Not provided <input type="checkbox"/> 1F-HA01S-01 <input type="checkbox"/> 1F-HA02S-01	
Controller	Simple teaching pendant	R32TB- <input type="checkbox"/> <input type="checkbox"/>	<input type="checkbox"/> Not provided <input type="checkbox"/> 7m <input type="checkbox"/> 15m
	Highly efficient teaching pendant	R56TB- <input type="checkbox"/> <input type="checkbox"/>	<input type="checkbox"/> Not provided <input type="checkbox"/> 7m <input type="checkbox"/> 15m
	Parallel I/O interface	2D-TZ368/ 2D-TZ378	<input type="checkbox"/> Not provided 2D-TZ368(Sink type)/ <input type="checkbox"/> -1pc. <input type="checkbox"/> -2pc. 2D-TZ378(Source type)/ <input type="checkbox"/> -1pc. <input type="checkbox"/> -2pc.
	External I/O cable (For parallel I/O interface)	2D-CBL <input type="checkbox"/> <input type="checkbox"/> (2D-TZ368/TZ378)	<input type="checkbox"/> Not provided <input type="checkbox"/> 5m-( )pc. <input type="checkbox"/> 15m-( )pc.
	Parallel I/O unit	2A-RZ361/ 2A-RZ371	<input type="checkbox"/> Not provided <input type="checkbox"/> 2A-RZ361(Sink type)/( ) unit <input type="checkbox"/> 2A-RZ371(Source type)/( ) unit
	External I/O cable (For Parallel I/O unit)	2A-CBL <input type="checkbox"/> <input type="checkbox"/> (2A-RZ361/RZ371)	<input type="checkbox"/> Not provided <input type="checkbox"/> 5m-( )pc. <input type="checkbox"/> 15m-( )pc.
	CC-Link interface	2D-TZ576	<input type="checkbox"/> Not provided <input type="checkbox"/> Provided
	EtherNet/IP interface	2D-TZ535	<input type="checkbox"/> Not provided <input type="checkbox"/> Provided
	PROFINET interface	2D-TZ535-PN	<input type="checkbox"/> Not provided <input type="checkbox"/> Provided
	CC-Link IE Field interface	2F-DQ535	<input type="checkbox"/> Not provided <input type="checkbox"/> Provided
	EtherCAT interface	2F-DQ535-EC	<input type="checkbox"/> Not provided <input type="checkbox"/> Provided
	Function extension card	2F-DQ510	MELFA Smart Plus card pack (A-type): <input type="checkbox"/> Not provided <input type="checkbox"/> Provided
		2F-DQ520	MELFA Smart Plus card pack (AB-type): <input type="checkbox"/> Not provided <input type="checkbox"/> Provided
		2F-DQ511	MELFA Smart Plus card (A-type): <input type="checkbox"/> Not provided <input type="checkbox"/> Provided
		2F-DQ521	MELFA Smart Plus card (B-type): <input type="checkbox"/> Not provided <input type="checkbox"/> Provided
	SD memory card	2F-2GBSD	<input type="checkbox"/> Not provided <input type="checkbox"/> Provided
	Safety option	4F-SF002-01	<input type="checkbox"/> Not provided <input type="checkbox"/> Provided
Controller protection box	CR800-MB	<input type="checkbox"/> Not provided <input type="checkbox"/> Provided	
RT ToolBox3	3F-14C-WINE	<input type="checkbox"/> Not provided <input type="checkbox"/> Windows XP/Vista/7/8/8.1/10 English CD-ROM	
RT ToolBox3 mini	3F-15C-WINE	<input type="checkbox"/> Not provided <input type="checkbox"/> Windows XP/Vista/7/8/8.1/10 English CD-ROM	
RT ToolBox3 Pro	3F-16D-WINE	<input type="checkbox"/> Not provided <input type="checkbox"/> Windows XP/Vista/7/8/8.1/10 English DVD-ROM	
Instructions manual	5F-GA01-PE01	<input type="checkbox"/> Not provided <input type="checkbox"/> Provided ( ) sets	
Function extension	Force sensor set	4F-FS002-W200	<input type="checkbox"/> Not provided <input type="checkbox"/> Provided
		4F-FS002-W1000	<input type="checkbox"/> Not provided <input type="checkbox"/> Provided
	MELFA-3D Vision	4F-3DVS2-PKG3	<input type="checkbox"/> Not provided <input type="checkbox"/> Provided

## ■ Maintenance parts (Consumable parts)

Maintenance parts	<input type="checkbox"/> Backup batteries MR-BAT6V1 ( ) pcs. <input type="checkbox"/> Backup batteries Q6BAT <sup>Note1)</sup> ( ) pcs. <input type="checkbox"/> Grease ( ) cans
-------------------	--

Note1) Only the CR800-Q controller is applicable.

## ■ Robot selection check list

Work description	<input type="checkbox"/> Material handling <input type="checkbox"/> Assembly <input type="checkbox"/> Machining L/UL <input type="checkbox"/> Sealing <input type="checkbox"/> Testing and inspection <input type="checkbox"/> Other ( )		
Workpiece mass ( ) g	Hand mass ( ) g	Atmosphere	<input type="checkbox"/> General environment <input type="checkbox"/> Clean <input type="checkbox"/> Oil mist: Confirm oil proof <input type="checkbox"/> request (Oil name: )/ <input type="checkbox"/> not request <sup>Note1)</sup> <input type="checkbox"/> Other ( )
Remarks			

Note1) Refer to [Page 37, "2.2.6 Protection specifications"](#) about oil resistance.

Appendix 6 : Specifications discussion material (RV-13FR/13FRL)

Customer information

Company name		Name	
Address		Telephone	

Purchased model

Type <sup>Note1)</sup>		Controller
<input type="checkbox"/> RV-13FR-D	<input type="checkbox"/> RV-13FRL-D	CR800-13VD
<input type="checkbox"/> RV-13FR-R	<input type="checkbox"/> RV-13FRL-R	CR800-13VR
<input type="checkbox"/> RV-13FR-Q	<input type="checkbox"/> RV-13FRL-Q	CR800-13VQ

Note1) Refer to the Page 2, "1.2 Model type name of robot" for the details of the robot arm type name.

Shipping special specifications

Item	Standard specifications	Shipping special specifications
Robot arm	Oil mist specification (IP67)	General environment specification (IP40) <input type="checkbox"/> Not provided <input type="checkbox"/> Provided
	Clean specification (ISO class3)	General environment specification (IP40) <input type="checkbox"/> Not provided <input type="checkbox"/> Provided
	Internal wiring and piping specification <sup>Note1)</sup>	Equipped to the forearm <input type="checkbox"/> Not provided <input type="checkbox"/> -SH01 <input type="checkbox"/> -SH02 <input type="checkbox"/> -SH03 <input type="checkbox"/> -SH04 <input type="checkbox"/> -SH05
Controller	Robot CPU unit connecting cable <input type="checkbox"/> 10m	<input type="checkbox"/> Not provided <input type="checkbox"/> 5m <input type="checkbox"/> 20m <input type="checkbox"/> 30m

Note1) The corresponding base external wiring set is attached.

Options (Installable after shipment)

Item	Type	Provision, and specifications when provided.	
Robot arm	J1 axis operating range change	1F-DH-05J1 <input type="checkbox"/> Not provided <input type="checkbox"/> Provided	
	Machine cable (replacement)	1F- <input type="checkbox"/> <input type="checkbox"/> UCBL-41	Fixed type: <input type="checkbox"/> Not provide <input type="checkbox"/> 2m <input type="checkbox"/> 10m <input type="checkbox"/> 15m <input type="checkbox"/> 20m
		1F- <input type="checkbox"/> <input type="checkbox"/> LUCBL-41	Flexed type: <input type="checkbox"/> Not provide <input type="checkbox"/> 10m <input type="checkbox"/> 15m <input type="checkbox"/> 20m
	Solenoid valve set	1F-VD0 <input type="checkbox"/> -03 1F-VD0 <input type="checkbox"/> E-03 <input type="checkbox"/> Not provide 1F-VD0 <input type="checkbox"/> -03 (Sink type): <input type="checkbox"/> 1set <input type="checkbox"/> 2set <input type="checkbox"/> 3set <input type="checkbox"/> 4set 1F-VD0 <input type="checkbox"/> E-03 (Source type): <input type="checkbox"/> 1set <input type="checkbox"/> 2set <input type="checkbox"/> 3set <input type="checkbox"/> 4set	
	Hand input cable	1F-HC35S-02 <input type="checkbox"/> Not provided <input type="checkbox"/> Provided	
	Hand output cable	1F-GR35S-02 <input type="checkbox"/> Not provided <input type="checkbox"/> Provided	
	Hand curl tube	1N-ST060 <input type="checkbox"/> C <input type="checkbox"/> Not provided <input type="checkbox"/> 1set <input type="checkbox"/> 2set <input type="checkbox"/> 3set <input type="checkbox"/> 4set	
	Forearm external wiring set	1F-HB0 <input type="checkbox"/> S-01 <input type="checkbox"/> Not provided <input type="checkbox"/> 1F-HB01S-01 <input type="checkbox"/> 1F-HB02S-01	
Base external wiring set	1F-HA0 <input type="checkbox"/> S-01 <input type="checkbox"/> Not provided <input type="checkbox"/> 1F-HA01S-01 <input type="checkbox"/> 1F-HA02S-01		
Controller	Simple teaching pendant	R32TB- <input type="checkbox"/> <input type="checkbox"/> <input type="checkbox"/> Not provided <input type="checkbox"/> 7m <input type="checkbox"/> 15m	
	Highly efficient teaching pendant	R56TB- <input type="checkbox"/> <input type="checkbox"/> <input type="checkbox"/> Not provided <input type="checkbox"/> 7m <input type="checkbox"/> 15m	
	Parallel I/O interface	2D-TZ368/ 2D-TZ378 <input type="checkbox"/> Not provided 2D-TZ368(Sink type)/ <input type="checkbox"/> -1pc. <input type="checkbox"/> -2pc. 2D-TZ378(Source type)/ <input type="checkbox"/> -1pc. <input type="checkbox"/> -2pc.	
	External I/O cable (For parallel I/O interface)	2D-CBL <input type="checkbox"/> <input type="checkbox"/> (2D-TZ368/TZ378) <input type="checkbox"/> Not provided <input type="checkbox"/> 5m-( )pc. <input type="checkbox"/> 15m-( )pc.	
	Parallel I/O unit	2A-RZ361/ 2A-RZ371 <input type="checkbox"/> Not provided <input type="checkbox"/> 2A-RZ361(Sink type)/( ) unit <input type="checkbox"/> 2A-RZ371(Source type)/( ) unit	
	External I/O cable (For Parallel I/O unit)	2A-CBL <input type="checkbox"/> <input type="checkbox"/> (2A-RZ361/RZ371) <input type="checkbox"/> Not provided <input type="checkbox"/> 5m-( )pc. <input type="checkbox"/> 15m-( )pc.	
	CC-Link interface	2D-TZ576 <input type="checkbox"/> Not provided <input type="checkbox"/> Provided	
	CC-Link interface	2D-TZ576 <input type="checkbox"/> Not provided <input type="checkbox"/> Provided	
	EtherNet/IP interface	2D-TZ535 <input type="checkbox"/> Not provided <input type="checkbox"/> Provided	
	PROFINET interface	2D-TZ535-PN <input type="checkbox"/> Not provided <input type="checkbox"/> Provided	
	CC-Link IE Field interface	2F-DQ535 <input type="checkbox"/> Not provided <input type="checkbox"/> Provided	
	EtherCAT interface	2F-DQ535-EC <input type="checkbox"/> Not provided <input type="checkbox"/> Provided	
	Function extension card	2F-DQ510	MELFA Smart Plus card pack (A-type): <input type="checkbox"/> Not provided <input type="checkbox"/> Provided
		2F-DQ520	MELFA Smart Plus card pack (AB-type): <input type="checkbox"/> Not provided <input type="checkbox"/> Provided
		2F-DQ511	MELFA Smart Plus card (A-type): <input type="checkbox"/> Not provided <input type="checkbox"/> Provided
		2F-DQ521	MELFA Smart Plus card (B-type): <input type="checkbox"/> Not provided <input type="checkbox"/> Provided
	SD memory card	2F-2GBSD <input type="checkbox"/> Not provided <input type="checkbox"/> Provided	
	Safety option	4F-SF002-01 <input type="checkbox"/> Not provided <input type="checkbox"/> Provided	
	Controller protection box	CR800-MB <input type="checkbox"/> Not provided <input type="checkbox"/> Provided	
	RT ToolBox3	3F-14C-WINE <input type="checkbox"/> Not provided <input type="checkbox"/> Windows XP/Vista/7/8/8.1/10 English CD-ROM	
	RT ToolBox3 mini	3F-15C-WINE <input type="checkbox"/> Not provided <input type="checkbox"/> Windows XP/Vista/7/8/8.1/10 English CD-ROM	
	RT ToolBox3 Pro	3F-16D-WINE <input type="checkbox"/> Not provided <input type="checkbox"/> Windows XP/Vista/7/8/8.1/10 English DVD-ROM	
	Instructions manual	5F-GA01-PE01 <input type="checkbox"/> Not provided <input type="checkbox"/> Provided ( ) sets	
Function extension	Force sensor set	4F-FS002-W200 <input type="checkbox"/> Not provided <input type="checkbox"/> Provided	
		4F-FS002-W1000 <input type="checkbox"/> Not provided <input type="checkbox"/> Provided	
	MELFA-3D Vision	4F-3DVS2-PKG3 <input type="checkbox"/> Not provided <input type="checkbox"/> Provided	

Maintenance parts (Consumable parts)

Maintenance parts	<input type="checkbox"/> Backup batteries MR-BAT6V1 ( ) pcs. <input type="checkbox"/> Backup batteries Q6BAT <sup>Note1)</sup> ( ) pcs. <input type="checkbox"/> Grease ( ) cans
-------------------	--

Note1) Only the CR800-Q controller is applicable.

Robot selection check list

Work description	<input type="checkbox"/> Material handling <input type="checkbox"/> Assembly <input type="checkbox"/> Machining L/UL <input type="checkbox"/> Sealing <input type="checkbox"/> Testing and inspection <input type="checkbox"/> Other ( )		
Workpiece mass ( ) g	Hand mass ( ) g	Atmosphere <input type="checkbox"/> General environment <input type="checkbox"/> Clean <input type="checkbox"/> Oil mist: Confirm oil proof <input type="checkbox"/> request (Oil name: ) / <input type="checkbox"/> not request <sup>Note1)</sup> <input type="checkbox"/> Other ( )	
Remarks			

Note1) Refer to Page 37, "2.2.6 Protection specifications" about oil resistance.

Appendix 7 : Specifications discussion material (RV-20FR)

■ Customer information

Company name		Name	
Address		Telephone	

■ Purchased model

Type <sup>Note1)</sup>	Controller
<input type="checkbox"/> RV-20FR-D	CR800-20VD
<input type="checkbox"/> RV-20FR-R	CR800-20VR
<input type="checkbox"/> RV-20FR-Q	CR800-20VQ

Note1) Refer to the Page 2, "1.2 Model type name of robot" for the details of the robot arm type name.

■ Shipping special specifications

Item	Standard specifications	Shipping special specifications
Robot arm	Oil mist specification (IP67)	General environment specification (IP40) <input type="checkbox"/> Not provided <input type="checkbox"/> Provided
	Clean specification (ISO class3)	General environment specification (IP40) <input type="checkbox"/> Not provided <input type="checkbox"/> Provided
	Internal wiring and piping specification <sup>Note1)</sup>	Equipped to the forearm <input type="checkbox"/> Not provided <input type="checkbox"/> -SH01 <input type="checkbox"/> -SH02 <input type="checkbox"/> -SH03 <input type="checkbox"/> -SH04 <input type="checkbox"/> -SH05
Controller	Robot CPU unit connecting cable <input type="checkbox"/> 10m	<input type="checkbox"/> Not provided <input type="checkbox"/> 5m <input type="checkbox"/> 20m <input type="checkbox"/> 30m

Note1) The corresponding base external wiring set is attached.

■ Options (Installable after shipment)

Item	Type	Provision, and specifications when provided.	
Robot arm	J1 axis operating range change	1F-DH-05J1 <input type="checkbox"/> Not provided <input type="checkbox"/> Provided	
	Machine cable (replacement)	1F- <input type="checkbox"/> UCBL-41	Fixed type: <input type="checkbox"/> Not provide <input type="checkbox"/> 2m <input type="checkbox"/> 10m <input type="checkbox"/> 15m <input type="checkbox"/> 20m
		1F- <input type="checkbox"/> LUCBL-41	Flexed type: <input type="checkbox"/> Not provide <input type="checkbox"/> 10m <input type="checkbox"/> 15m <input type="checkbox"/> 20m
	Solenoid valve set	1F-VD0 <input type="checkbox"/> -03 1F-VD0 <input type="checkbox"/> E-03	<input type="checkbox"/> Not provide 1F-VD0 <input type="checkbox"/> -03 (Sink type): <input type="checkbox"/> 1set <input type="checkbox"/> 2set <input type="checkbox"/> 3set <input type="checkbox"/> 4set 1F-VD0 <input type="checkbox"/> E-03 (Source type): <input type="checkbox"/> 1set <input type="checkbox"/> 2set <input type="checkbox"/> 3set <input type="checkbox"/> 4set
	Hand input cable	1F-HC35S-02	<input type="checkbox"/> Not provided <input type="checkbox"/> Provided
	Hand output cable	1F-GR35S-02	<input type="checkbox"/> Not provided <input type="checkbox"/> Provided
	Hand curl tube	1N-ST060 <input type="checkbox"/> C	<input type="checkbox"/> Not provided <input type="checkbox"/> 1set <input type="checkbox"/> 2set <input type="checkbox"/> 3set <input type="checkbox"/> 4set
	Forearm external wiring set	1F-HB0 <input type="checkbox"/> S-01	<input type="checkbox"/> Not provided <input type="checkbox"/> 1F-HB01S-01 <input type="checkbox"/> 1F-HB02S-01
	Base external wiring set	1F-HA0 <input type="checkbox"/> S-01	<input type="checkbox"/> Not provided <input type="checkbox"/> 1F-HA01S-01 <input type="checkbox"/> 1F-HA02S-01
	Controller	Simple teaching pendant	R32TB- <input type="checkbox"/> <input type="checkbox"/>
Highly efficient teaching pendant		R56TB- <input type="checkbox"/> <input type="checkbox"/>	<input type="checkbox"/> Not provided <input type="checkbox"/> 7m <input type="checkbox"/> 15m
Parallel I/O interface		2D-TZ368/ 2D-TZ378	<input type="checkbox"/> Not provided 2D-TZ368(Sink type)/ <input type="checkbox"/> -1pc. <input type="checkbox"/> -2pc. 2D-TZ378(Source type)/ <input type="checkbox"/> -1pc. <input type="checkbox"/> -2pc.
External I/O cable (For parallel I/O interface)		2D-CBL <input type="checkbox"/> <input type="checkbox"/> (2D-TZ368/TZ378)	<input type="checkbox"/> Not provided <input type="checkbox"/> 5m-( )pc. <input type="checkbox"/> 15m-( )pc.
Parallel I/O unit		2A-RZ361/ 2A-RZ371	<input type="checkbox"/> Not provided <input type="checkbox"/> 2A-RZ361(Sink type)/( ) unit <input type="checkbox"/> 2A-RZ371(Source type)/( ) unit
External I/O cable (For Parallel I/O unit)		2A-CBL <input type="checkbox"/> <input type="checkbox"/> (2A-RZ361/RZ371)	<input type="checkbox"/> Not provided <input type="checkbox"/> 5m-( )pc. <input type="checkbox"/> 15m-( )pc.
CC-Link interface		2D-TZ576	<input type="checkbox"/> Not provided <input type="checkbox"/> Provided
EtherNet/IP interface		2D-TZ535	<input type="checkbox"/> Not provided <input type="checkbox"/> Provided
PROFINET interface		2D-TZ535-PN	<input type="checkbox"/> Not provided <input type="checkbox"/> Provided
CC-Link IE Field interface		2F-DQ535	<input type="checkbox"/> Not provided <input type="checkbox"/> Provided
EtherCAT interface		2F-DQ535-EC	<input type="checkbox"/> Not provided <input type="checkbox"/> Provided
Function extension card		2F-DQ510	MELFA Smart Plus card pack (A-type): <input type="checkbox"/> Not provided <input type="checkbox"/> Provided
		2F-DQ520	MELFA Smart Plus card pack (AB-type): <input type="checkbox"/> Not provided <input type="checkbox"/> Provided
		2F-DQ511	MELFA Smart Plus card (A-type): <input type="checkbox"/> Not provided <input type="checkbox"/> Provided
		2F-DQ521	MELFA Smart Plus card (B-type): <input type="checkbox"/> Not provided <input type="checkbox"/> Provided
SD memory card		2F-2GBSD	<input type="checkbox"/> Not provided <input type="checkbox"/> Provided
Safety option		4F-SF002-01	<input type="checkbox"/> Not provided <input type="checkbox"/> Provided
Controller protection box		CR800-MB	<input type="checkbox"/> Not provided <input type="checkbox"/> Provided
RT ToolBox3		3F-14C-WINE	<input type="checkbox"/> Not provided <input type="checkbox"/> Windows XP/Vista/7/8/8.1/10 English CD-ROM
RT ToolBox3 mini		3F-15C-WINE	<input type="checkbox"/> Not provided <input type="checkbox"/> Windows XP/Vista/7/8/8.1/10 English CD-ROM
RT ToolBox3 Pro	3F-16D-WINE	<input type="checkbox"/> Not provided <input type="checkbox"/> Windows XP/Vista/7/8/8.1/10 English DVD-ROM	
Instructions manual	5F-GA01-PE01	<input type="checkbox"/> Not provided <input type="checkbox"/> Provided ( ) sets	
Function extension	Force sensor set	4F-FS002-W200	<input type="checkbox"/> Not provided <input type="checkbox"/> Provided
		4F-FS002-W1000	<input type="checkbox"/> Not provided <input type="checkbox"/> Provided
	MELFA-3D Vision	4F-3DVS2-PKG3	<input type="checkbox"/> Not provided <input type="checkbox"/> Provided

■ Maintenance parts (Consumable parts)

Maintenance parts	<input type="checkbox"/> Backup batteries MR-BAT6V1 ( ) pcs. <input type="checkbox"/> Backup batteries Q6BAT <sup>Note1)</sup> ( ) pcs. <input type="checkbox"/> Grease ( ) cans
-------------------	--

Note1) Only the CR800-Q controller is applicable.

■ Robot selection check list

Work description	<input type="checkbox"/> Material handling <input type="checkbox"/> Assembly <input type="checkbox"/> Machining L/UL <input type="checkbox"/> Sealing <input type="checkbox"/> Testing and inspection <input type="checkbox"/> Other ( )		
Workpiece mass ( ) g	Hand mass ( ) g	Atmosphere <input type="checkbox"/> General environment <input type="checkbox"/> Clean	Confirm oil proof <input type="checkbox"/> request (Oil name: ) / <input type="checkbox"/> not request <sup>Note1)</sup> <input type="checkbox"/> Other ( )
		<input type="checkbox"/> Oil mist:	
Remarks			

Note1) Refer to Page 37, "2.2.6 Protection specifications" about oil resistance.



# **MITSUBISHI ELECTRIC CORPORATION**

HEAD OFFICE: TOKYO BUILDING, 2-7-3, MARUNOUCHI, CHIYODA-KU, TOKYO 100-8310, JAPAN  
NAGOYA WORKS: 5-1-14, YADA-MINAMI, HIGASHI-KU NAGOYA 461-8670, JAPAN

Authorised representative:

Mitsubishi Electric Europe B.V. FA - European Business Group  
Mitsubishi-Electric-Platz 1, D-40882 Ratingen, Germany  
Tel: +49(0)2102-4860